

TOSHIBA

UM-TS01***-E002

PROGRAMMABLE CONTROLLER

PROSEC **T1/T1S**

USER' S MANUAL

– Expansion I/O –

[Main Menu](#)
[Contents](#)

TOSHIBA CORPORATION

Important Information

Misuse of this equipment can result in property damage or human injury. Because controlled system applications vary widely, you should satisfy yourself as to the acceptability of this equipment for your intended purpose. In no event will Toshiba Corporation be responsible or liable for either indirect or consequential damage or injury that may result from the use of this equipment.

No patent liability is assumed by Toshiba Corporation with respect to use of information, illustrations, circuits, equipment or examples of application in this publication.

Toshiba Corporation reserves the right to make changes and improvements to this publication and/or related products at any time without notice. No obligation shall be incurred other than as noted in this publication.

This publication is copyrighted and contains proprietary material. No part of this book may be reproduced, stored in a retrieval system, or transmitted, in any form or by any means — electrical, mechanical, photocopying, recording, or otherwise — without obtaining prior written permission from Toshiba Corporation.

© TOSHIBA Corporation 1996. All rights reserved

PROSEC and TOSLINE are registered trademarks of TOSHIBA Corporation.

Publication number: UM-TS01***-E002
1st edition July 1996, 3rd edition Dec. 1998

Safety Precautions

This manual is prepared for users of Toshiba's Programmable Controller T1/T1S. Read this manual thoroughly before using the T1/T1S. Also, keep this manual and related manuals so that you can read them anytime while the T1/T1S is in operation.

Hazard Classifications

In the manuals related to the T1/T1S, the following two hazard classifications are used to explain the safety precautions.

 **WARNING** Indicates a potentially hazardous situation which, if not avoided, could result in death or serious injury.

 **CAUTION** Indicates a potentially hazardous situation which, if not avoided, may result in minor or moderate injury. It may also be used to alert against unsafe practices.

Even a precaution is classified as CAUTION, it may cause serious results depending on the situation. Observe all the safety precautions described on this manual.

Safety Precautions

CAUTION

- Turn off power to the T1/T1S before removing or mounting the option card or I/O module. Failure to do so can cause electrical shock or damage to the product.
- Read the Safety Precautions described in the "T1/T1S User's Manual – Basic Hardware and Function –" before using the option cards and the I/O modules.
- Follow the instructions described in this manual and in the "T1/T1S User's Manual – Basic Hardware and Function –" when installing and wiring the option cards or I/O modules.
- The option cards and I/O modules have been designed for the T1/T1S. Use your option cards or I/O modules only with the T1/T1S.
- Do not touch electronic components on the printed circuit board of the option cards or I/O modules. It may cause damage to the product.
- Use attached screw (puller) for removing the option card. Do not pull I/O cable for removing the option card. It can cause unsafe situation because of cable disconnection.

About This Manual

About This Manual

This manual explains the specifications and operations of the expansion I/Os (option cards, expansion units and T2 type I/O modules) which are used with the T1/T1S. The TOSLINE-F10 data link card is also covered in this manual. For your better understanding of the T1/T1S, read the following manual at first to understand the T1/T1S system, then read this manual.

T1/T1S User' s manual – Basic Hardware and Function – UM-TS01***-E001

Terminology

The following is a list of abbreviations and acronyms used in this manual.

μs	microsecond
ASCII	American Standard Code For Information Interchange
AWG	American Wire Gage
CPU	Central Processing Unit
CRC	Cyclic Redundancy Checking
EEPROM	Electrically Erasable Programmable Read Only Memory
H	hexadecimal (when it appears in front of an alphanumeric string)
I/O	Input/Output
LED	Light Emitting Diode
ms	millisecond
RAM	Random Access Memory
ROM	Read Only Memory
Vac	AC voltage
Vdc	DC voltage

Contents

Safety Precautions	1
About This Manual	2
1. System Configuration	5
1.1 T1/T1S system configuration	6
1.2 Using the option card	8
1.3 Using the expansion unit	9
1.4 Using the T2 I/O module	11
1.5 Power capacity consideration	13
1.6 Optional items	14
2. Specifications	15
2.1 Option card	16
2.2 Expansion unit	26
2.3 T2 I/O module	31
3. Installation	59
3.1 Mounting the option card	60
3.2 Connecting the expansion unit	62
3.3 Connecting the expansion rack	63
3.4 Mounting the I/O module	64
4. I/O Allocation	65
4.1 I/O allocation overview	66
4.2 I/O allocation methods	69
4.3 Register assignment	70
5. Supplement for TOSLINE-F10	79
5.1 Network configuration	80
5.2 Register assignment	81
5.3 RAS information	82

Section 1

System Configuration

- 1.1 T1/T1S system configuration, 6*
- 1.2 Using the option card, 8*
- 1.3 Using the expansion unit, 9*
- 1.4 Using the T2 I/O module, 11*
- 1.5 Power capacity consideration, 13*
- 1.6 Optional items, 14*

1. System Configuration

1.1 T1/T1S system configuration

The following figure shows the T1/T1S system configuration.

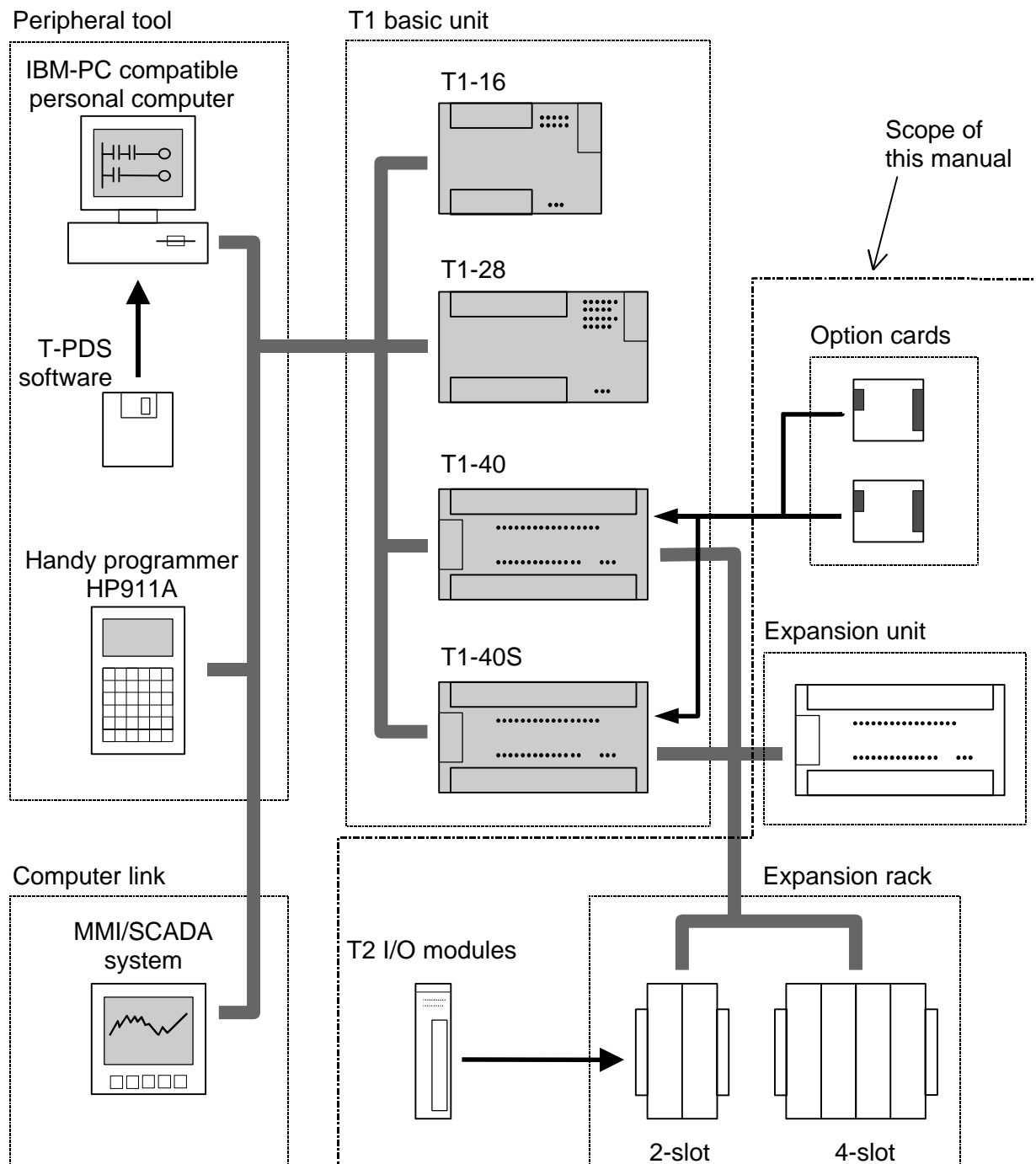

1. System Configuration

The T1-16 and the T1-28 are fixed I/O points controllers. The T1-40 and T1-40S, however, have I/O expandability. There are three ways to expand its I/O points. They are using the option card, using the expansion unit, and using the T2 type I/O module.

The option card is an I/O expansion card for the T1-40/T1-40S. It is approximately 1/2 the size of a credit card. The T1-40/T1-40S can hold up to two option cards.

The expansion unit is a fixed I/O points expansion unit. Its size is the same as the T1-40/T1-40S.

The T1-40/T1-40S can be connected to a 2-slot or 4-slot expansion rack allowing it to use most T2 I/O modules.

Either one expansion unit or one expansion rack can be connected with the T1-40/T1-40S. The option card can be used together with the expansion unit or the expansion rack.

This manual explains the specifications of the option cards, the expansion unit and the I/O modules, and how to use them with the T1-40/T1-40S.

Regarding the I/O expandability, there is no difference between the T1-40 and the T1-40S. Therefore, in this manual, T1-40 and T1-40S are called as T1-40(S) for ease of explanation.

1. System Configuration

1.2 Using the option card

The T1-40(S) has two slots for mounting the option cards on the right side of the unit. The following eight types of the option cards are available.

Type	Description	Power supply
DI116	16 points input, 24 Vdc - 5 mA	Supplied from the basic unit (5 Vdc). See section 1.5.
DO116	16 points output, 24 Vdc - 100 mA	
DD116	8 points input, 24 Vdc - 5 mA + 8 points output, 24 Vdc - 100 mA	
AD121	1 channel analog input 0-5V/0-20mA	
AD131	1 channel analog input $\pm 10V$	
DA121	1 channel analog output 0-20mA	
DA131	1 channel analog output $\pm 10V$	
FR112	TOSLINE-F10 remote station, 1 word input + 1 word output	

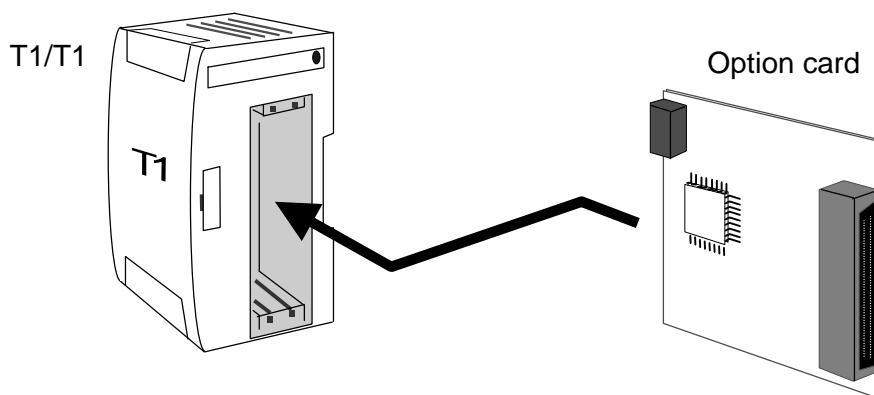

- Up to two option cards can be installed.
- The TOSLINE-F10 card (FR112) can be used together with other option card. However, two FR112s cannot be used at a time.
- Cable side connector for the discrete I/O card (DI116, DO116 or DD116) is not supplied with the option card. This connector is separately available. See section 1.6.
- A screw (puller) for removing the option card from the T1-40(S) is attached to the option card.

1. System Configuration

1.3 Using the expansion unit

The T1-40(S) has an expansion connector for connecting the expansion unit or the expansion rack on the right side of the unit.

The expansion unit has 32 points I/O (16 inputs and 16 outputs).

Two types of the expansion unit are available. They are T1-EDR32 (DC input type) and T1-EAR32 (AC input type).

Either one expansion unit can be connected to the T1-40(S).

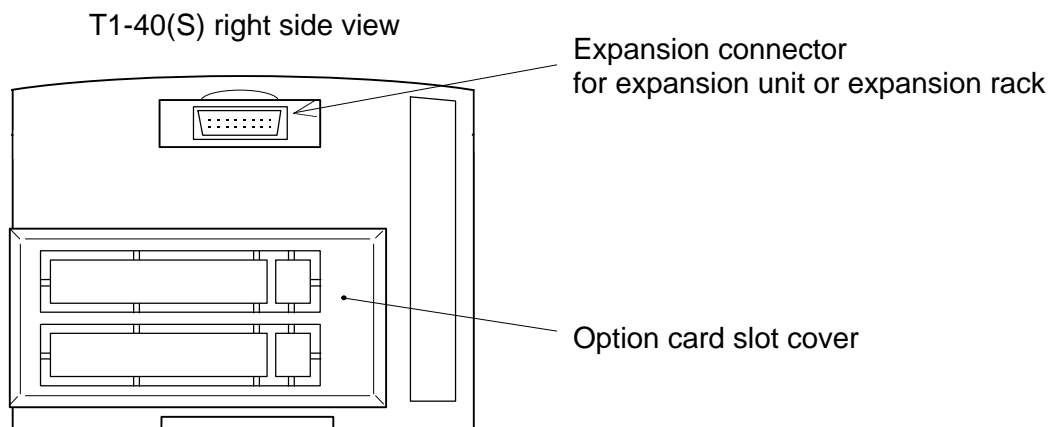

The following two types of the expansion unit are available.

Type	Description	Power supply
T1-EDR32	Input: 16 points, 24 Vdc - 7 mA	Supplied from the basic unit (5Vdc). See section 1.5.
	Output: 16 points, relay, 240 Vac/24 Vdc (max.) - 2 A/point (max.)	
T1-EAR32	Input: 16 points, 100 to 120 Vac - 7 mA	
	Output: 16 points, relay, 240 Vac/24 Vdc (max.) - 2 A/point (max.)	

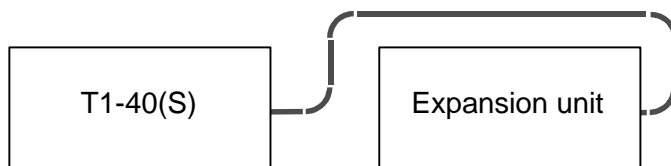

Note) Only one expansion unit can be connected.

1. System Configuration

External feature of the expansion unit

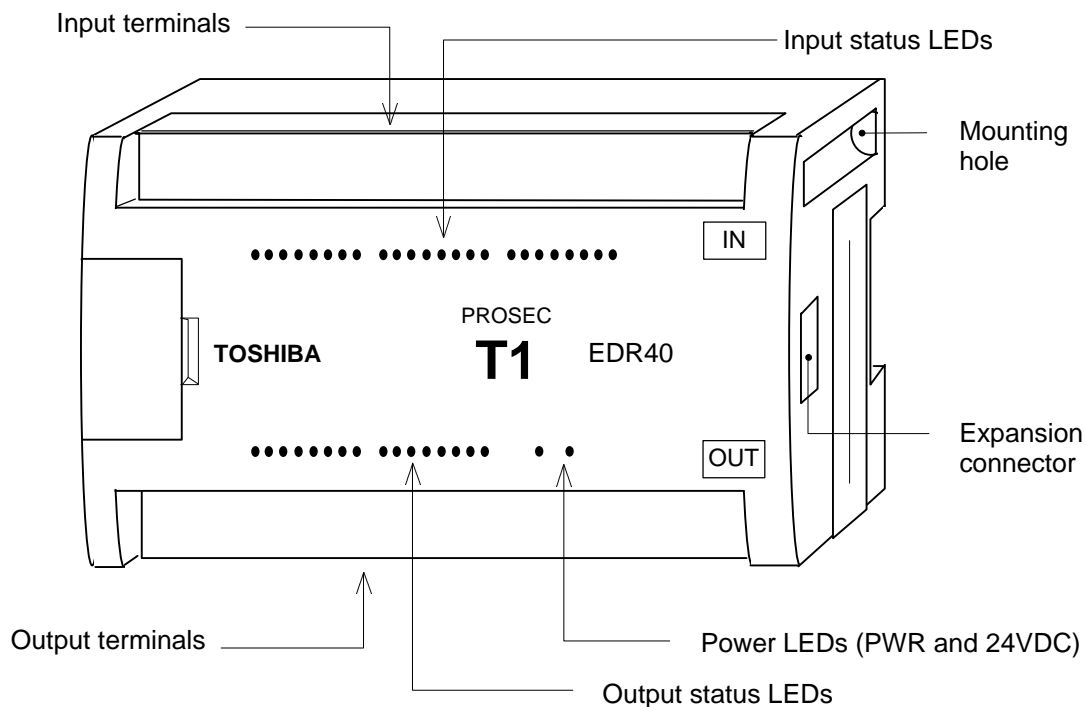

Status LEDs:

Name	Color	Function
PWR (Power)	Green	Lit when 5 Vdc supplied from the basic unit is normal.
24VDC	Green	Lit when external 24 Vdc for output relay coil is normal.
Input status LEDs	Red	Lit when the corresponding input signal is ON.
Output status LEDs	Red	Lit when the corresponding output signal is ON.

- Either one expansion unit or one expansion rack can be connected with the T1-40(S).
- A 0.5 m expansion cable is supplied with the expansion unit.
- Output relay coil power (24Vdc) is required on the expansion unit.
- DIN rail bracket is provided on the expansion rack.

1. System Configuration

1.4 Using the T2 I/O module

The T1-40(S) has an expansion connector for connecting the expansion unit or the expansion rack on the right side of the unit.

The expansion rack is used for connecting T2 I/O modules with the T1-40(S).

Two types of the expansion racks are available. They are 2-slot rack and 4-slot rack. Either one expansion rack can be connected to the T1-40(S). By using the expansion rack, the T1-40(S) can control up to 2 or up to 4 T2 I/O modules.

The following two types of the expansion racks are available.

Type	Description	Power supply
BU152	Two I/O modules can be mounted (2-slot rack)	Supplied from the basic unit (5 Vdc). See section 1.5.
BU154	Four I/O modules can be mounted (4-slot rack)	

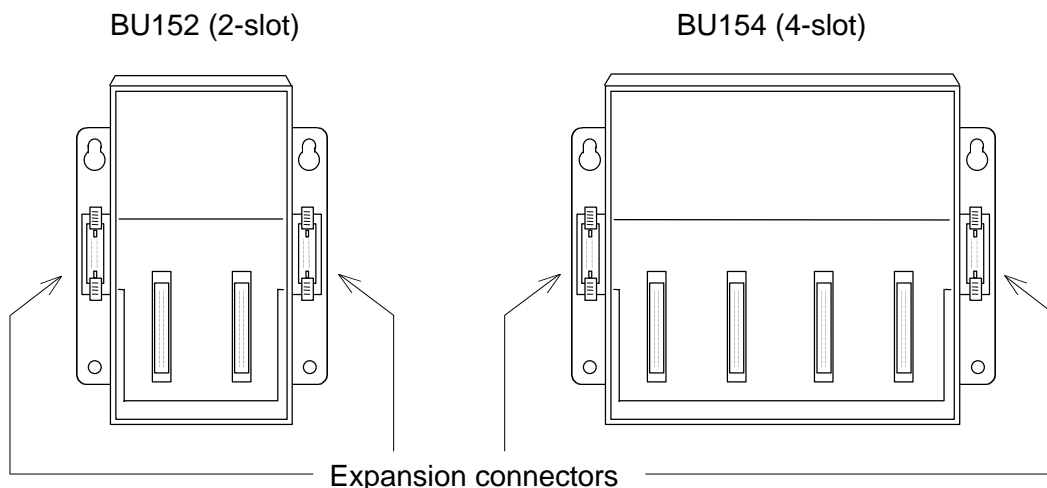

- Either one expansion unit or one expansion rack can be connected with the T1-40(S).
- A 0.2 m expansion cable is supplied with the expansion rack.
- No power supply module is required on the expansion rack.
- Expansion connectors are provided on the both sides. However either one can be used at a time.
- DIN rail bracket is not provided on the expansion rack.

1. System Configuration

The list below shows the I/O modules available for the T1-40(S).

Type	Name	Specifications
DI31	DC/AC input	16 points (16 points/common), 12 to 24 Vdc/Vac
DI32	DC input	32 points (4 × 8 points/common), 24 Vdc
DI235		64 points (8 × 8 points/common), 24 Vdc
IN51	AC input	16 points (16 points/common), 100 to 120 Vac
IN61		16 points (16 points/common), 200 to 240 Vac
RO61	Relay output	12 points (3 × 4 points/common), 240 Vac/24 Vdc (max.), 2 A/point, 4 A/common (max.)
RO62		8 points (isolated), 240 Vac/24 Vdc (max.), 2 A/point (max.)
RO263		16 points (2 × 8 points/common), 240 Vac/24 Vdc (max.), 2 A/point, 8 A/commom (max.)
DO31	Transistor output (current sink)	16 points (16 points/common), 5 to 24 Vdc, 1 A/point, 1.2 A/4 points (max.)
DO32		32 points (4 × 8 points/common), 5 to 24 Vdc, 0.1 A/point (max.)
DO235		64 points (8 × 8 points/common), 5 to 24 Vdc, 0.1 A/point (max.)
DO233P	Transistor output (current source)	16 points (16 points/common), 5 to 24 Vdc, 1 A/point, 1.2 A/4 points (max.)
AC61	Triac output	12 points (3 × 4 points/common), 100 to 240 Vac, 0.5 A/point, 0.6 A/SSR (max.)
AI21	Analog input	4 channels, 1 to 5 V / 4 to 20 mA, 8-bit resolution
AI22		4 channels, 1 to 5 V / 4 to 20 mA, 12-bit resolution
AI31		4 channels, 0 to 10 V, 8-bit resolution
AI32		4 channels, ±10 V, 12-bit resolution
AO31	Analog output	2 channels, 1 to 5 V / 4 to 20 mA / 0 to 10 V, 8-bit resolution
AO22		2 channels, 1 to 5 V / 4 to 20 mA, 12-bit resolution
AO32		2 channels, ±10 V, 12-bit resolution
PI21	Pulse input	1 channel (2-phase and zero marker), 5/12 V, 100 kHz (max.), 24-bit counter
MC11	Positioning	1 axis, 200 kHz (max.), 5 to 24 Vdc, ±999999 pulses
CF211	Communication interface	1 port of RS-232C, full-duplex, ASCII code, 300 / 600 / 1200 / 2400 / 4800 / 9600 / 19200 bps

- Internal 5 Vdc power required for the I/O modules is supplied from the T1-40(S) basic unit. See section 1.5.

1. System Configuration

1.5 Power capacity consideration

The T1-40(S) basic unit supplies internal 5 Vdc for option cards and/or I/O modules. The internal 5 Vdc output capacity of the T1-40(S) basic unit is as follows.

T1-40(S) basic unit 5 Vdc output capacity	
When both the handy programmer (HP911A) and the RS-485 port (T1-40S) are used	700 mA
When the handy programmer (HP911A) is used	800 mA
When the T1-40S's RS-485 port is used	900 mA
When neither the handy programmer (HP911A) nor the RS-485 port is used	1000 mA

The table below shows the maximum current consumption of 5 Vdc power of each card/module. When using the option cards, expansion unit and/or I/O modules, confirm that the total current consumption is within the T1-40(S)'s output capacity.

Option card / Expansion unit / I/O module			5 Vdc current consumption (max.)
Option card	16 points DC input	DI116	50 mA
	16 points DC output	DO116	50 mA
	Combination 8 inputs and 8 outputs	DD116	50 mA
	1 channel analog input 0-5V/0-20mA	AD121	260 mA
	1 channel analog input $\pm 10V$	AD131	260 mA
	1 channel analog output 0-20mA	DA121	350 mA
	1 channel analog output $\pm 10V$	DA131	240 mA
	TOSLINE-F10 remote station	FR112	100 mA
Expansion unit	24 Vdc input/relay output	T1-EDR32	120 mA
	100-120Vac input/relay output	T1-EAR32	120 mA
I/O module	16 points DC/AC input	DI31	15 mA
	32 points DC input	DI32	80 mA
	64 points DC input	DI235	100 mA
	16 points AC input (100 - 120 Vac)	IN51	15 mA
	16 points AC input (200 - 240 Vac)	IN61	15 mA
	12 points relay output	RO61	50 mA
	8 points isolated relay output	RO62	40 mA
	16 points relay output	RO263	80 mA
	16 points transistor output (sink)	DO31	60 mA
	32 points transistor output (sink)	DO32	250 mA
	64 points transistor output (sink)	DO235	250 mA
	16 points transistor output (source)	DO233P	60 mA
	12 points triac output	AC61	300 mA
	4 channels analog input (8-bit)	AI21	50 mA
		AI31	50 mA
	4 channels analog input (12-bit)	AI22	50 mA
		AI32	50 mA
	2 channels analog output (8-bit)	AO31	70 mA
	2 channels analog output (12-bit)	AO22	170 mA
		AO32	170 mA
	1 channel pulse input	PI21	80 mA
	1 axis position control	MC11	200 mA
	Communication interface	CF211	550 mA

1. System Configuration

1.6 Optional items

The following optional items related to the option cards, the I/O modules and expansion unit are available.

Item	Type	Description	
Option card I/O connector	PT15S	Cable side connector for DI116, DO116, or DD116	Soldering type
	PT15F		Flat cable type
Empty slot cover	EX10*ABP1	For covering empty slot on the expansion rack	
Expansion rack cable	CS1R2	For connecting the expansion rack, 0.15 m length (spare parts)	
Expansion unit cable	CS1R5E	For Connecting the expansion unit, 0.5m length (spare parts)	

Note) The I/O connector (cable side connector) for the discrete I/O option card (DI116, DO116 or DD116) is also available on the market. Refer to the followings.

Connector maker: Fujitsu

- (1) Card side (PWB side) connector
Type: FCN-365P024-AU
- (2) Cable side connector [soldering type]
Type: FCN-361J024-AU (connector)
Type: FCN-360C024-E (cover)
- (3) Cable side connector [flat cable type]
Type: FCN-367J024-AU/F

Use above (2) or (3).

Section 2

Specifications

- 2.1 Option card, 16*
- 2.2 Expansion unit, 28*
- 2.3 T2 I/O module, 31*

2. Specifications

2.1 Option card

- 16 points DC input

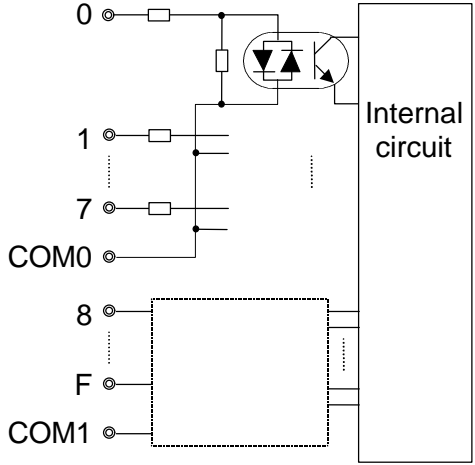
Item	DI116
Card type	DC input, current sourcing/sinking
I/O allocation type	X 1W (1 input register XW assigned)
Number of input points	16 points (8 points/common)
Rated input voltage	24 Vdc, +10/-15 %
Rated input current	5 mA (at 24 Vdc)
Minimum ON voltage	18.0 Vdc
Maximum OFF voltage	6.0 Vdc
ON delay time	10 ms
OFF delay time	10 ms
De-rating condition	See Note on the next page
Input signal display	None
External connection	24-pin connector
Withstand voltage	1500 Vac, 1 minute (internal ↔ external circuits)
Current consumption	Max. 50 mA (5 Vdc)
Internal circuit	

2. Specifications

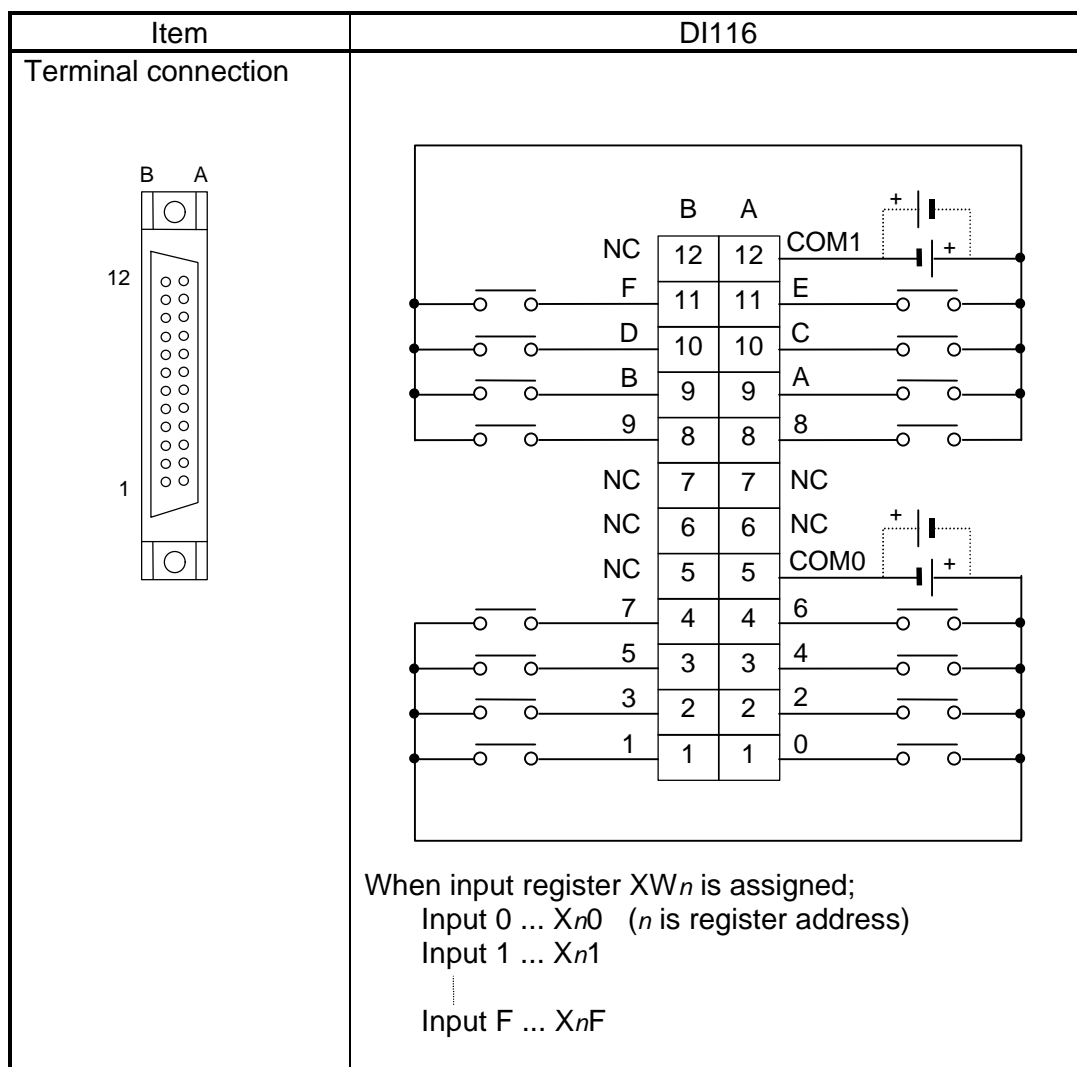

Note) As for the DC input, there is the following de-rating condition for maximum number of simultaneous ON points, depending on the ambient temperature.

Simultaneous ON points (per common)

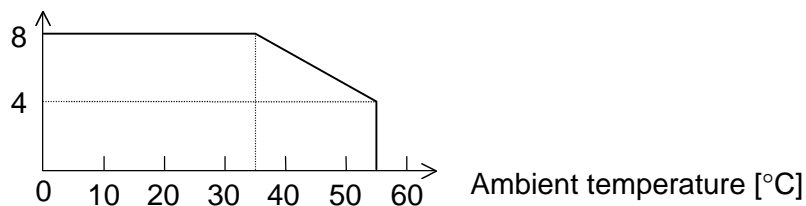

2. Specifications

- 16 points DC output

Item	DO116
Card type	Transistor output, current sinking
I/O allocation type	Y 1W (1 output register YW assigned)
Number of output points	16 points (8 points/common)
Rated load voltage	5 to 24 Vdc, +10/-5 %
Maximum load current	100 mA/point (at 24 Vdc), 20 mA/point (at 5 Vdc), 800 mA/common
Voltage drop at ON	0.4 V or less
Leakage current at OFF	100 μ A
ON delay time	1 ms
OFF delay time	2 ms
Output signal display	None
External connection	24-pin connector
Withstand voltage	1500 Vac, 1 minute (internal \leftrightarrow external circuits)
Current consumption	Max. 50 mA (5 Vdc)
Internal circuit	

2. Specifications

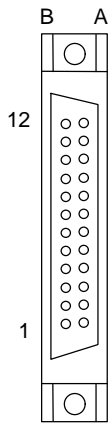
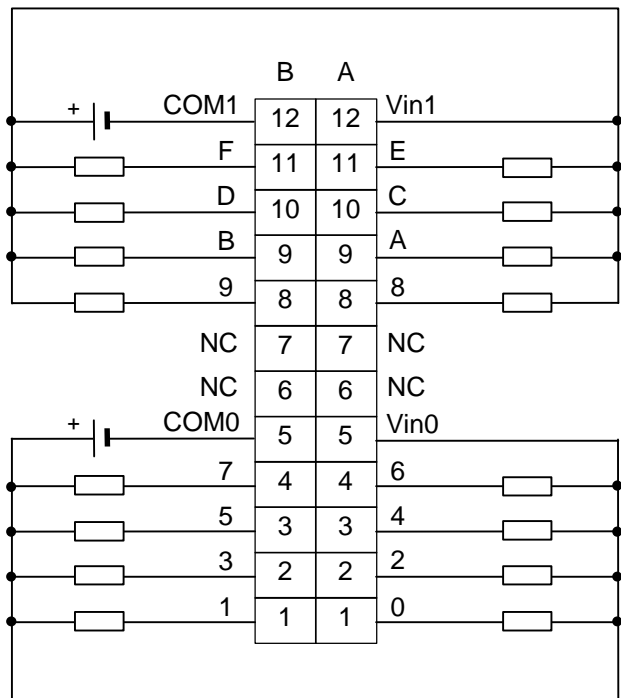
Item	DO116
<p>Terminal connection</p> 	 <p>When output register YW_n is assigned; Output 0 ... Y_{n0} (n is register address) Output 1 ... Y_{n1} ⋮ Output F ... Y_{nF}</p>

2. Specifications

- 8 points DC input and 8 points DC output combined

Item		DD116
Card type		DC input (current sinking/sourcing), Transistor output (current sinking), combined
I/O allocation type		X+Y 2W (1 input XW and 1 output YW registers assigned)
Input	Number of input points	8 points (8 points/common)
	Rated input voltage	24 Vdc, +10/-15 %
	Rated input current	5 mA (at 24 Vdc)
	Minimum ON voltage	18.0 Vdc
	Maximum OFF voltage	6.0 Vdc
	ON delay time	10 ms
	OFF delay time	10 ms
	De-rating condition	See Note on the next page
Output	Number of output points	8 points (8 points/common)
	Rated load voltage	5 to 24 Vdc, +10/-5 %
	Maximum load current	100 mA/point (at 24 Vdc), 20 mA/point (at 5 Vdc), 800 mA/common
	Voltage drop at ON	0.4 V or less
	Leakage current at OFF	100 μ A
	ON delay time	1 ms
	OFF delay time	2 ms
I/O signal display		None
External connection		24-pin connector
Withstand voltage		1500 Vac, 1 minute (internal \leftrightarrow external circuits)
Current consumption		Max. 50 mA (5 Vdc)
Internal circuit		

2. Specifications

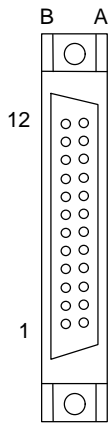
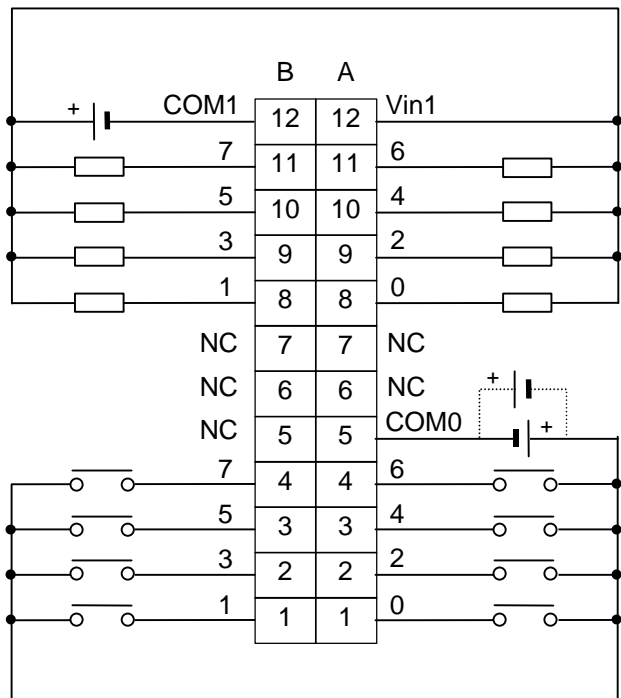
Item	DD116																																																				
<p>Terminal connection</p> 	 <table style="margin: 10px auto; border-collapse: collapse;"> <thead> <tr> <th></th> <th style="text-align: center;">B</th> <th style="text-align: center;">A</th> <th></th> </tr> </thead> <tbody> <tr> <td style="text-align: center;">COM1</td> <td style="text-align: center;">12</td> <td style="text-align: center;">12</td> <td style="text-align: center;">Vin1</td> </tr> <tr> <td style="text-align: center;">7</td> <td style="text-align: center;">11</td> <td style="text-align: center;">11</td> <td style="text-align: center;">6</td> </tr> <tr> <td style="text-align: center;">5</td> <td style="text-align: center;">10</td> <td style="text-align: center;">10</td> <td style="text-align: center;">4</td> </tr> <tr> <td style="text-align: center;">3</td> <td style="text-align: center;">9</td> <td style="text-align: center;">9</td> <td style="text-align: center;">2</td> </tr> <tr> <td style="text-align: center;">1</td> <td style="text-align: center;">8</td> <td style="text-align: center;">8</td> <td style="text-align: center;">0</td> </tr> <tr> <td style="text-align: center;">NC</td> <td style="text-align: center;">7</td> <td style="text-align: center;">7</td> <td style="text-align: center;">NC</td> </tr> <tr> <td style="text-align: center;">NC</td> <td style="text-align: center;">6</td> <td style="text-align: center;">6</td> <td style="text-align: center;">NC</td> </tr> <tr> <td style="text-align: center;">NC</td> <td style="text-align: center;">5</td> <td style="text-align: center;">5</td> <td style="text-align: center;">COM0</td> </tr> <tr> <td style="text-align: center;">7</td> <td style="text-align: center;">4</td> <td style="text-align: center;">4</td> <td style="text-align: center;">6</td> </tr> <tr> <td style="text-align: center;">5</td> <td style="text-align: center;">3</td> <td style="text-align: center;">3</td> <td style="text-align: center;">4</td> </tr> <tr> <td style="text-align: center;">3</td> <td style="text-align: center;">2</td> <td style="text-align: center;">2</td> <td style="text-align: center;">2</td> </tr> <tr> <td style="text-align: center;">1</td> <td style="text-align: center;">1</td> <td style="text-align: center;">1</td> <td style="text-align: center;">0</td> </tr> </tbody> </table> <p>When input register XW_n and output register YW_{n+1} is assigned;</p> <p style="margin-left: 20px;">Input 0 X_{n0} (n is register address)</p> <p style="margin-left: 20px;">⋮</p> <p style="margin-left: 20px;">Input 7 X_{n7}</p> <p style="margin-left: 20px;">Output 0 ... Y_{n+10} ($n+1$ is next register address of n)</p> <p style="margin-left: 20px;">⋮</p> <p style="margin-left: 20px;">Output 7 ... Y_{n+17}</p>		B	A		COM1	12	12	Vin1	7	11	11	6	5	10	10	4	3	9	9	2	1	8	8	0	NC	7	7	NC	NC	6	6	NC	NC	5	5	COM0	7	4	4	6	5	3	3	4	3	2	2	2	1	1	1	0
	B	A																																																			
COM1	12	12	Vin1																																																		
7	11	11	6																																																		
5	10	10	4																																																		
3	9	9	2																																																		
1	8	8	0																																																		
NC	7	7	NC																																																		
NC	6	6	NC																																																		
NC	5	5	COM0																																																		
7	4	4	6																																																		
5	3	3	4																																																		
3	2	2	2																																																		
1	1	1	0																																																		

Note) As for the DC input, there is the following de-rating condition for maximum number of simultaneous ON points, depending on the ambient temperature.

Simultaneous ON points (per common)

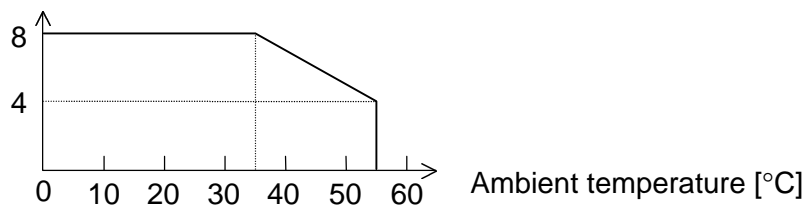

2. Specifications

- 1 channel analog input (0-5V/0-20mA)

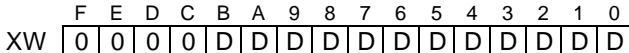
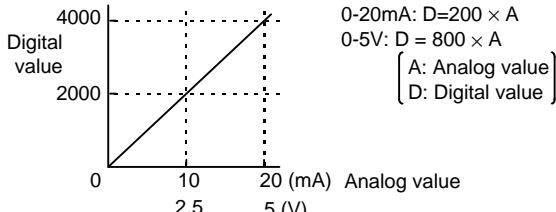
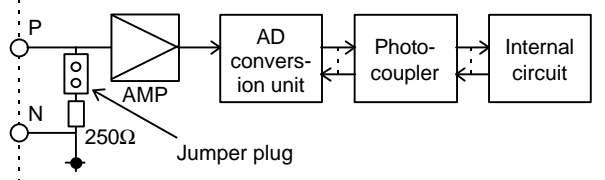
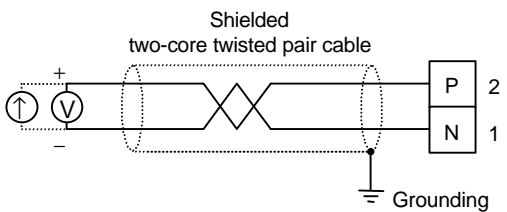
Item	AD121	
Card type	Analog input	
I/O allocation type	X 1W (1 input XW register assigned)	
Number of input points	1 channel	
Resolution	12 bits (1/4000)	
Rated input range	0 - 5 V	0 - 20 mA
Absolute max. input	±7 V	±25 mA
Rated input impedance	1 MΩ or more	250 Ω
Overall accuracy	±0.5 % FS : 25°C ±1 % FS : 0 to 55°C	
Conversion cycle	2ms	
External power supply	None	
Insulation	Photo-coupler	
I/O signal display	None	
External connection	2-pin removable connector	
Withstand voltage	500 Vac, 1 minute (internal ↔ external circuits)	
Current consumption	Max. 260 mA (5 Vdc)	
Input range setting (jumper plug JP1)	Open	Short (factory setting)
Data format	Converts full scale analog input signal (0-20mA/0-5V) into digital data in 0 to 4000.  D: Data bit (12bits) 0 - 4000 (H0000 - H0FA0) 	
Internal circuit		
Terminal connection		

2. Specifications

- 1 channel analog input ($\pm 10V$)

Item	AD131
Card type	Analog input
I/O allocation type	X 1W (1 input XW register assigned)
Number of input points	1 channel
Resolution	12 bits (1/4000)
Rated input range	$\pm 10 V$
Absolute max. input	$\pm 13 V$
Rated input impedance	1 M Ω or more
Overall accuracy	$\pm 0.5 \% FS : 25^{\circ}C$ $\pm 1 \% FS : 0 \text{ to } 55^{\circ}C$
Conversion cycle	2ms
External power supply	None
Insulation	Photo-coupler
I/O signal display	None
External connection	2-pin removable connector
Withstand voltage	500 Vac, 1 minute (internal \leftrightarrow external circuits)
Current consumption	Max. 260 mA (5 Vdc)
Data format	<p>Converts full scale analog input signal ($\pm 10V$) into digital data in -2000 to +2000.</p> <p style="text-align: center;"> F E D C B A 9 8 7 6 5 4 3 2 1 0 </p> <p style="text-align: center;">XW S S S S S D D D D D D D D D D D D D</p> <p>S: Sign 0 = positive, 1 = negative D: Data bit (11bits) -2000 - 2000 (HF830 - H07D0) A negative value is expressed by 2's complement</p> <div style="display: flex; align-items: center; justify-content: center;"> <div style="text-align: center;"> <p>Digital value</p> <p>Analog value (V)</p> </div> <div style="margin-left: 20px;"> <p>$D = 200 \times A$</p> <p>[A: Analog value] [D: Digital value]</p> </div> </div>
Internal circuit	
Terminal connection	<p style="text-align: center;">Shielded two-core twisted pair cable</p> <p style="text-align: center;">Grounding</p>

2. Specifications

- 1 channel analog output (0-20mA)

Item	DA121
Card type	Analog output
I/O allocation type	Y 1W (1 output YW register assigned)
Number of input points	1 points
Resolution	12 bits (1/4000)
Rated input range	0 - 20 mA
Rated input impedance	600 Ω or less
Overall accuracy	±0.5 % FS : 25°C ±1 % FS : 0 to 55°C
Conversion cycle	2ms
External power supply	None
Insulation	Photo-coupler
I/O signal display	None
External connection	2-pin removable connector
Withstand voltage	500 Vac, 1 minute (internal ↔ external circuits)
Current consumption	Max. 350 mA (5 Vdc)
Data format	<p>Converts digital data in 0 to 4000 into analog signal in full scale (0-20mA)</p> <p style="text-align: center;"> F E D C B A 9 8 7 6 5 4 3 2 1 0 YW * * * * D D D D D D D D D D D D </p> <p>D: Data bit (12bits) 0 - 4000 (H0000 - H0FA0) *: No effect on D/A conversion</p> <p style="text-align: right;"> $A = 0.005 \times D$ [A: Analog value] [D: Digital value] </p>
Internal circuit	
Terminal connection	

2. Specifications

- 1 channel analog output ($\pm 10V$)

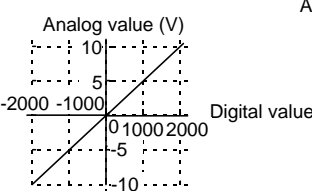
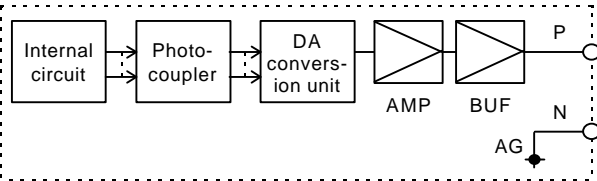
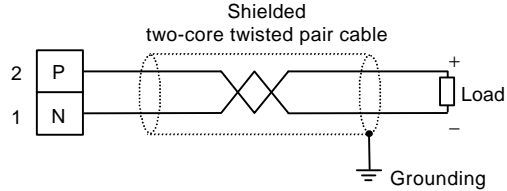
Item	DA131
Card type	Analog output
I/O allocation type	Y 1W (1 output YW register assigned)
Number of output points	1 channel
Resolution	12 bits (1/4000)
Rated output range	$\pm 10V$
Rated output impedance	10k Ω or more
Overall accuracy	$\pm 0.5\%$ FS : 25°C $\pm 1\%$ FS : 0 to 55°C
Conversion cycle	2ms
External power supply	None
Insulation	Photo-couple
I/O signal display	None
External connection	2-pin removable connector
Withstand voltage	500 Vac, 1 minute (internal \leftrightarrow external circuits)
Current consumption	Max. 240 mA (5Vdc)
Data format	<p>Converts digital data in -2000 to +2000 into analog signal in full scale ($\pm 10V$)</p> <p style="text-align: center;"> F E D C B A 9 8 7 6 5 4 3 2 1 0 YW S S S S S D D D D D D D D D D </p> <p>S: Sign 0 = positive, 1 = negative D: Data bit (11bits) -2000 - 2000 (HF830 - H07D0) A negative value is expressed by 2's complement</p> <p style="text-align: center;"> $A = 0.005 \times D$ [A: Analog value] [D: Digital value] </p> 
Internal circuit	
Terminal connection	

2. Specifications

- TOSLINE-F10 remote station

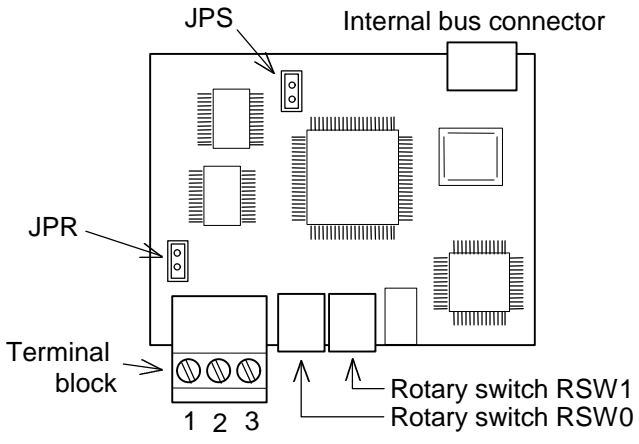
Item		FR112
Card type		TOSLINE-F10 remote station
I/O allocation type		TL-F (no I/O register assigned)
TOSLINE-F10 system	Transmission cable	Shielded twisted-pair cable
	Configuration	Bus (party line)
	Transmission speed	750 kbps or 250 kbps
	Transmission distance	Max. 500 m (750 kbps) Max. 1 km (250 kbps)
	Transmission data capacity (cyclic scan)	Max. 32 words (512 points)
	Scan cycle	7 ms/32 words (750 kbps) 12 ms/32 words (250 kbps)
	Error checking	CRC check
FR112 function	Register assignment	SW34 ... Data send to the master SW35 ... Data receive from the master (2 words of transmission data shared)
	Transmission speed	750 kbps or 250 kbps, Jumper selection (JPS)
	Transmission line termination	Jumper selection (JPR)
	Receive data at transmission error	Previous data is held (TOSLINE-F10 error flag S00D comes ON)
Status display		None
External connection		3-pin removable terminal block
Current consumption		Max. 100 mA (5 Vdc)
Jumper settings		 <p>JPS: Transmission speed Open ... 750 kbps Short ... 250 kbps</p> <p>JPR: Termination resistor Open ... No connect Short ... Connect</p>

2. Specifications

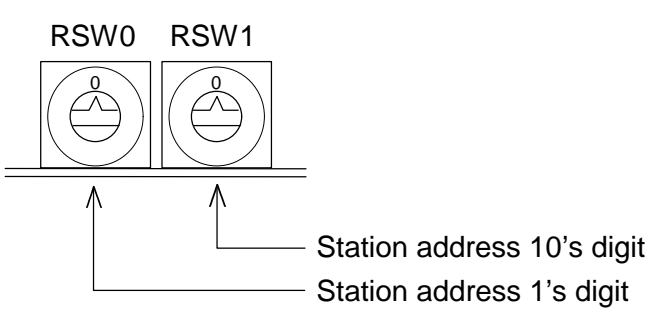
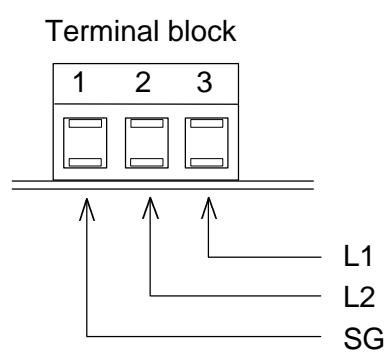
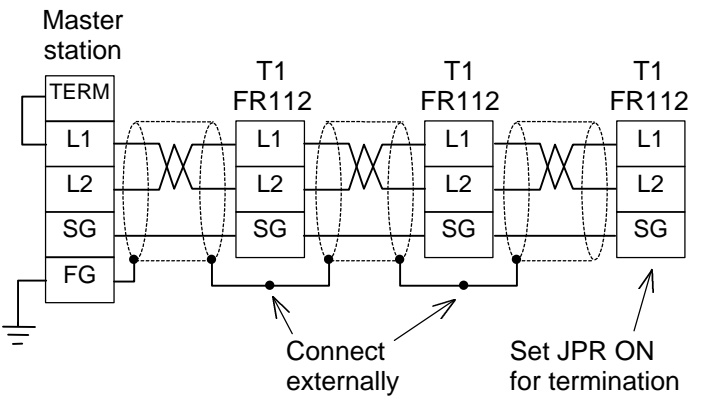
Item	FR112
Station address setting	<div style="text-align: center;">  <p style="text-align: right;">Station address 10's digit Station address 1's digit</p> </div> <p style="text-align: center;">Allowable station address: 0 to 30</p>
Transmission cable connection	<div style="text-align: center;">  <p style="text-align: right;">L1 L2 SG</p> </div> <div style="text-align: center; margin-top: 20px;">  <p style="text-align: center;">Connect externally Set JPR ON for termination</p> </div>

Note) Refer to the TOSLINE-F10 manual for details of the TOSLINE-F10 system.

2. Specifications

2.2 Expansion unit

- 16 points DC input and 16 points Relay output (T1-EDR32)
- 16 points AC input and 16 points Relay output (T1-EAR32)

Input specifications

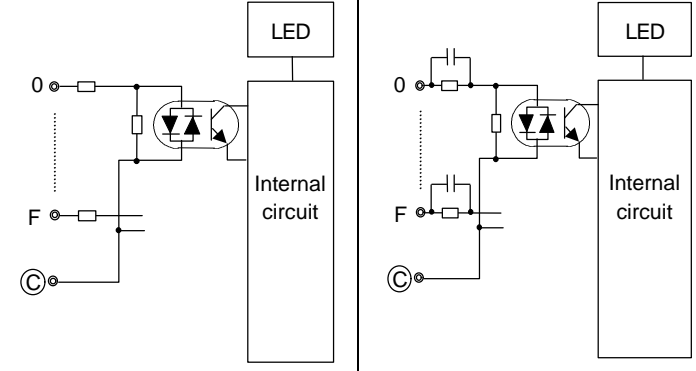
Item	Input Specifications	
	EDR32	EAR32
Input type	DC input	AC input
Input points	16 points (16 points/common)	
Rated input voltage	24 Vdc, +10/-15%	100 - 120 Vac, +10/-15% 50/60 Hz
Rated input current	7 mA (at 24 Vdc)	7 mA (at 100 Vdc)
Min. ON voltage	15 Vdc	80 Vac
Max. OFF voltage	5 Vdc	30 Vac
ON delay time	10 ms or less	25 ms or less
OFF delay time	10 ms or less	30 ms or less
Input signal display	LED display for all points, lit at ON, internal logic side	
External connection	Removable terminal block, M3.5	
Withstand voltage	1500 Vac, 1 minute (between internal and external circuits)	
Internal circuit		

2. Specifications

Output specifications

Item	Output Specifications	
	EDR32	EAR32
Output type	Relay output, normally open	
Output points	16 points (8 x isolated, 2 x 4 points/common)	
Rated load voltage	240 Vac / 24 Vdc, +10% (max.)	
Maximum load current	2A/point (resistive), 4A/common	
ON resistance	50 mΩ or less (initial value)	
Leakage current at OFF	None	
Minimum load	5 Vdc, 10 mA (50 mW)	
OFF delay time	10 ms or less	
OFF delay time	10 ms or less	
Output signal display	LED display for all points, lit at ON, internal logic side	
External connection	Removable terminal block, M3.5	
Withstand voltage	1500 Vac, 1 minute (between internal and external circuits)	
Internal circuit	<p>The diagram illustrates the internal circuit of the output stage. It features an LED connected to the internal circuit. The internal circuit includes a transistor that drives a relay (Ry). The relay coil is connected to a 24Vdc+ supply and a 24Vdc- supply. The relay has multiple terminals: 10, 17, 18, 1B, C1, 1C, 1F, and C2. The LED is also connected to the 24Vdc+ and 24Vdc- supplies.</p>	

2. Specifications

Terminal connections

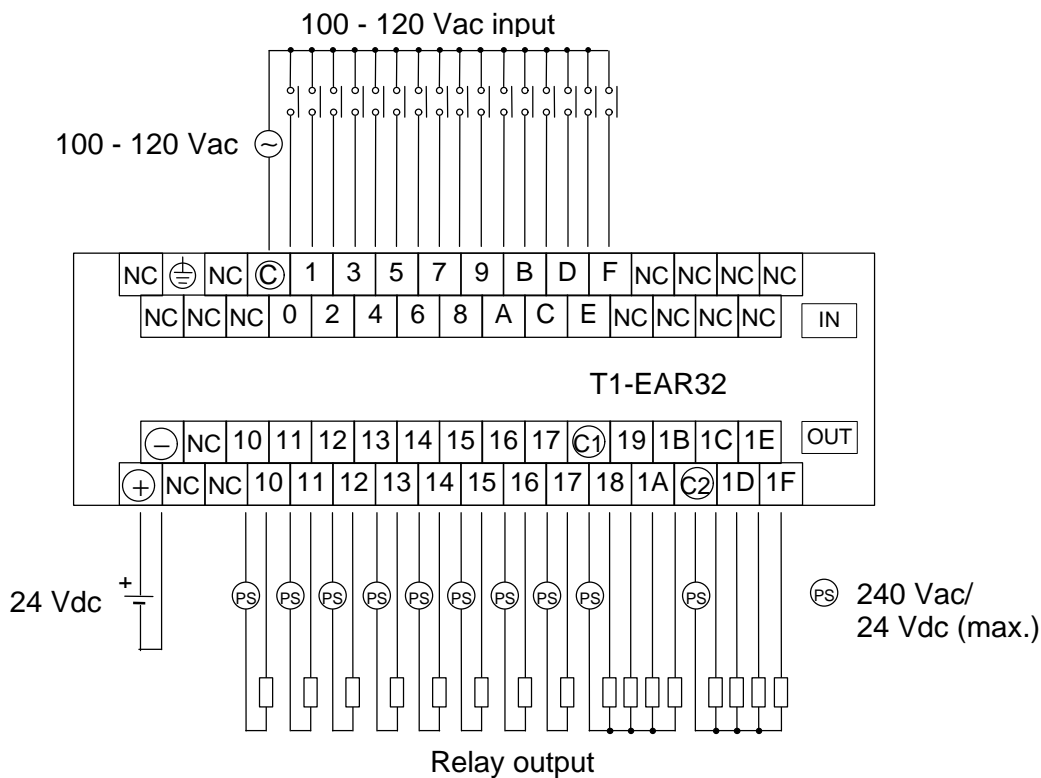
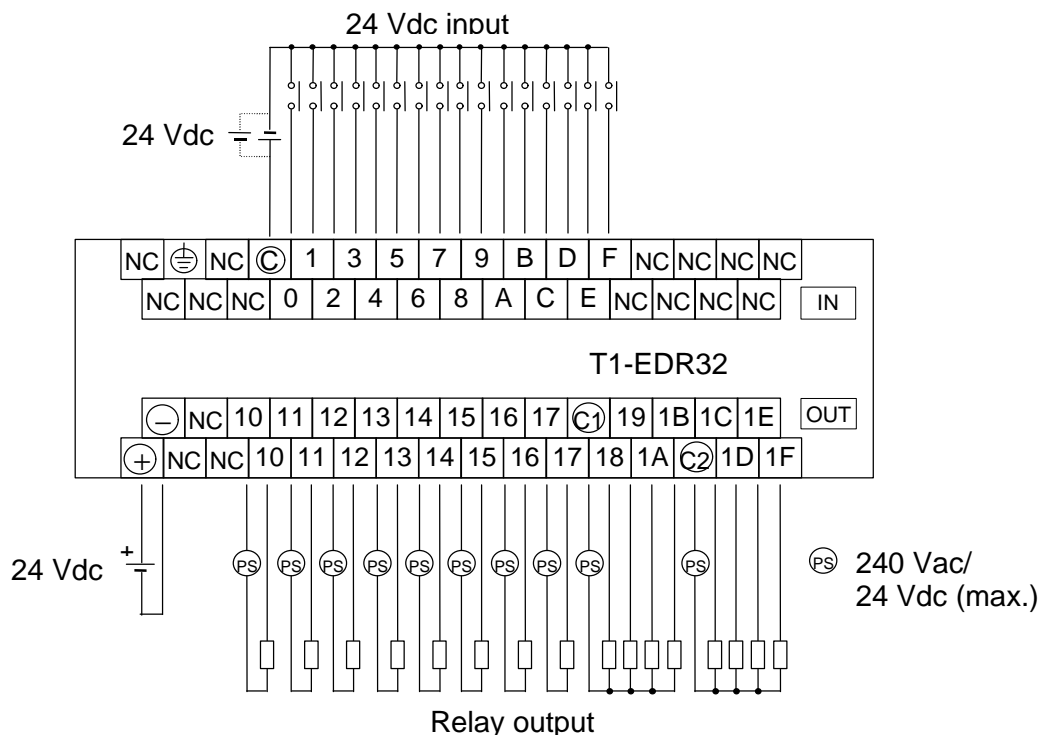

2. Specifications

2.3 T2 I/O module

- 16 points DC/AC input

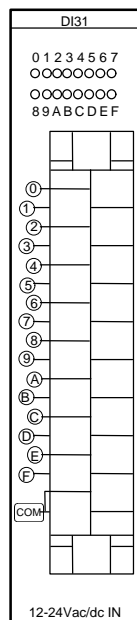

Item	DI31 (EX10*MDI31)	
Input Voltage	12 - 24 V dc/ac, +10/-15 % (DC or 50/60 Hz)	
Minimum ON Voltage	9.6 V	
Maximum OFF Voltage	3.6 V (leakage current 0.7 mA or less)	
Input Current	Approx. 8 mA (at 24 Vdc) (typ.)	
Number of Input Points	16 points (single common)	
ON Delay	N Mode	10 ms or less (dc) / 20 ms or less (ac)
	H Mode	1.5 ms or less (dc)
OFF Delay	N Mode	10 ms or less (dc) / 15 ms or less (ac)
	H Mode	1.5 ms or less (dc)
Withstand Voltage	1500 Vac for 1 minute	
Current Consumption	15 mA (5 Vdc) or less	

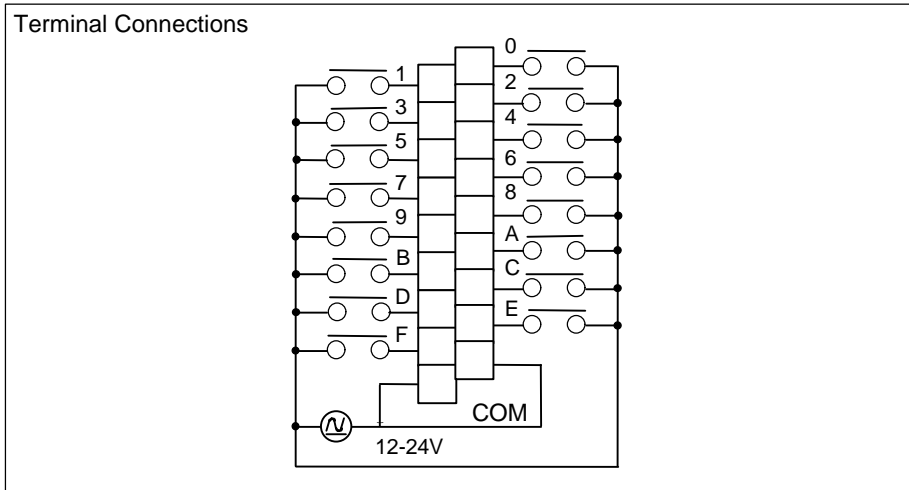
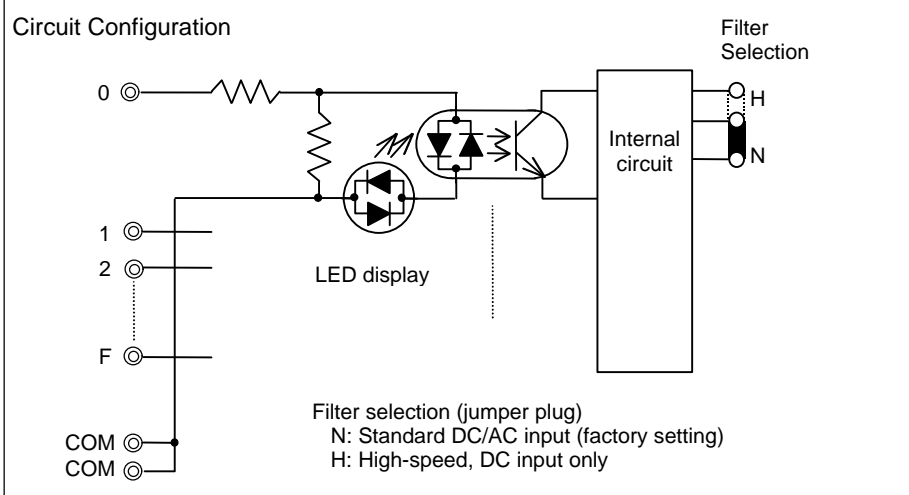

2. Specifications

- 32 points DC input

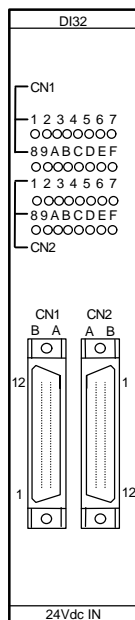

Item		DI32 (EX10*MDI32)
Input Voltage		24 Vdc, +10/-15 %
Minimum ON Voltage		18.0 V
Maximum OFF Voltage		6.0 V
Input Current		Approx. 5 mA (at 24 Vdc) (typ.)
Number of Input Points		32 points
ON Delay	N Mode	10 ms or less
	H Mode	1.5 ms or less
OFF Delay	N Mode	10 ms or less
	H Mode	1.5 ms or less
External Connections		2 x 24-pin connectors
Common Configuration	Number of Commons	4
	Input Points per Common	8 points/common
	Common Polarity	No Polarity
Withstand Voltage		1500 Vac for 1 minute
Current Consumption		80 mA (5 Vdc) or less

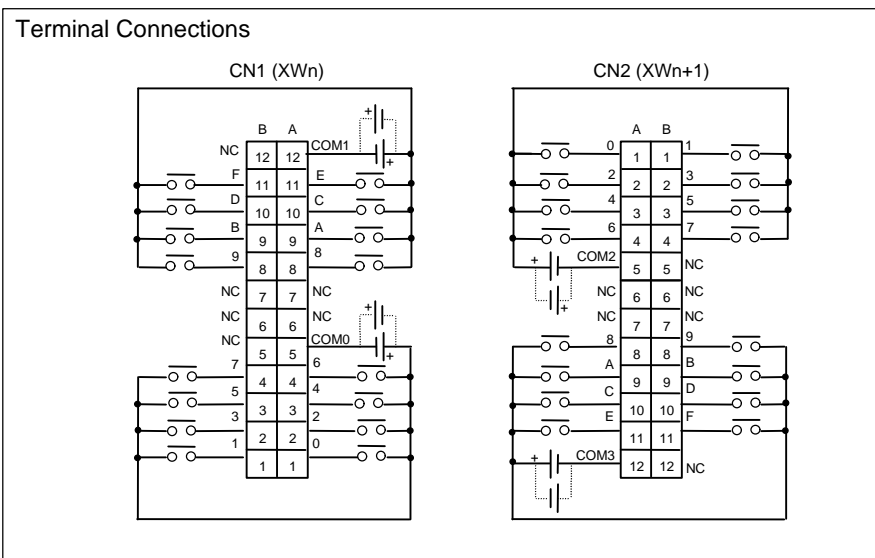
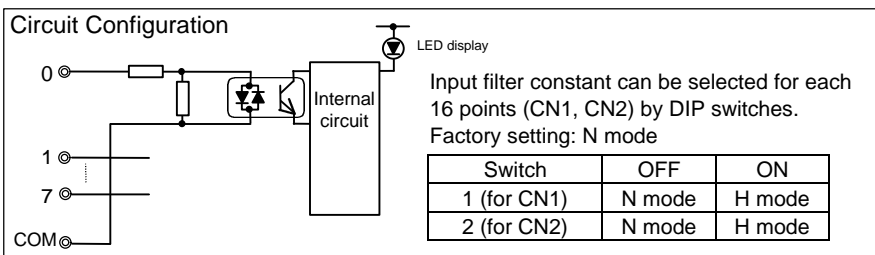

Note) Cable side connectors (soldering type) are attached as standard.

2. Specifications

- 64 points DC input

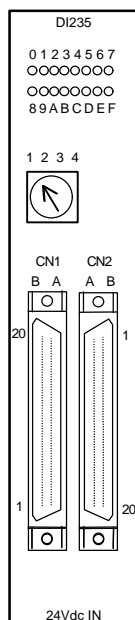

Item		DI235 (TDI235**S)
Input Voltage		24 Vdc, +10/-15 %
Input Current		Approx. 4 mA (at 24 Vdc) (typ.)
Input Impedance		5.8 kΩ (at 24 Vdc)
Minimum ON Voltage		16 V
Maximum OFF Voltage		5 V
ON Delay		10 ms or less
OFF Delay		15 ms or less
External Connections		2 x 40-pin connectors
Common Configuration	Number of Commons	8
	Input Points per Common	8 points/common
	Common Polarity	No Polarity
Derating Condition		See Note below
Withstand Voltage		1500 Vac for 1 minute
Current Consumption		100 mA (5 Vdc) or less
Circuit Configuration		

Note) Derating condition:

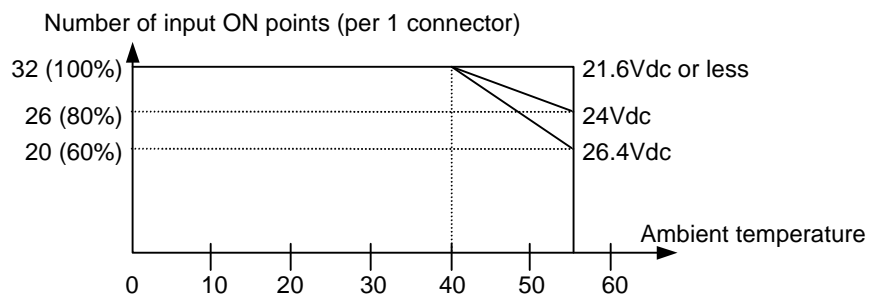

2. Specifications

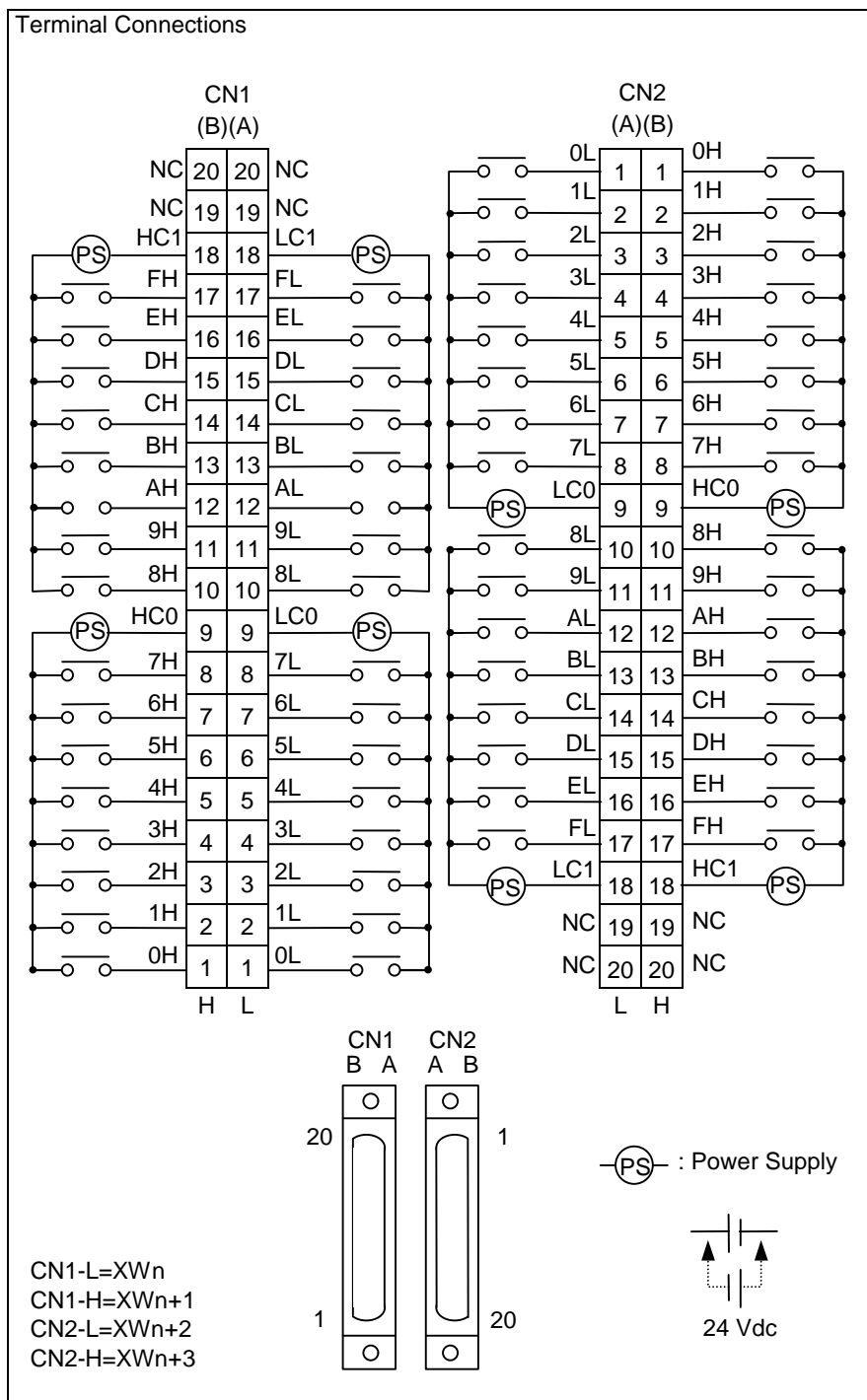

Note) Cable side connectors (soldering type) are attached as standard.

2. Specifications

- 16 points AC input

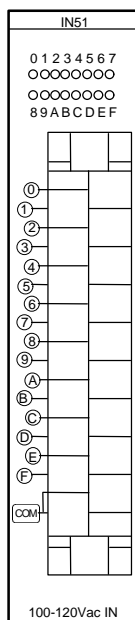

Item	IN51 (EX10*MIN51)	IN61 (EX10*MIN61)
Input Voltage (Sine wave)	100 - 120 Vac, +10/-15 % (50/60 Hz)	200 - 240 Vac, +10/-15 % (50/60 Hz)
Minimum ON voltage (Sine wave)	80 Vac	160 Vac
Maximum OFF voltage (Sine wave)	30 Vac (leak current 2 mA or less)	60 Vac (leak current 2 mA or less)
Input Current (Sine wave)	Approx. 7 mA (100V-50Hz)	Approx. 6 mA (200V-50Hz)
Number of Input Points	16 points (single common)	16 points (single common)
ON Delay (Sine wave)	20 ms or less	20 ms or less
OFF Delay (Sine wave)	15 ms or less	15 ms or less
Withstand Voltage	1500 Vac for 1 minute	1500 Vac for 1 minute
Current Consumption	15 mA (5 Vdc) or less	15 mA (5 Vdc) or less

Circuit Configuration

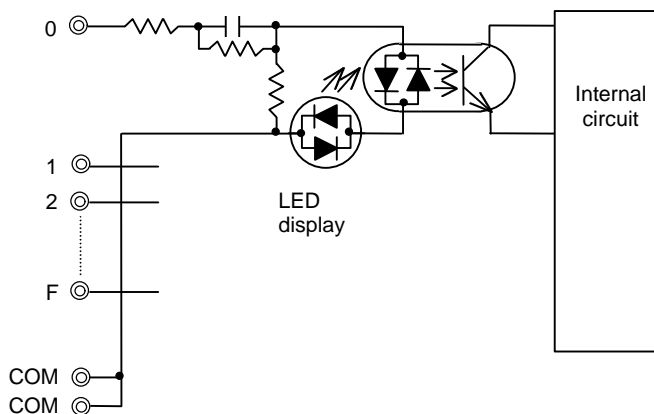

Terminal connections

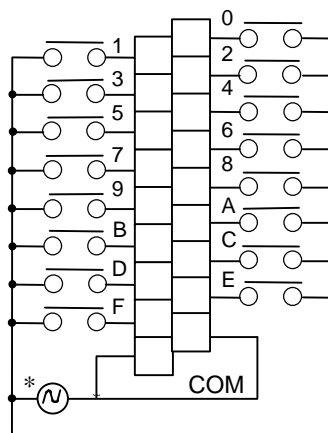

*
IN51: 100 - 120 Vac (50/60 Hz)
IN61: 200 - 240 Vac (50/60 Hz)

2. Specifications

- 12 points relay output

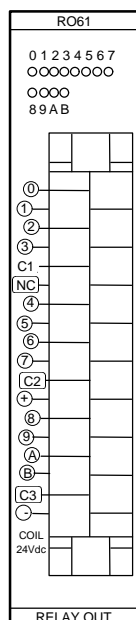

Item	RO61 (EX10*MRO61)
Load Voltage	24 Vdc, +20 % (MAX) / 240 Vac, +10% (MAX)
Maximum Load	2 A/point (resistive load), 1 A/point (inductive load), 4 A/4 points common
Minimum Load	50 mW (5 V or more)
Number of Output Points	12 points (4 points / common)
ON Delay	10 ms or less
OFF Delay	15 ms or less
Leakage Current at OFF	0 mA
Withstand Voltage	1500 Vac for 1 minute
Over-current Protection	None (required externally)
Current Consumption	50 mA (5 Vdc) or less
External Power Required for Relay Coil	24 Vdc, +/-10% – 140 mA / all points ON (10 mA / point)

Circuit Configuration

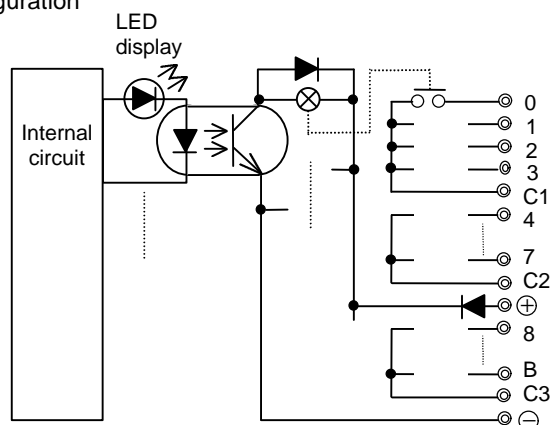

Terminal Connections

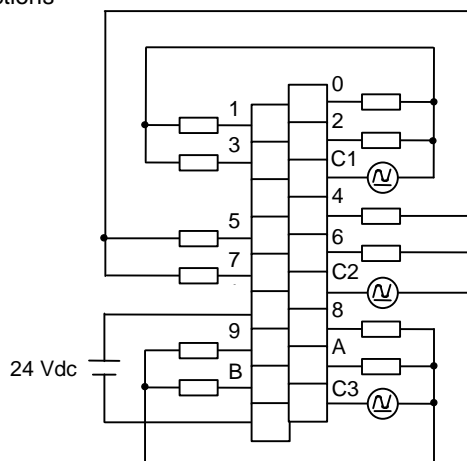

Note)

- ON/OFF life of relays: Electrical 100,000 times
Mechanical 20 million times
- No overload protection fuses are built into this module. Therefore make sure to insert fuses suitable to the load current.

2. Specifications

- 8 points isolated relay output

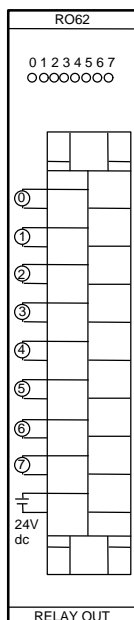

Item	RO62 (EX10*MRO62)
Load Voltage	24 Vdc, +20% (MAX) / 240 Vac, +10% (MAX)
Maximum Load	2 A / point (resistive load), 1 A / point (inductive load)
Minimum Load	50 mW (5 V or more)
Number of Output Points	8 points (each point isolated)
ON Delay	10 ms or less
OFF Delay	15 ms or less
Leakage Current at OFF	0 mA
Withstand Voltage	1500 Vac for 1 minute
Over-current Protection	None (required externally)
Current consumption	40 mA (5 Vdc) or less
External Power Required for Relay Coil	24 Vdc, +/-10% - 100 mA / all points ON (10 mA / point)

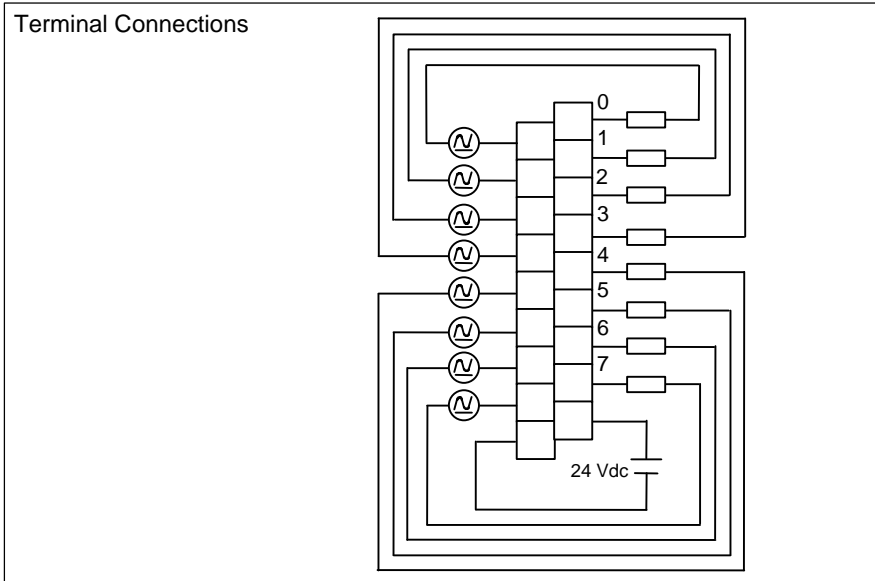
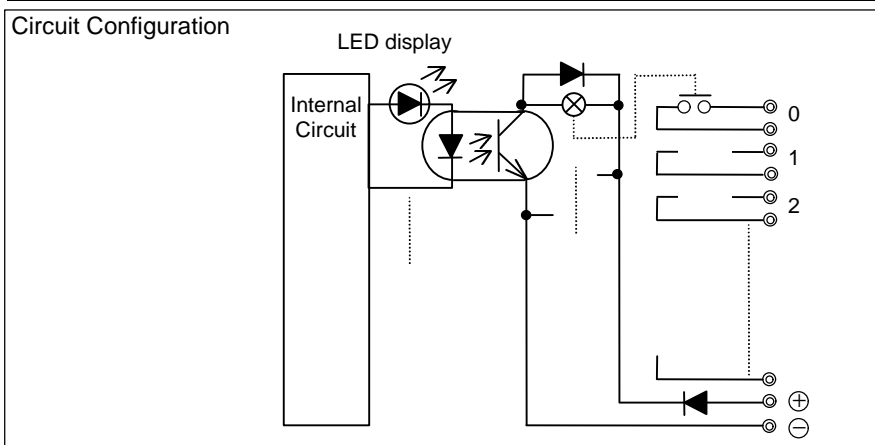

Note)

- ON/OFF life of relays: Electrical 100,000 times
Mechanical 20 million times
- No overload protection fuses are built into this module. Therefore make sure to insert fuses suitable to the load current.

2. Specifications

- 16 points relay output

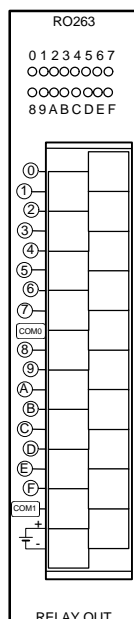

Item	RO263 (TRO263**S)
Load Voltage	24 Vdc, +25 % (MAX) / 240 Vac, +10% (MAX)
Maximum Load	2 A / point (resistive load), 8 A / 8 points common
Minimum Load	50 mW (5 V or more)
Number of Output Points	16 points (8 points / common)
ON Delay	10 ms or less
OFF Delay	15 ms or less
Leakage Current at OFF	0 mA
Withstand Voltage	1500 Vac for 1 minute
Over-current Protection	None (required externally)
Current Consumption	80 mA (5 Vdc) or less
External Power Required for Relay Coil	24 Vdc, +/-10% – 90 mA / all points ON

Circuit Configuration

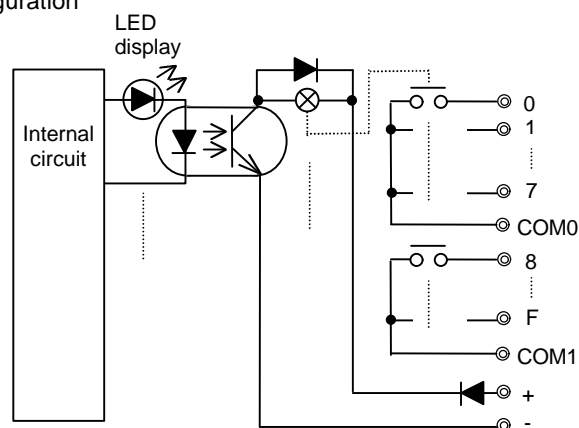

Terminal Connections

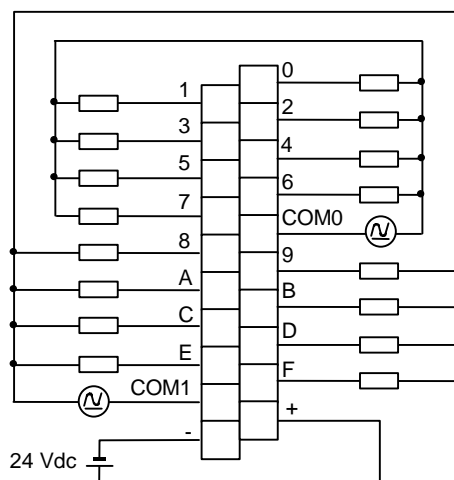

Note)

- ON/OFF life of relays: Electrical 100,000 times
Mechanical 20 million times
- No overload protection fuses are built into this module. Therefore make sure to insert fuses suitable to the load current.

2. Specifications

- 16 points transistor output

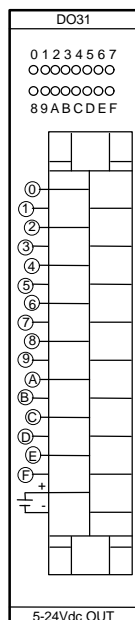

Item	DO31 (EX10*MDO31)
Load Voltage	5 - 24 Vdc, +10/-5% (Internal current consumption 35 mA or less)
Output Current	1 A / point (load voltage 7 V or more) 0.3 A / point (load voltage less than 7 V) 1.2A / 4 points (4-element transistor array)
Output ON Resistance	1.5 Ω or less
Number of Output Points	16 points (single common, current sinking)
ON Delay	1 ms or less
OFF Delay	1 ms or less
Leakage Current at OFF	0.1 mA or less
Withstand Voltage	1500 Vac for 1 minute
Over-current Protection	Built-in 5 A fuse (per common)
Current Consumption	60 mA (5 Vdc) or less

Circuit Configuration

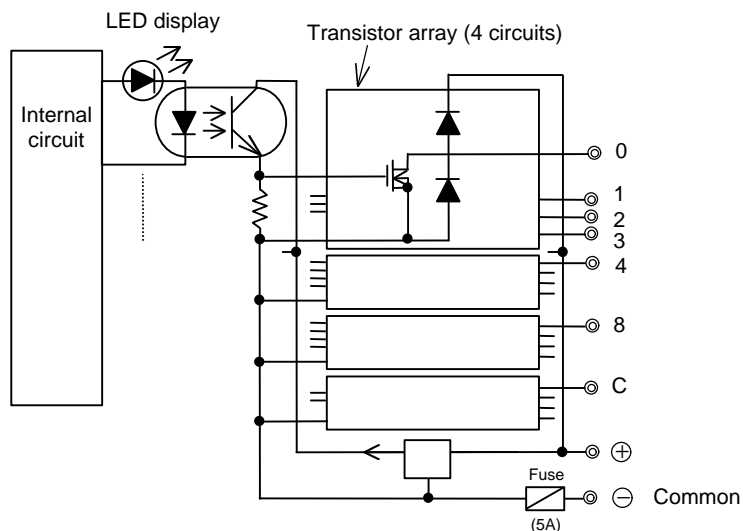

Terminal Connections

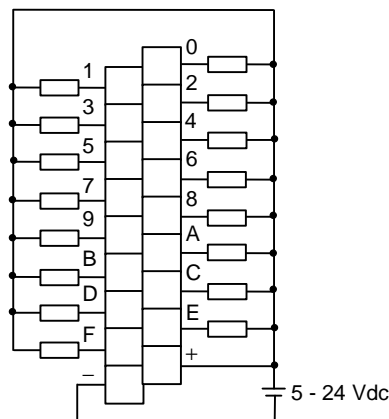

2. Specifications

- 32 points transistor output

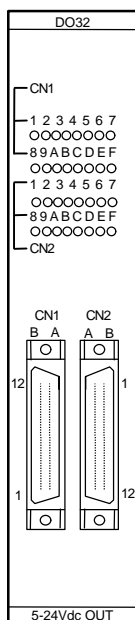

Item		DO32 (EX10*MDO32)
Load Voltage		5 - 24 Vdc, +10/-5 %
Output Current		100 mA / point (when load voltage 24 V) 20 mA / point (when load voltage 5 V) 800 mA / common
Voltage Drop at ON		0.4 V or less
Number of Output Points		32 points (8 points/common, current sinking)
ON Delay		1 ms or less
OFF Delay		2 ms or less
Leakage Current at OFF		0.1 mA or less
External Connections		2 x 24 pin connectors
Common configuration	Number of Commons	4
	Output Points per Common	8 points
	Common Polarity	Minus common
Withstand Voltage		1500 Vac for 1 minute
Over-current Protection		Built-in 2 A fuse (per common)
Current Consumption		250 mA (5 Vdc) or less

Circuit Configuration

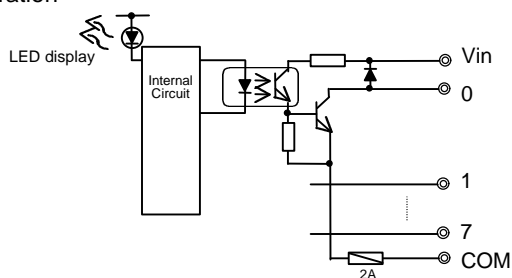

Terminal Connections

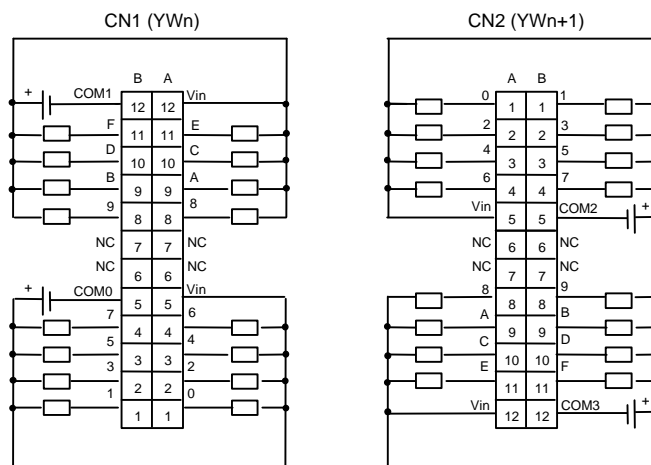

Note) Cable side connectors (soldering type) are attached as standard.

2. Specifications

- 64 points transistor output

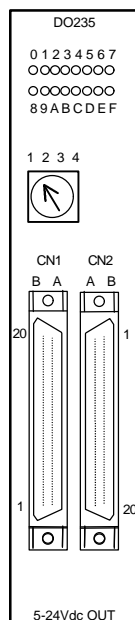

Item	DO235 (TDO235**S)	
Load Voltage	5 - 24 Vdc, +10/-5%	
Output Current	0.1 A / point (9.6 - 26.4 Vdc) 0.05 A / point (4.5 - 9.5 Vdc)	
Voltage Drop at ON	0.4 V or less	
Number of Output Points	64 points (8 points/common, current sinking)	
ON Delay	1 ms or less	
OFF Delay	1 ms or less	
Leakage Current at OFF	0.1 mA or less (24 Vdc)	
External Connections	2 x 40 pin connectors	
Common Configuration	Number of Commons	8
	Output Points per common	8 points
	Common Polarity	minus
Withstand Voltage	1500 Vac for 1 minute	
Over-current Protection	None (required externally)	
Current Consumption	250 mA (5 Vdc) or less	
Circuit Configuration		

2. Specifications

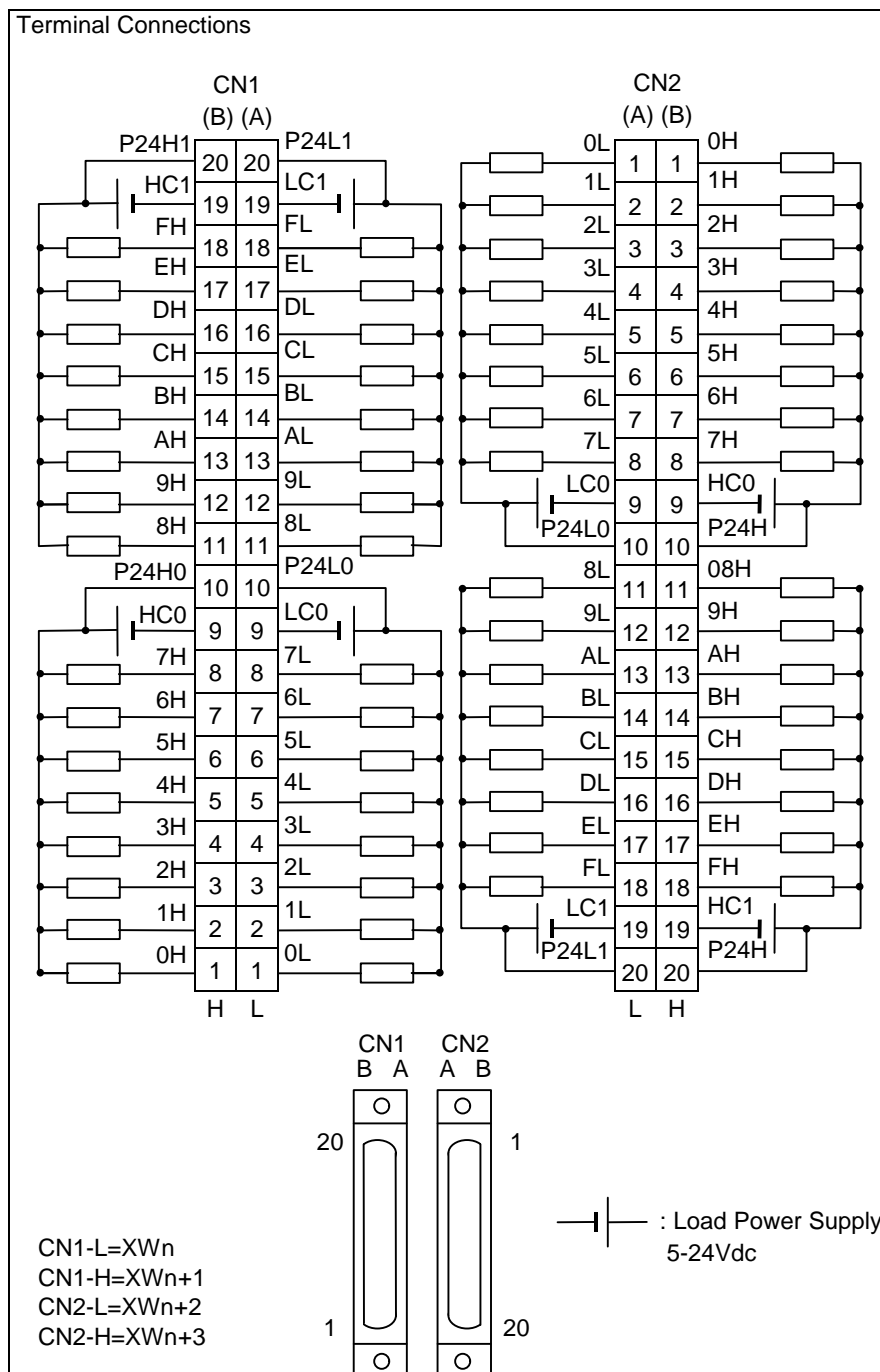

Note) Cable side connectors (soldering type) are attached as standard.

2. Specifications

- **16 points transistor output (current source)**

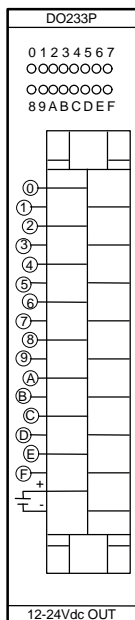

Item	DO233P (TDO233P*S)
Load Voltage	12 - 24 Vdc, +10/-5% (Internal current consumption 35 mA or less)
Output Current	1 A / point 1.2A / 4 points (4-element transistor array)
Output ON Resistance	1.5 Ω or less
Number of Output Points	16 points (single common, current sourcing)
ON Delay	1 ms or less
OFF Delay	1 ms or less
Leakage Current at OFF	0.1 mA or less
Withstand Voltage	1500 Vac for 1 minute
Over-current Protection	Built-in 5 A fuse (per common)
Current Consumption	60 mA (5 Vdc) or less

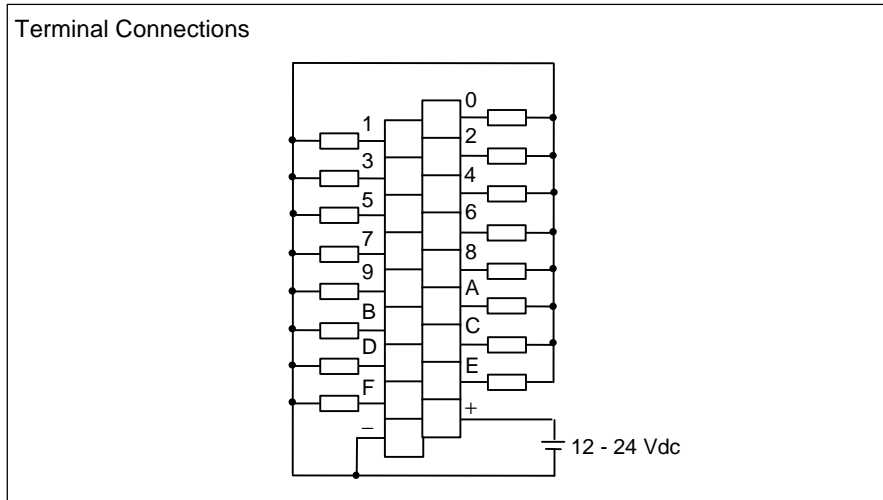
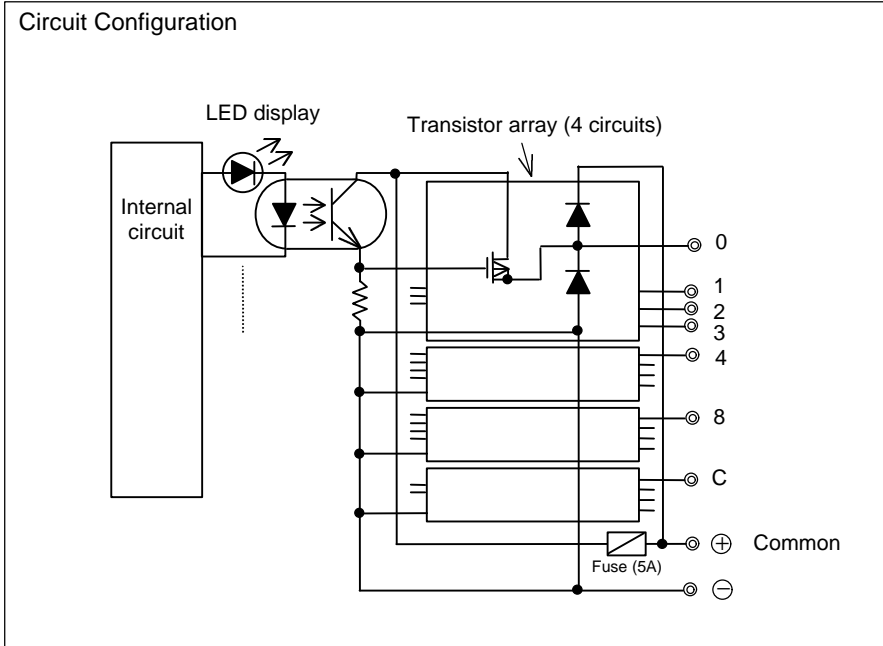

2. Specifications

- 12 points triac output

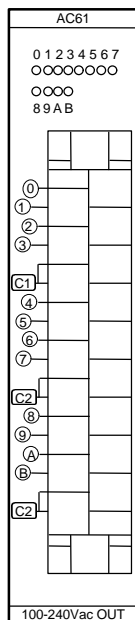

Item	AC61 (EX10*MAC61)
Load Voltage	100 - 240 Vac, +10/-5 % (50/60 Hz sine wave)
Output Current	0.5 A / point, 0.6 A (2-element SSR)
Voltage Drop at ON	1.5 V or less (0.3 A load)
Number of Output Points	12 points (4 points / common)
ON Delay	1 ms or less
OFF Delay	1/2 cycle of load power + 1 ms or less
Leakage Current at OFF	1.2 mA (100 Vac) or less, 3 mA (240 Vac) or less
Withstand Voltage	1500 Vac for 1 minute
Over-current Protection	Built-in 2 A fuse (per common)
Current Consumption	300 mA (5 Vdc) or less

Circuit Configuration

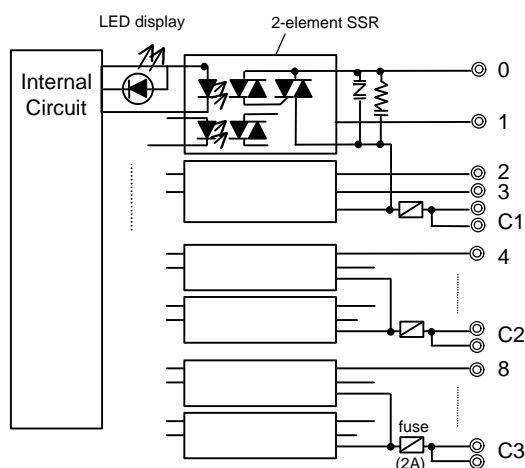

Terminal Connections

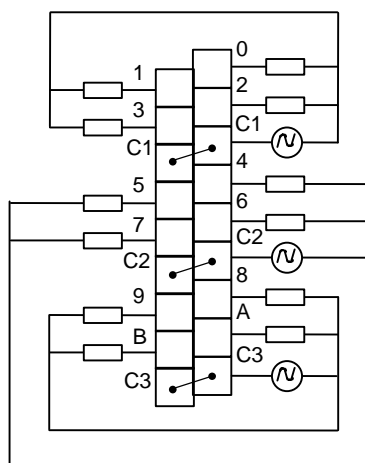

2. Specifications

- **4 channels analog input (8-bit)**

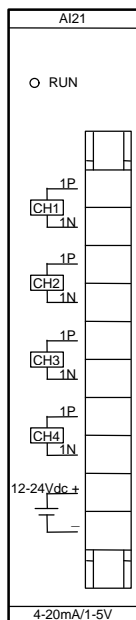

The AI21 type is set to 4 - 20 mA at the factory. For 1 - 5 V input, set J1 - J4 to V side.

Item	A121 (EX10*MA121)	A131 (EX10*MA131)
Input Range	1 - 5 V or 4 - 20 mA	0 - 10 V
Input Impedance	1 - 5 V: 500 kΩ or more 4 - 20 mA: 250 Ω	500 kΩ or more
Number of Input Points	4 channels (N common)	4 channels (N common)
Resolution	8-bit (1/250)	8-bit (1/250)
Overall Accuracy	±1 % (FS)	±1 % (FS)
Conversion Cycle	Approx. 1 ms	Approx. 1 ms
Wire Breakage Detection	Yes, for 4-20mA	No
External Power Failure Detection	Yes	Yes
Withstand Voltage	1500 Vac for 1 minute	1500 Vac for 1 minute
Current Consumption	50 mA (5 Vdc) or less	50 mA (5 Vdc) or less
External Power Required	12 - 24 Vdc, ±10 % 50 mA	12 - 24 Vdc, ±10 % 50 mA

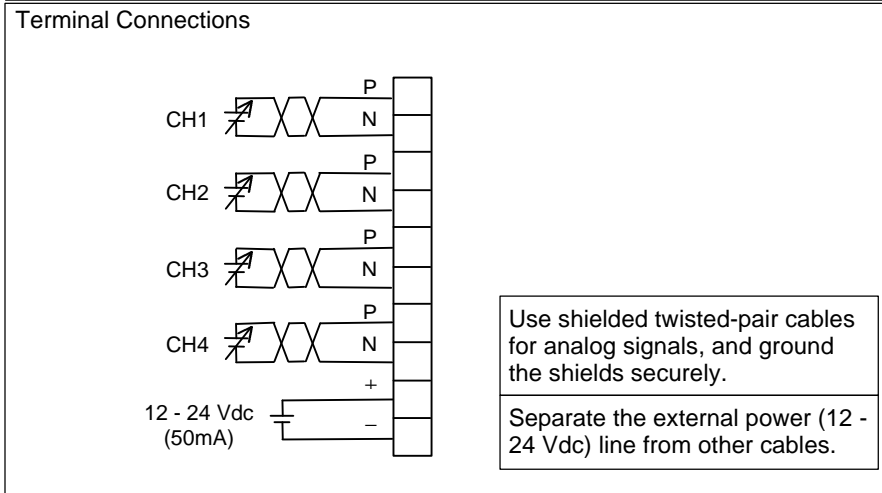
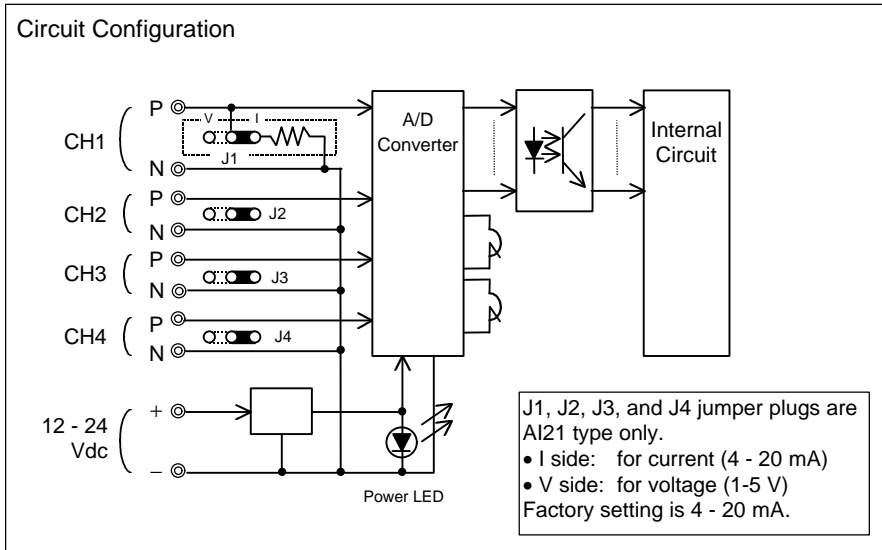

2. Specifications

A/D Conversion

Digital Value

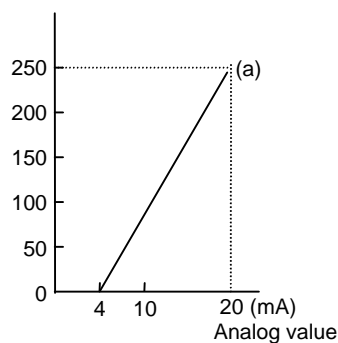

Digital Value

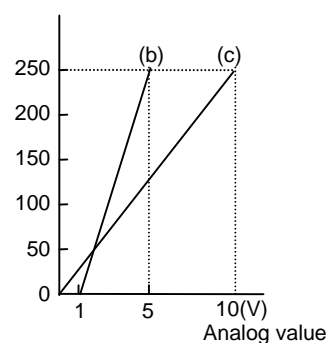

(a) 4 - 20 mA range: $D = 15.625 \times A - 62.5$

(b) 1 - 5 V range: $D = 62.5 \times A - 62.5$

(c) 0 - 10 V range: $D = 25 \times A$

$\left[\begin{array}{l} D = \text{Digital Value} \\ A = \text{Analog Value} \end{array} \right]$

Data Format

	F	E	D	C	B	A	9	8	7	6	5	4	3	2	1	0
XW	B	*	*	*	*	*	*	*	D	D	D	D	D	D	D	D

D: Data bit (8 bits)
0 to 250 (H00 to HFA)

B: Error bit
0 = Normal
1 = Error with all D is 0, analog input line is open. (4 - 20 mA only)
with all D is 1, external power (12 - 24 Vdc) is not normal.

*: Always 0

Register assignment

	F	0
XWn	CH1	
XWn+1	CH2	
XWn+2	CH3	
XWn+3	CH4	

Note)

In the voltage input mode, if the input terminals (P and N) are open, the input data is not 0. It is recommended to short the input terminals for unused input.

2. Specifications

- **4 channels analog input (12-bit)**

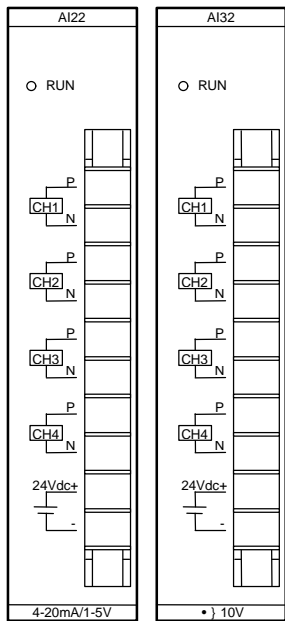

The AI22 type is set to 4-20 mA input at the factory.
For 1-5 V input, set J11 - J14 to V side.

Item	AI22 (EX10*MA122)	AI32 (EX10*MA132)
Input Range	1 - 5 V or 4 - 20 mA	-10 to +10V
Input Impedance	1 - 5 V: 1 MΩ or more 4 - 20 mA: 250 Ω	1 MΩ or more
Number of Input Points	4 channels (N common)	4 channels (N common)
Resolution	12-bit (1/4000)	12-bit (1/4000)
Overall Accuracy	±0.5 % (FS) / 25°C ±1 % (FS) / 0 - 55°C	±0.5 % (FS) / 25°C ±1 % (FS) / 0 - 55°C
Conversion Cycle	Approx. 9.6 ms/4 channels	Approx. 9.6 ms/4 channels
Wire Breakage Detection	Yes, for 4 - 20 mA	No
External Power Failure Detection	Yes	No
Withstand Voltage	1500 Vac for 1 minute	1500 Vac for 1 minute
Current Consumption	50 mA (5 Vdc) or less	50 mA (5 Vdc) or less
External Power Required	24 Vdc, ±10% - 50 mA	24 Vdc, ±10% - 50 mA

Circuit Configuration

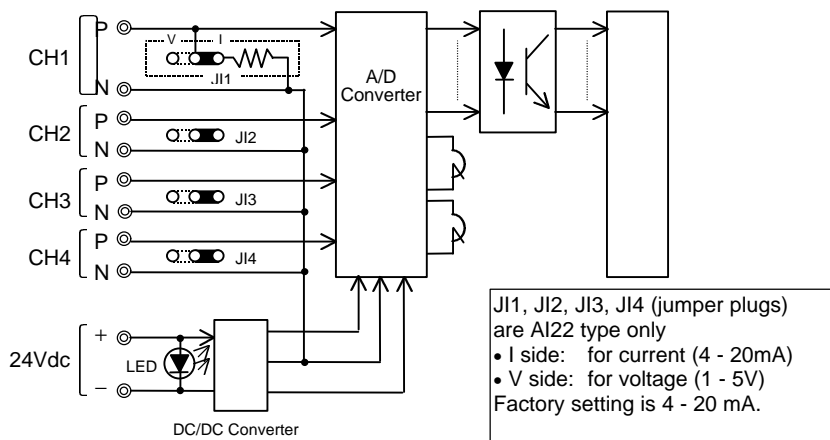

Terminal Connections

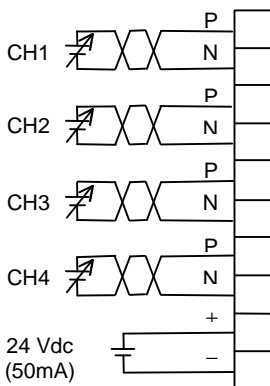

Use shielded twisted-pair cables for analog signals, and ground the shields securely.

Separate the external power (24 Vdc) line from other cables.

2. Specifications

A/D Conversion

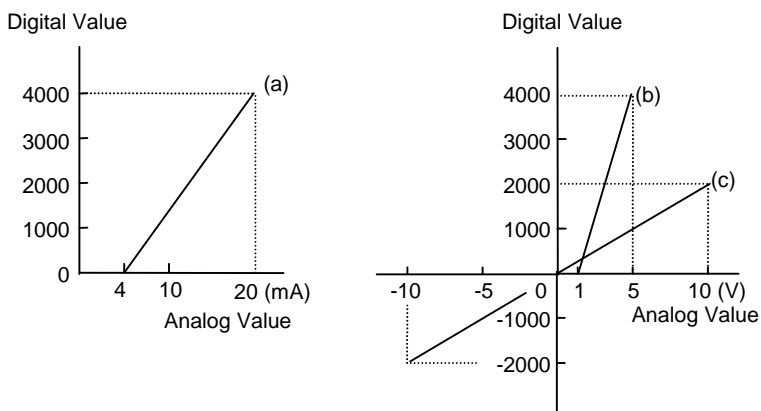

- (a) 4 - 20 mA range: $D = 250 \times A - 1000$
 (b) 1 - 5 V range: $D = 1000 \times A - 1000$
 (c) ± 10 V range: $D = 200 \times A$

$\left[\begin{array}{l} D = \text{Digital value} \\ A = \text{Analog value} \end{array} \right]$

Data Format

• 4-20mA/1-5V

	F	E	D	C	B	A	9	8	7	6	5	4	3	2	1	0
XW	B	*	*	*	D	D	D	D	D	D	D	D	D	D	D	D

D: Data bit (12 bits)

0 to 4000 (H0000 to H0FA0)

B: Error bit

0 = Normal

1 = Error (analog input line is open or external power is not normal)

*: Always 0

• ± 10 V

	F	E	D	C	B	A	9	8	7	6	5	4	3	2	1	0
XW	S	S	S	S	S	D	D	D	D	D	D	D	D	D	D	D

S: Sign bit

0 = Positive

1 = Negative

D: Data bit (11 bits)

-2000 to 2000 (HF830 to H07D0)

2' s complement if negative

Note)

In the voltage input mode, if the input terminals (P and N) are open, the input data is not 0. It is recommended to short the input terminals for unused input.

2. Specifications

- 2 channels analog output (8-bit)

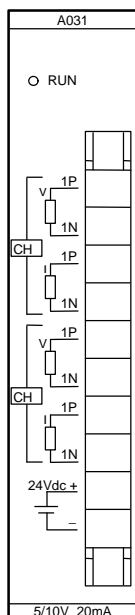

The AO31 type is set to 1 - 5 V, 4 - 20 mA setting at the factory. Refer to the circuit configuration for 0 - 10 V jumper setting.

Item	AO31 (EX10*MA031)
Output Range	0 - 10 V, 1 - 5 V, or 4 - 20 mA
Load Impedance	5 V full-scale terminal: 5 k Ω or more 10 V full scale terminal: 10 k Ω or more 20 mA full-scale terminal: 600 Ω or less
Number of Output Points	2 channels (N side common)
Resolution	8-bit (1/250)
Overall Accuracy	± 1 % (FS)
Conversion Cycle	Approx. 1 ms
External Power Failure Detection	No
Withstand Voltage	1500 Vac for 1 minute
Current Consumption	70 mA (5 Vdc) or less
External Power Required	24 Vdc, ± 10 % - 90 mA

Circuit Configuration

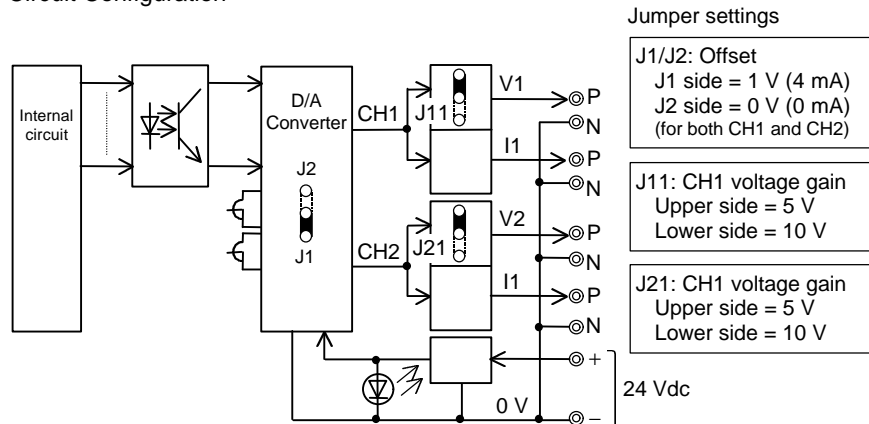

Terminal Connections

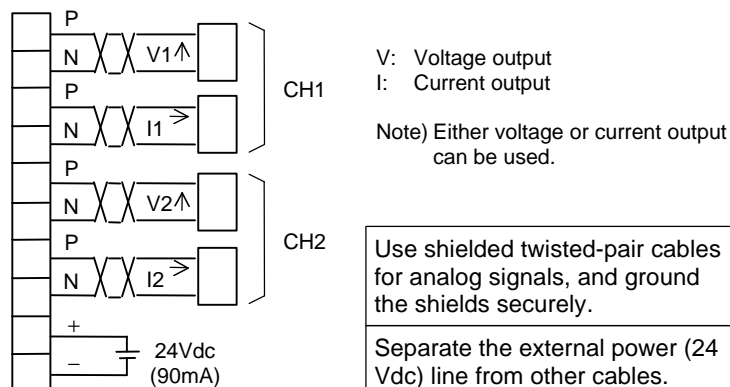

2. Specifications

D/A Conversion

Analog Value (mA)

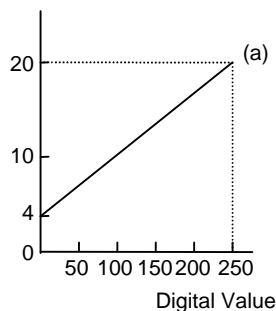

Analog Value (V)

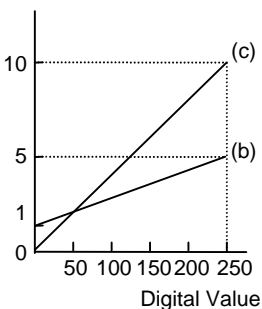

- (a) 4 - 20 mA range: $A = 0.064 \times D + 4$ (mA)
 (b) 1 - 5 V range: $A = 0.016 \times D + 1$ (V)
 (c) 0 - 10 V range: $A = 0.04 \times D$ (V)

$\left[\begin{array}{l} A = \text{Analog value} \\ D = \text{Digital value} \end{array} \right]$

Data Format (2 output registers (YW) are assigned)

	F	E	D	C	B	A	9	8	7	6	5	4	3	2	1	0
YW	*	*	*	*	*	*	*	*	D	D	D	D	D	D	D	D

D: Data bit (8 bits)
0 to 250 (H00 to HFA)

*: Invalid (does not affect D/A conversion)

Register assignment

	F	0
YW _n	CH1	
YW _{n+1}	CH2	

Note) If the direct I/O instruction (FUN 235) is used for this module, two registers (both channels) should be specified.

2. Specifications

- 2 channels analog output (12-bit)

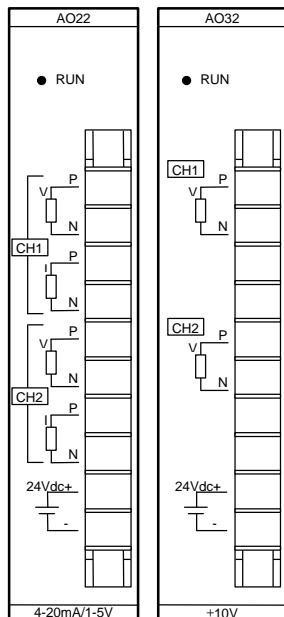

Item	AO22 (EX10*MAO22)	AO32 (EX10*MAO32)
Output Range	1 - 5 V or 4 - 20 mA	-10 to +10V
Load Impedance	1 - 5 V: 5 kΩ or more 4 - 20 mA: 600 Ω or less	5 kΩ or more
Number of Output Points	2 channels (N side common)	2 channels (N side common)
Resolution	12-bit (1/4000)	12-bit (1/4000)
Overall Accuracy	±0.5 % (FS) / 25°C ±1 % (FS) / 0~55°C	±0.5 % (FS) / 25°C ±1 % (FS) / 0~55°C
Conversion Cycle	Approx. 1 ms	Approx. 1 ms
External Power Failure Detection	No	No
Withstand Voltage	1500 Vac for 1 minute	1500 Vac for 1 minute
Current Consumption	170 mA (5 Vdc) or less	170 mA (5 Vdc) or less
External Power Required	24 Vdc, ±10% - 90 mA	24 Vdc, ±10% - 90 mA

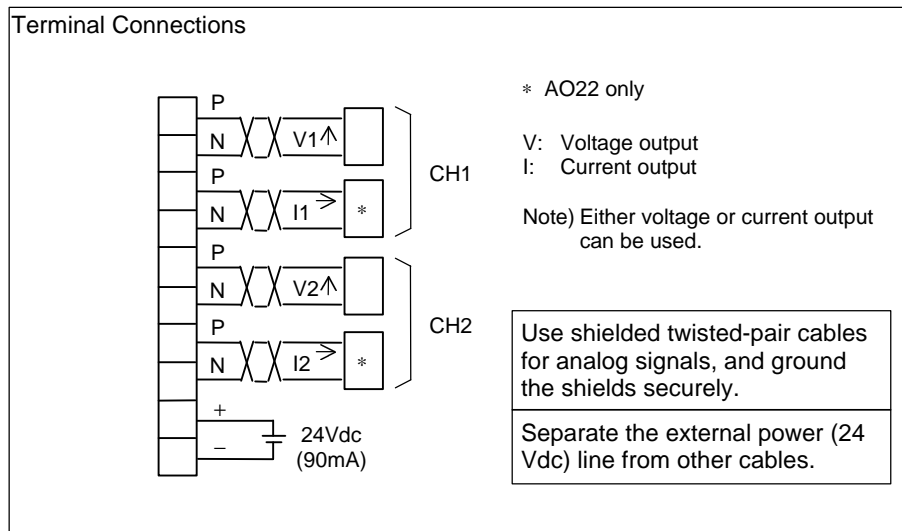
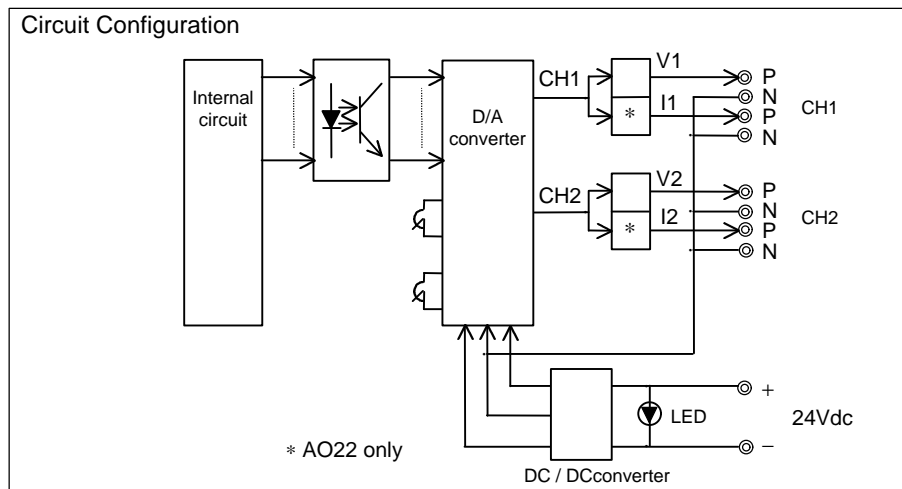

2. Specifications

D/A Conversion

Analog Value (mA)

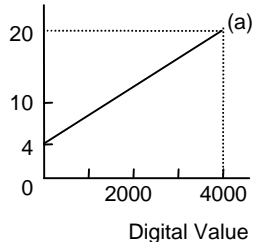

Analog Value (V)

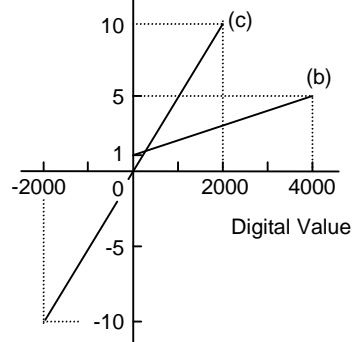

(a) 4 - 20 mA range: $A = 0.004 \times D + 4$ (mA)

(b) 1 - 5 V range: $A = 0.001 \times D + 1$ (V)

(c) ± 10 V range: $A = 0.005 \times D$ (V)

[A = Analog value
D = Digital value]

Data Format (2 output registers (YW) are assigned)

- 4 - 20 mA / 1 - 5 V

	F	E	D	C	B	A	9	8	7	6	5	4	3	2	1	0
YW	*	*	*	*	D	D	D	D	D	D	D	D	D	D	D	D

D: Data bit (12 bits)

0 to 4000 (H0000 to H0FA0)

*: Invalid (does not affect D/A conversion)

- ± 10 V

	F	E	D	C	B	A	9	8	7	6	5	4	3	2	1	0
YW	*	*	*	*	S	D	D	D	D	D	D	D	D	D	D	D

S: Sign bit

0 = Positive

1 = Negative

D: Data bit (11 bits)

-2000 to 2000 (HF830 to H07D0)

2' s complement if negative

Note) If the direct I/O instruction (FUN 235) is used for this module, two registers (both channels) should be specified.

2. Specifications

- 1 channel pulse input

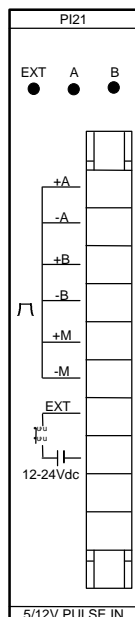

Item	PI21 (EX10*MP121)	
Input Voltage	A, B, M	12 V, +10/-20 % (12 V setting), 5 V, +10/-20 % (5V setting)
	EXT	12 - 24 Vdc, +10/-15 %
Minimum ON Voltage	A, B, M	9 V (12 V setting), 3.5 V (5 V setting)
	EXT	9.6 V
Maximum OFF Voltage	A, B, M	2 V (12 V setting), 1 V (5 V setting)
	EXT	3.6 V
Input Current	A, B, M	12 V - 7.5 mA (12 V setting), 5V - 10 mA (5V setting)
	EXT	24 V - 10 mA, 12 V - 5 mA
Number of Input Points	1 channel (phase A, B, M and EXT)	
Pulse Counting Speed	100 kpps (max.) (pulse-width 4 μ s or more)	
Counter Configuration	24-bit binary	
Pulse Input Mode	Quadrature	Phase A, B (90 degree phase shift), up/down
	Up / down	Phase A: count up / phase B: count down
Counter Operation Mode	Normal	Always count enable
Counter Reset	Hold	Both M and EXT are ON: Count enable Either M or EXT is OFF: Count stop (count value held)
		Count value is reset to 0 at the moment when both M and EXT are ON
EXT Input ON/OFF Delay	5 ms or less	
Withstand Voltage	1500 Vac for 1 minute	
Current Consumption	80 mA (5 Vdc) or less	

The input voltage of A, B and M are set to 12 V, and the counter mode is set to quadrature normal count mode at the factory.

Circuit Configuration

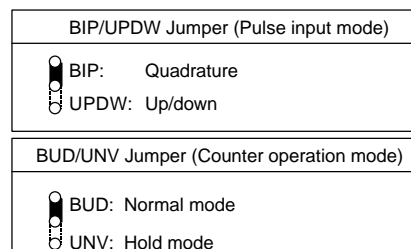
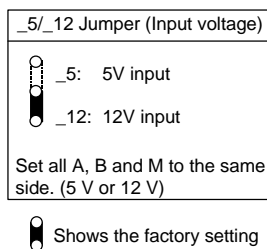
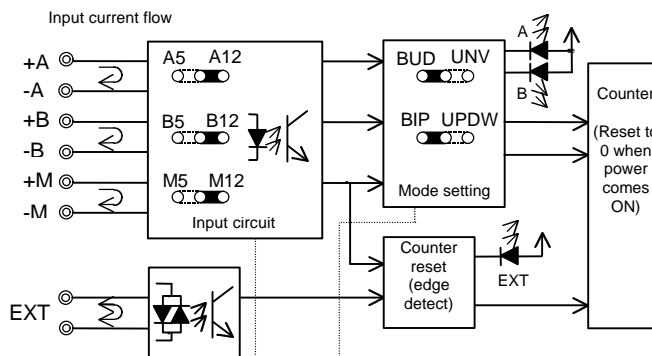

2. Specifications

Terminal Connections

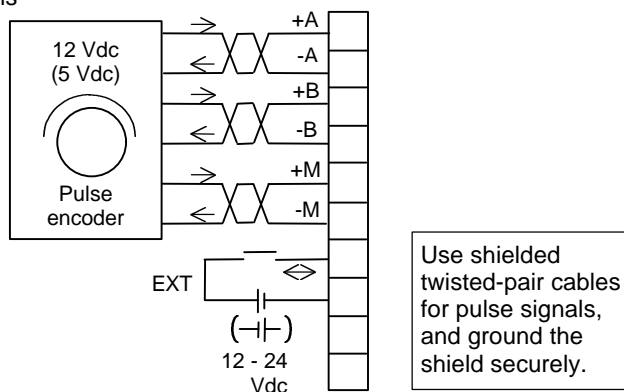

Wiring Example

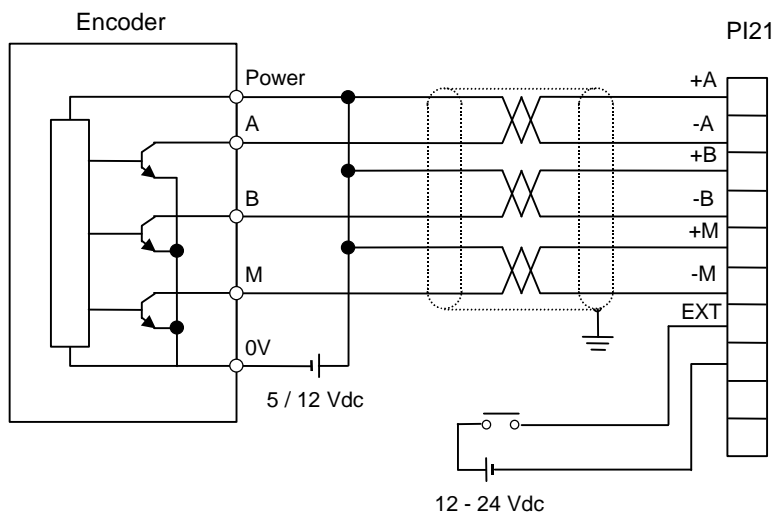

Data Format

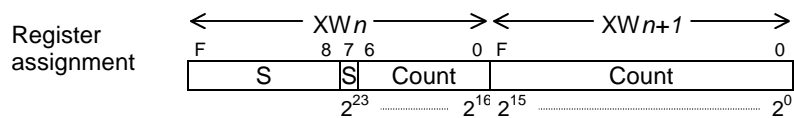

24-bit counter: Data range = -8388608 to 8388609
(HFF800000 to H007FFFFF)

The counter works as a ring counter. If upper 8 bits of XW n is masked, the count data range is 0 to 16777215.

Note) The double-word register arrangement of the PI21 and that of the T1 are different. In the T1 user program, exchange the upper and lower words as follows.

```
┌─[ XW00 MOV D0101 ]─┐┌─[ XW01 MOV D0100 ]─┐
```

In this example, the PI21 is allocated to XW00 and XW01, and the count value is stored in double-word register D0101·D0100.

2. Specifications

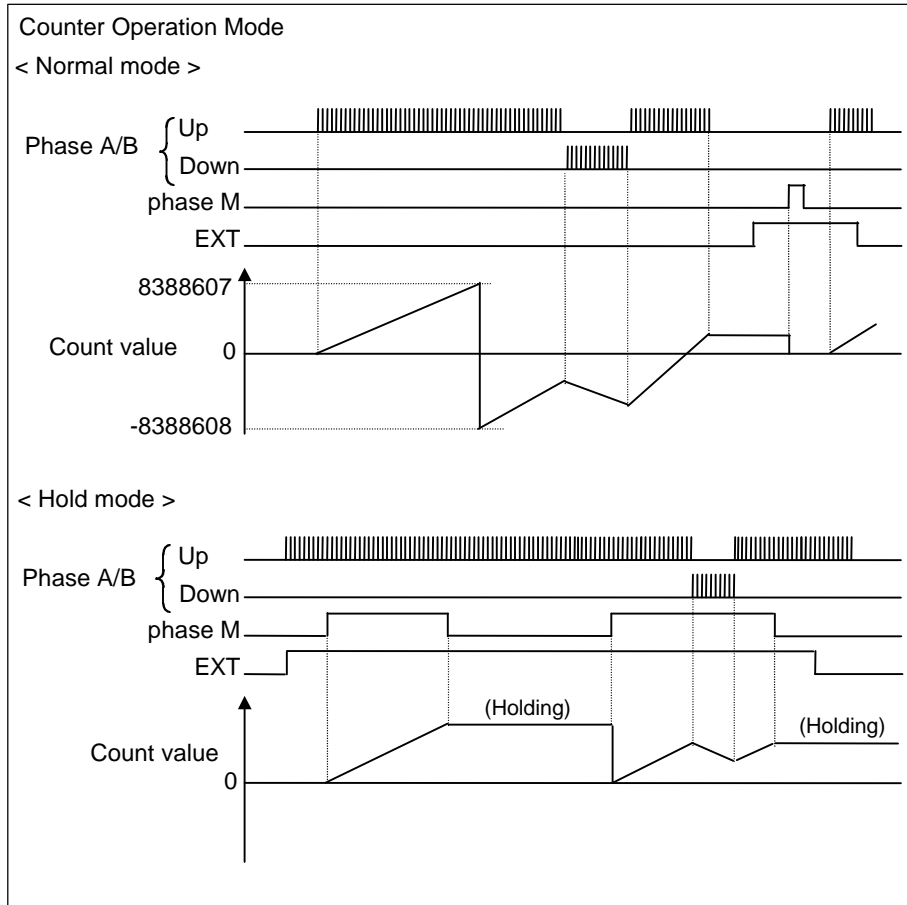
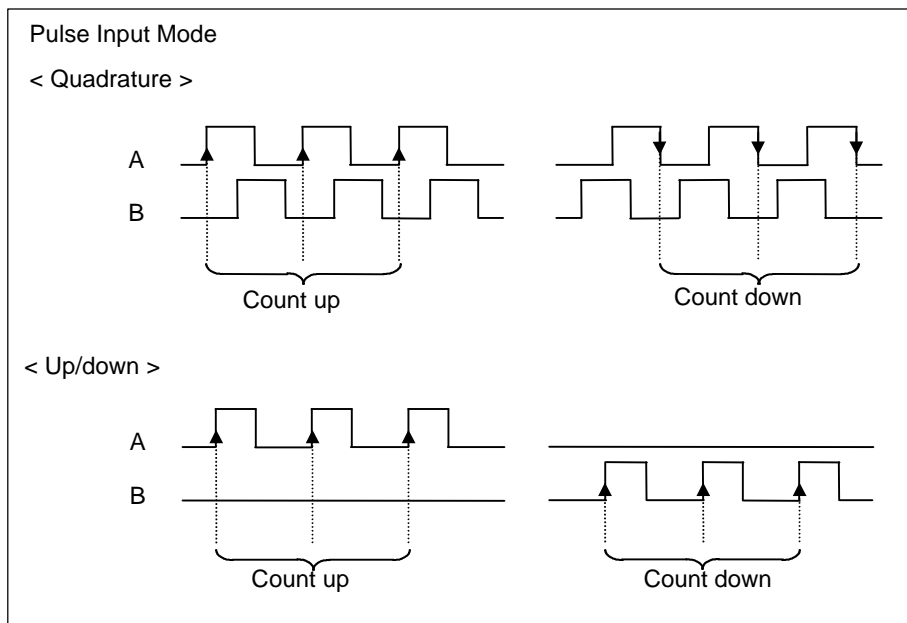

Note) If the direct I/O instruction (FUN 235) is used for this module, two registers (both upper and lower words) should be specified.

2. Specifications

- 1 axis position control

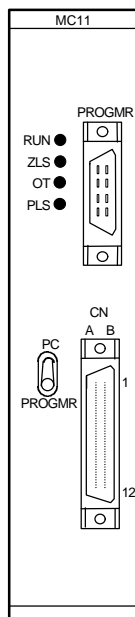

Item		MC11 (EX10*MMC11)	
Number of Control Axes		1 axis	
Control Units		Pulse, inch, mm, etc.	
Control Range		±999,999 (units)	
Point Data Capacity		64 points	
Maximum Speed		200 kpps	
Operation Speed		Zero return speed, Maximum speed, Minimum speed	
Acceleration / Deceleration System		Automatic trapezoidal / triangular system	
Acceleration / Deceleration Time		0 to 26 s	
Backlash Compensation		0 to 1000 pulses	
Zero Position Offset		±999,999 units	
Dwell Time		0 to 99 s	
I/O Allocation Type		X+Y 4 W (2 XW and 2 YW registers)	
Parameter Storage		EEPROM	
Input	Input Voltage	12 - 24 Vdc (Z-phase: 5 V or 12 - 24 V)	
	Input Current	10 mA (at 24 Vdc)	
	ON / OFF Voltage	9.6 V / 3.2 V	
	ON / OFF Delay	5 ms (Z-phase: 1 ms)	
Output	Pulse Output	Mode (Switch setting)	(1) CW or CCW, Error counter clear (2) Pulse + Direction, Error counter clear
		Output Method	Open collector (5 - 24 Vdc, 50mA)
		ON / OFF Delay	2 μs
	RUN Output	Output Method	Open collector (5 - 24 Vdc, 50mA)
		Operation	ON during normal operation
Current Consumption	Internal	200 mA - 5 Vdc 400 mA - 5 Vdc (when HP100 connected)	
	External	100 mA - 12 - 24 Vdc	

Connector Pin Arrangement

	A	B	
RUN output (0V)	1	1	RUN output (5-24Vdc)
CW or Pulse output (0V)	2	2	CW or Pulse output (5-24Vdc)
CCW or Direction output (0V)	3	3	CCW or Direction output (5-24Vdc)
Error counter clear output (0V)	4	4	Error counter clear output (5-24Vdc)
Z-phase input (0V)	5	5	Z-phase input (5Vdc)
Z-phase input (0V)	6	6	Z-phase input (12-24Vdc)
Zero position switch input (-/+)	7	7	Zero position switch input (+/-)
HOLD input (-/+)	8	8	HOLD input (+/-)
Emergency stop input (-/+)	9	9	Emergency stop input (+/-)
CW over-travel limit input (-/+)	10	10	CW over-travel limit input (+/-)
CCW over-travel limit input (-/+)	11	11	CCW over-travel limit input (+/-)
Power input (0V)	12	12	Power input (12-24Vdc)

Note) Cable side connector (soldering type) is attached as standard.

2. Specifications

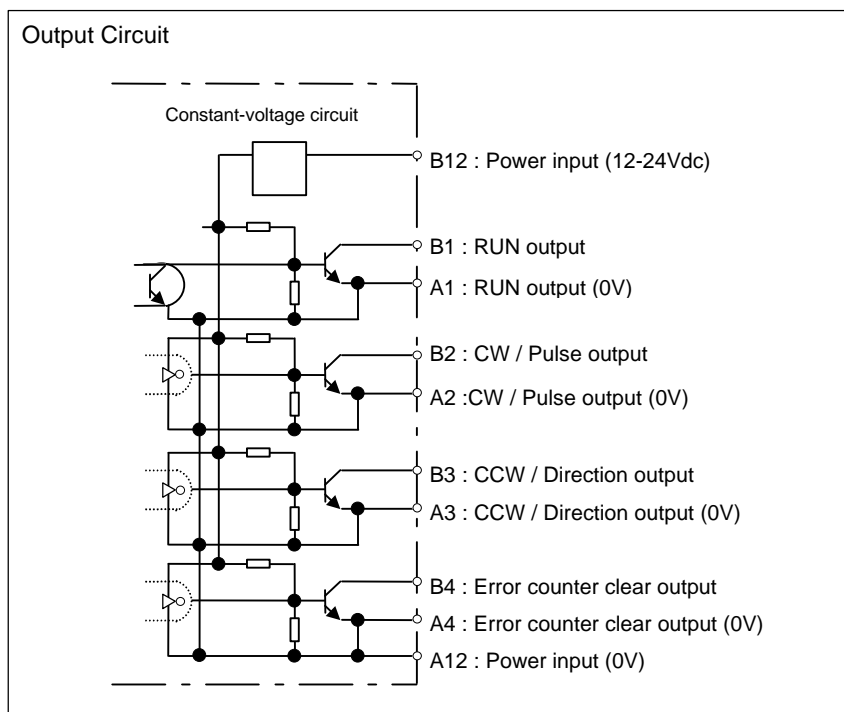
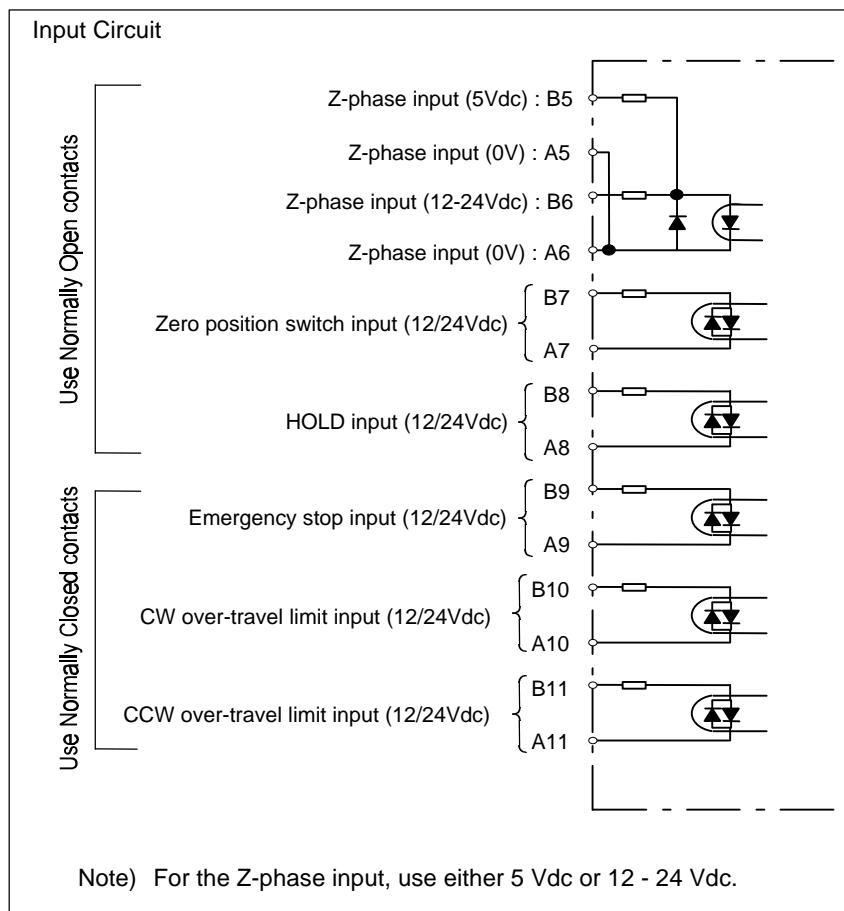

2. Specifications

• Communication interface

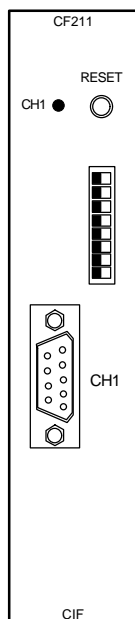

Item	CF211 (TCF211**S)
Module Type	Serial communication interface module
I/O Allocation Type	i X+Y 4W (2 input XW and 2 output YW registers assigned)
Buffer Memory Capacity	160 words × 2 (accessed from T1/T1S by READ/WRITE instruction)
Transmission Interface	RS-232C, 1 channel
Transmission Mode	Full-duplex
Synchronizing	Start-stop system (asynchronous)
Frame Format	Start bit: 1 bit Data bits: 7 or 8 bits Parity: odd/even/none Stop bit: 1 or 2 bits (Total 10 or 11 bits)
Transmission Speed	300, 600, 1200, 2400, 4800, 9600 or 19200 bps
Transmission Code	ASCII
Message Length	Max. 320 bytes
Interface Connector	Dsub-9-pin female connector
Display	1 LED display, lit when transmitting/receiving data
Isolation	None (between RS-232C port and internal logic)
Current Consumption	550 mA (5 Vdc) or less
Circuit Configuration	
Serial Interface Connection	
	Note) DTR is ON while power to the T1/T1S is ON.

Note) Refer to the CF211 manual for details.

Section 3

Installation

- 3.1 Mounting the option card, 60*
- 3.2 Connecting the expansion unit, 62*
- 3.3 Connecting the expansion rack, 63*
- 3.4 Mounting the I/O module, 64*

3. Installation

3.1 Mounting the option card

! CAUTION

- Turn off power to the T1/T1S before removing or mounting the option card. Failure to do so can cause electrical shock or damage to the product.
- Do not touch electronic components on the printed circuit board of the option card. It may cause damage to the product.
- Use attached screw (puller) for removing the option card. Do not pull I/O cable for removing the option card. It can cause unsafe situation because of cable disconnection.

- (1) Remove the option card slot cover provided on the right side of the T1-40(S) as follows.

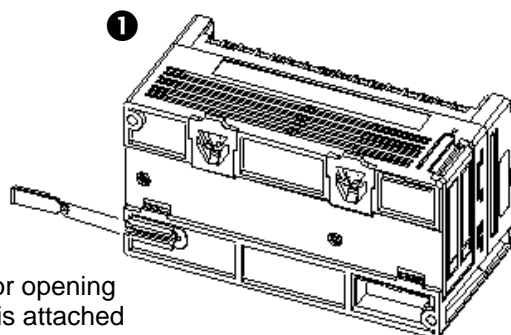

The tool for opening the cover is attached on the back of the unit. Remove the tool from the unit.

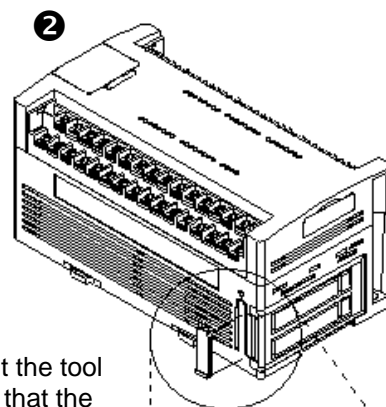

Put the tool so that the marks Δ on the tool and the unit are aligned.

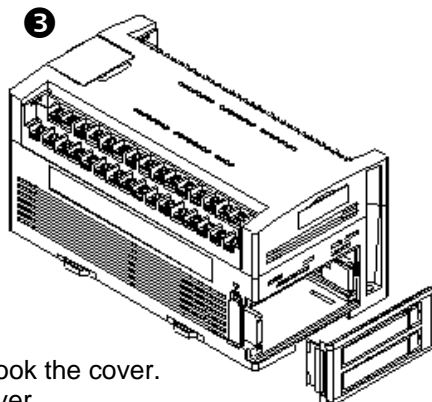

Push the tool to unhook the cover. Then remove the cover.

3. Installation

- (2) Insert the option card into the upper or lower slot.

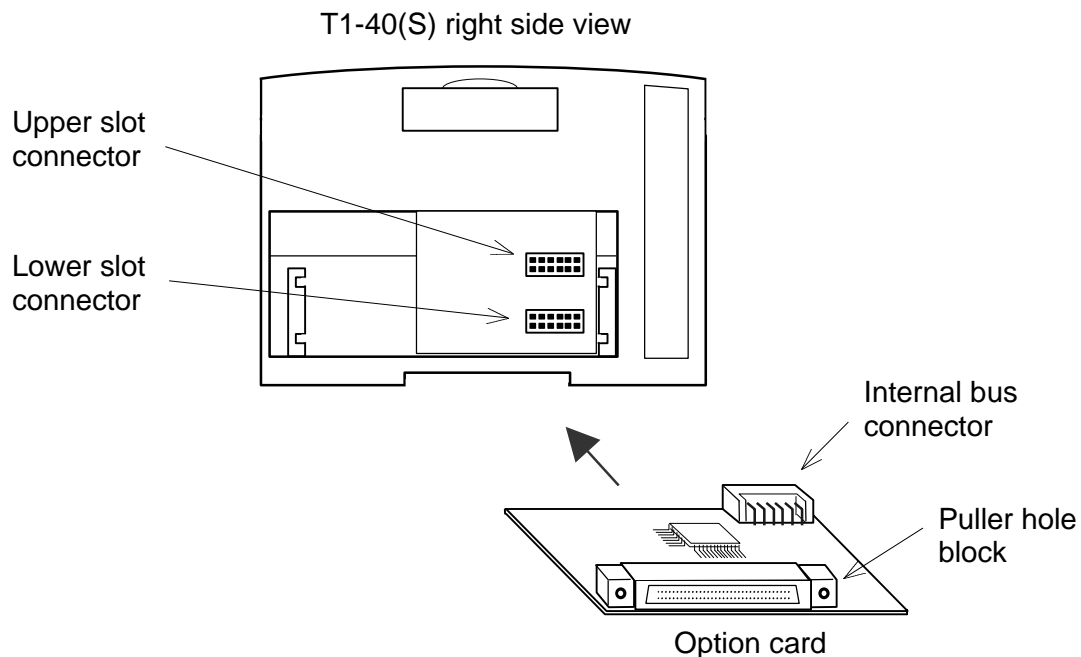

- (3) Push the puller hole block of the option card until it reaches the end. When the internal bus connector is inserted correctly, it will make a click.
- (4) Cut off the window of the option card slot cover with clippers, and fix the cover to the T1-40(S) to lock the option card.

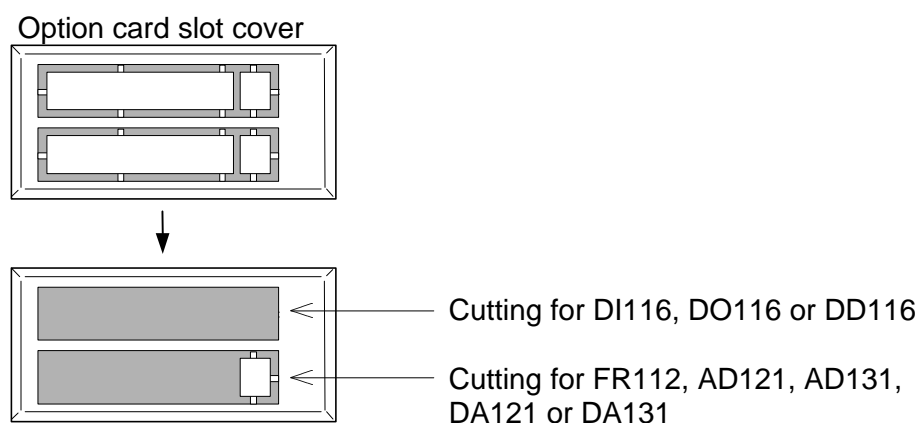

- (5) When you remove the option card, use the attached screw (puller). Fix the screw (puller) to the puller hole block of the option card, and pull the screw (puller). Do not pull I/O cable to remove the option card. It can cause cable disconnection.

3. Installation

3.2 Connecting the expansion unit

⚠ CAUTION

- Turn off power to the T1/T1S before connecting or removing the expansion unit. Failure to do so can cause electrical shock or damage to the product.
- Cover the unused expansion connector by attached protective cover to prevent short-circuit of the connector pins.

- (1) Remove the expansion connector cover provided on the right side of the T1-40(S) and the expansion unit.

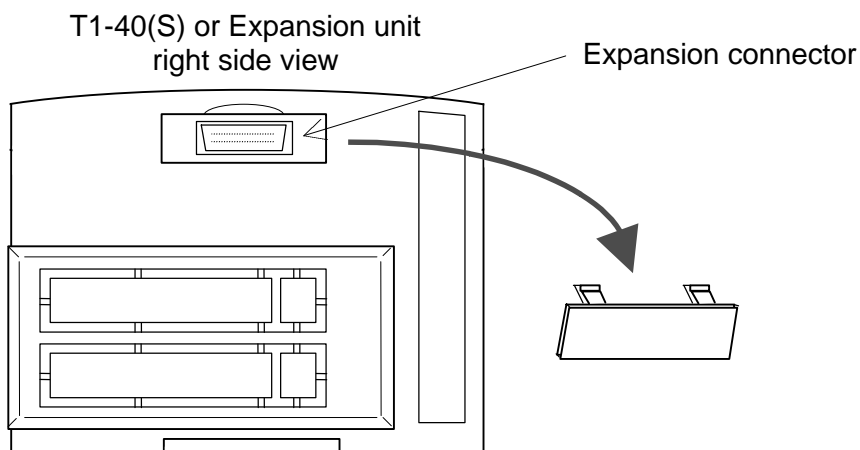

- (2) Connect the expansion unit with the T1-40(S) using the 0.5 m cable attached to the expansion unit.

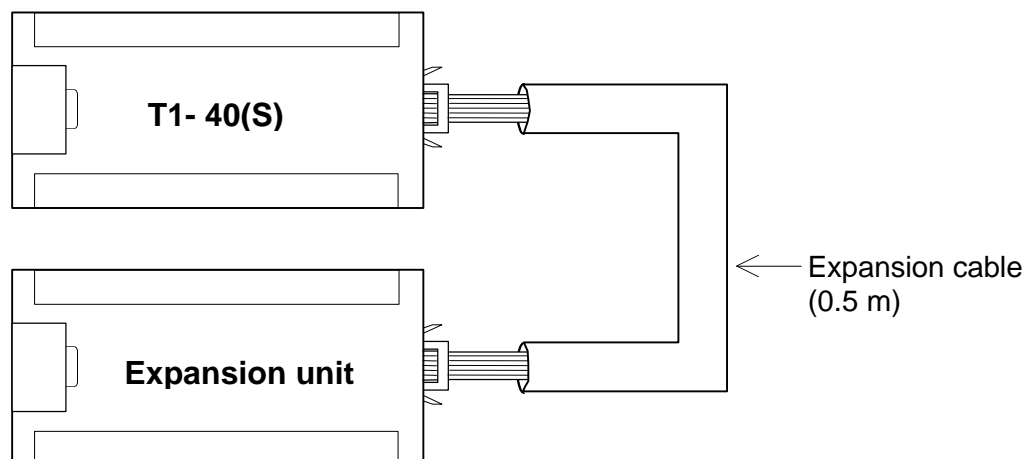

3. Installation

3.3 Connecting the expansion rack

! CAUTION

- Turn off power to the T1/T1S before connecting or removing the expansion rack. Failure to do so can cause electrical shock or damage to the product.
- Cover the unused expansion connector by attached protective cover to prevent short-circuit of the connector pins.

- (1) Remove the expansion connector cover provided on the right side of the T1-40(S).

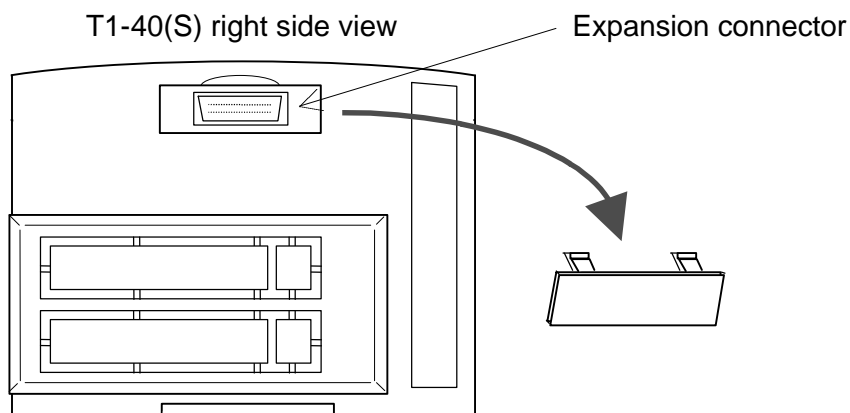

- (2) Connect the expansion rack with the T1-40(S) using the 0.15 m cable attached to the expansion rack.
On the expansion rack, two expansion connectors are provided on the both sides. However, either one connector can be used at a time. Normally, the left side connector is used.

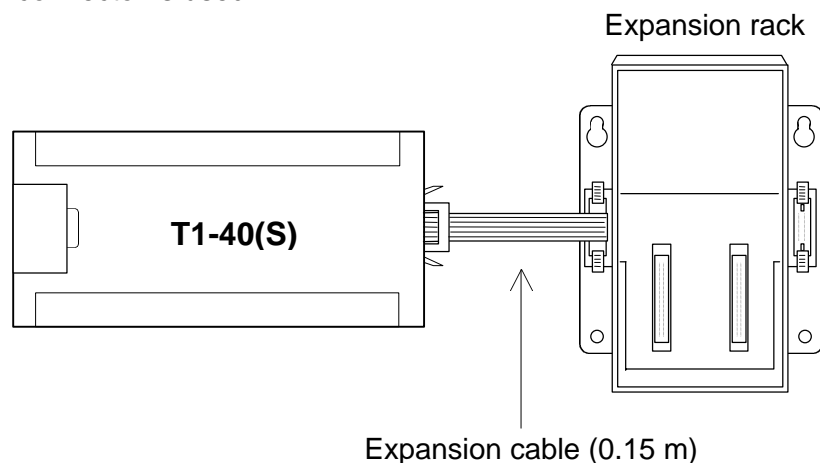

3. Installation

3.4 Mounting the I/O module

⚠ CAUTION

- Turn off power to the T1/T1S before removing or mounting the I/O module. Failure to do so can cause electrical shock or damage to the product.
- Do not touch electronic components on the printed circuit board of the I/O module. It may cause damage to the product.

- (1) Install I/O modules from the left slot, taking care to securely insert them into the slots of the expansion rack.
- (2) Insert the I/O module fully until both the upper and lower hooks of the of the I/O module are locked in the expansion rack.

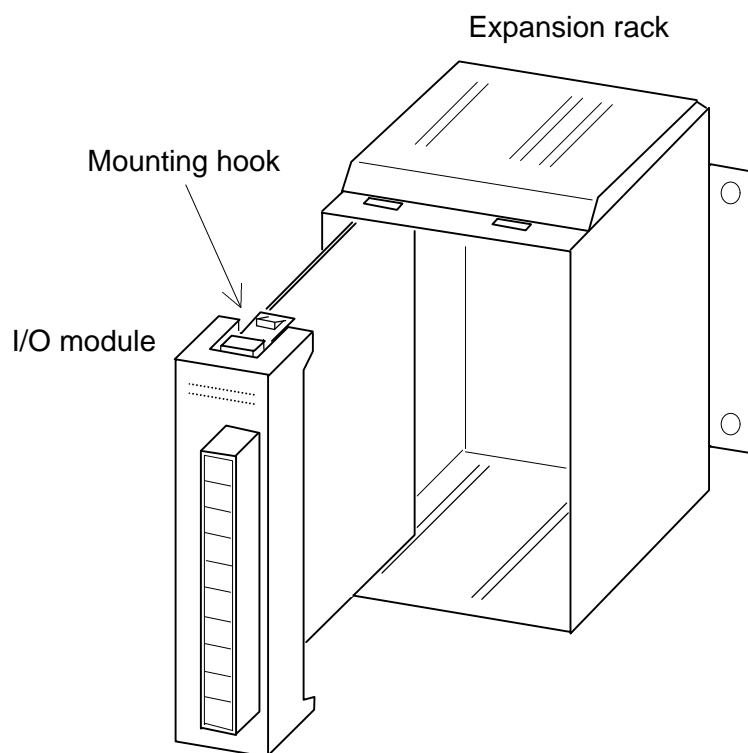

- (3) To remove the I/O module from the expansion rack, push both the upper and lower hook levers and pull the I/O module.

Section 4

I/O Allocation

- 4.1 I/O allocation overview, 66*
- 4.2 I/O allocation methods, 69*
- 4.3 Register assignment, 70*

4. I/O Allocation

4.1 I/O allocation overview

The I/O allocation is the operation to let the T1-40(S) to recognize the type and location of the option cards, the I/O modules and/or the expansion unit which are connected to the T1-40(S).

The T1-40(S) has the information called "I/O allocation table" in its memory. This "I/O allocation table" indicates what type of card/module/unit is connected on which mounting location. The contents of the I/O allocation table is as follows.

Slot	I/O type
PU	
0	X+Y 4W
1	
2	
3	
4	
5	
6	
7	

← PU slot must be blank
 ← Slot 0 is for T1/T1S basic unit
 ← Slots 1 to 3 are for option cards
 ← Slots 4 and 5 are for expansion unit
 ← Slots 4 to 7 are for I/O modules

The figure below shows the correspondence between I/O allocation "Slot" and hardware location.

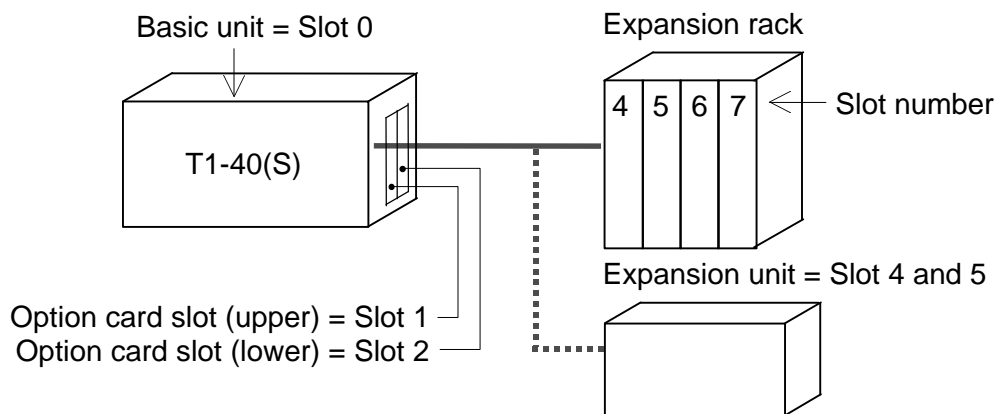

Note 1) Slot 3 is dedicated for the TOSLINE-F10 remote station card (FR112).
When the FR112 is used, it is allocated on the slot 3 regardless of physical mounting location (upper or lower slot).

Note 2) When the 2-slot expansion rack (BU152) is used, slots 6 and 7 cannot be used.

Note 3) The expansion unit occupies two slots (slots 4 and 5) by one unit.

Note 4) The expansion rack and the expansion unit cannot be connected at the same time.

4. I/O Allocation

The “I/O type” indicates the type of card/module and assigned number of I/O registers (XW/YW registers).

“X” means input, “Y” means output, and “X+Y” means input and output mixture types. And, for example, “4W” means 4 words of XW/YW registers are assigned.

The table below shows the “I/O type” of each card/module.

Option card / I/O module			I/O type
T1-40(S) basic unit			X+Y 4W
Option card	16 points DC input	DI116	X 1W
	16 points DC output	DO116	Y 1W
	8 points input/8 points output	DD116	X+Y 2W
	1 channel analog input (12-bit)	AD121	X 1W
		AD131	X 1W
	1 channel analog output (12-bit)	DA121	Y 1W
		DA131	Y 1W
TOSLINE-F10 remote station	FR112	TL-F ¹⁾	
Expansion unit	16 points DC input/16 points relay output	T1-EDR32	X 1W ²⁾ Y 1W
	16 points AC input/16 points relay output	T1-EAR32	X 1W ²⁾ Y 1W
I/O module	16 points DC/AC input	DI31	X 1W
	32 points DC input	DI32	X 2W
	64 points DC input	DI235	X 4W
	16 points AC input (100 - 120 Vac)	IN51	X 1W
	16 points AC input (200 - 240 Vac)	IN61	X 1W
	12 points relay output	RO61	Y 1W
	8 points isolated relay output	RO62	Y 1W
	16 points relay output	RO263	Y 1W
	16 points transistor output	DO31	Y 1W
	32 points transistor output	DO32	Y 2W
	64 points transistor output	DO235	Y 4W
	16 points transistor output (source)	DO233P	Y 1W
	12 points triac output	AC61	Y 1W
	4 channels analog input (8-bit)	AI21	X 4W
		AI31	X 4W
	4 channels analog input (12-bit)	AI22	X 4W
		AI32	X 4W
	2 channels analog output (8-bit)	AO31	Y 2W
	2 channels analog output (12-bit)	AO22	Y 2W
		AO32	Y 2W
	1 channel pulse input	PI21	X 2W
	1 axis position control	MC11	X+Y 4W
	Communication interface	CF211	iX+Y 4W ²⁾

4. I/O Allocation

- Note 1) The FR112 has the I/O type “TL-F”. No XW/YW register is assigned to the FR112. For the FR112, special registers SW34 and SW35 are assigned, instead of XW/YW registers. See section 5.
- Note 2) The expansion unit requires two consecutive slots (slots 4 and 5) for I/O allocation. The slot 4 is “X 1W”, and slot 5 is “Y 1W”.
- Note 3) The I/O type of the CF211 has a prefix “i”. This “i” prefix functions to inhibit batch I/O refresh for the module. To add the “i” prefix for this modules, the manual I/O allocation operation is required. See section 4.2.

4. I/O Allocation

4.2 I/O allocation method

The operation to create the I/O allocation table is called "I/O allocation".

When the T1-40(S) is used without connecting option card, I/O module nor expansion unit, the I/O allocation is not required. Because the I/O allocation table for basic unit is created automatically when the memory clear operation is performed.

However, when option cards, I/O modules, and/or expansion unit are used, or T1/T1S's user program is developed in off-line, the I/O allocation is necessary.

There are two methods for the I/O allocation.

Automatic I/O allocation:

When the automatic I/O allocation command is executed from the programmer, the T1-40(S) checks the hardware configuration, then creates the I/O allocation table. This method is useful when all the necessary hardware (option cards, I/O modules and/or expansion unit) is prepared.

Manual I/O allocation:

I/O type can be set onto the I/O allocation table slot by slot by the programmer. (Editing of the I/O allocation table)

This method is used when off-line programming is performed or special I/O type, such as "i" prefix or SP is used.

The table below shows the available I/O type by the manual I/O allocation.

Function type	Number of I/O registers assigned	Description	
X	01, 02, 04, 08, or 16	For input	
Y	01, 02, 04, 08, or 16	For output	
X+Y	02, 04, 08, or 16	For input and output mixture	
iX	01, 02, 04, 08, or 16	For input	Batch I/O refresh is not executed
iY	01, 02, 04, 08, or 16	For output	
iX+Y	02, 04, 08, or 16	For input and output mixture	
Blank	-	For vacant slot (no register is assigned)	
SP	01, 02, 04, 08, or 16	Used to assign YW registers for vacant slot	
TL-F	-	For TOSLINE-F10 (no I/O register is assigned)	

NOTE



- (1) Do not use the I/O type other than the listed above for the T1/T1S.
- (2) To run the T1/T1S, the I/O allocation table and physical I/O configuration must be matched.

4. I/O Allocation

4.3 Register assignment

Once the I/O allocation table is created, the T1-40(S)'s registers are assigned to the hardware (card/module/unit) according to the following rules.

- (1) Input register (XW) and output register (YW) have consecutive register addresses. That is, one address is for either XW or YW.
- (2) XW registers are assigned to the I/O type "X".
- (3) YW registers are assigned to the I/O type "Y".
- (4) XW and YW registers are assigned to the I/O type "X+Y". Leading half are XW and following half are YW.
- (5) I/O registers (XW/YW) are assigned sequentially from slot 0.
- (6) T1-40(S) basic unit has the I/O type "X+Y 4W". Therefore, four registers (XW00, XW01, YW02 and YW03) are assigned to the basic unit. YW03 is assigned internally.
- (7) No register is assigned to a vacant slot.
- (8) Specified number of YW registers are assigned internally to the I/O type "SP".
- (9) For "TL-F", special registers SW34 and SW35 are assigned.

The following pages show some examples of register assignment for some configuration.

4. I/O Allocation

Example 1 (Option card)

- Hardware configuration

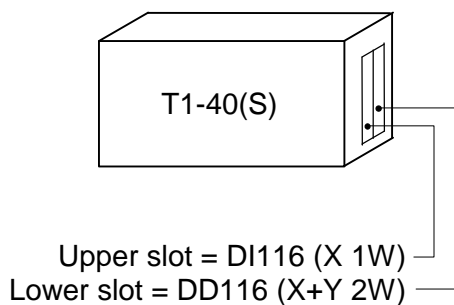

- I/O allocation table and register assignment

Slot	I/O type	Assigned register	Assigned device
PU			
0	X+Y 4W	XW00, XW01, YW02, YW03	X000 - X00F, X010 - X01F, Y020 - Y02F, Y030 - Y03F
1	X 1W	XW04	X040 - X04F
2	X+Y 2W	XW05, YW06	X050 - X05F, Y060 - Y06F
3			
4			
5			
6			
7			

- Hardware and register/device relation

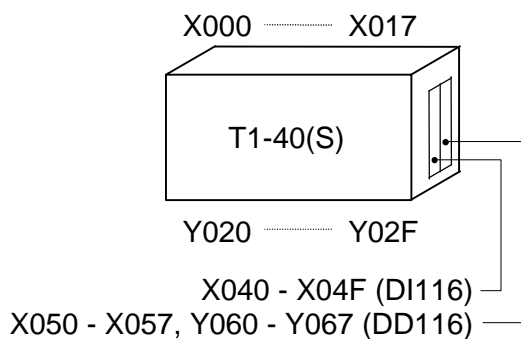

Note) X018 to X01F, Y030 to Y03F, X058 to X05F, and Y068 to Y06F are assigned internally.

4. I/O Allocation

Example 2 (Option card)

- Hardware configuration

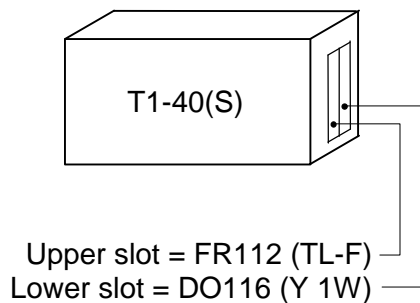

- I/O allocation table and register assignment

Slot	I/O type	Assigned register	Assigned device
PU			
0	X+Y 4W	XW00, XW01, YW02, YW03	X000 - X00F, X010 - X01F, Y020 - Y02F, Y030 - Y03F
1			
2	Y 1W	YW04	Y040 - Y04F
3	TL-F	SW34, SW35	S340 - S34F, S350 - S35F
4			
5			
6			
7			

- Hardware and register/device relation

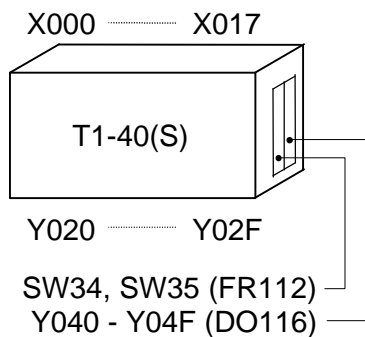

4. I/O Allocation

Example 3 (Expansion unit)

- Hardware configuration

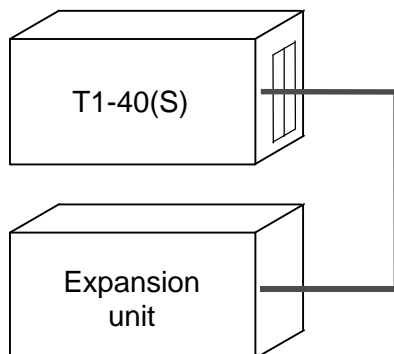

- I/O allocation table and register assignment

Slot	I/O type	Assigned register	Assigned device
PU			
0	X+Y 4W	XW00, XW01, YW02, YW03	X000 - X00F, X010 - X01F, Y020 - Y02F, Y030 - Y03F
1			
2			
3			
4	X 1W	XW04	X040 - X04F
5	Y 1W	YW05	Y050 - Y05F
6			
7			

- Hardware and register/device relation

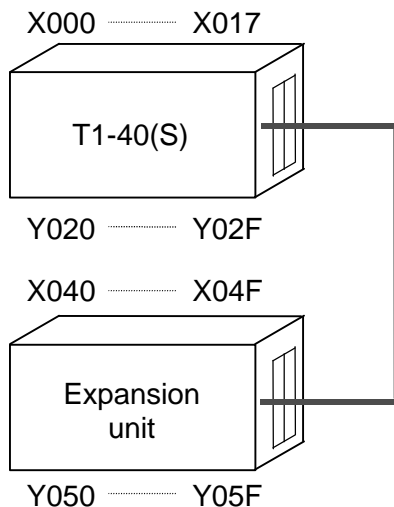

4. I/O Allocation

Example 4 (Option card and Expansion unit)

- Hardware configuration

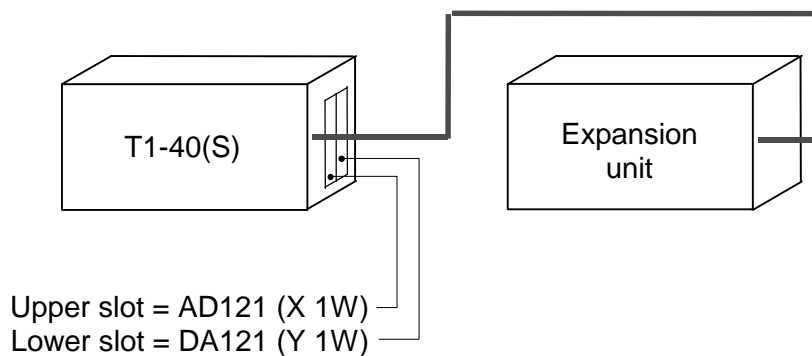

- I/O allocation table and register assignment

Slot	I/O type	Assigned register	Assigned device
PU			
0	X+Y 4W	XW00, XW01, YW02, YW03	X000 - X00F, X010 - X01F, Y020 - Y02F, Y030 - Y03F
1	X 1W	XW04	X040 - X04F
2	Y 1W	YW05	Y050 - Y05F
3			
4	X 1W	XW06	X060 - X06F
5	Y 1W	YW07	Y070 - Y07F
6			
7			

- Hardware and register/device relation

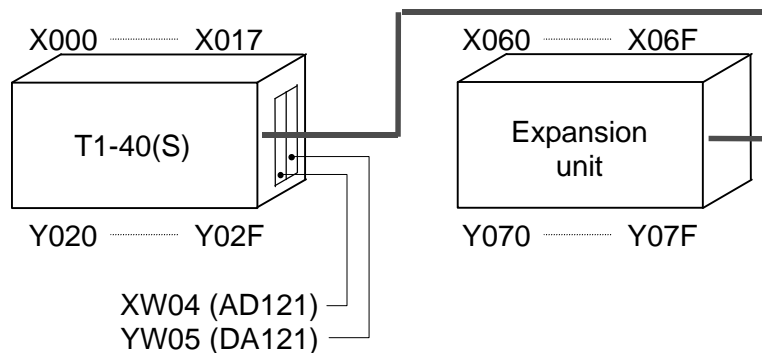

4. I/O Allocation

Example 5 (I/O module)

- Hardware configuration

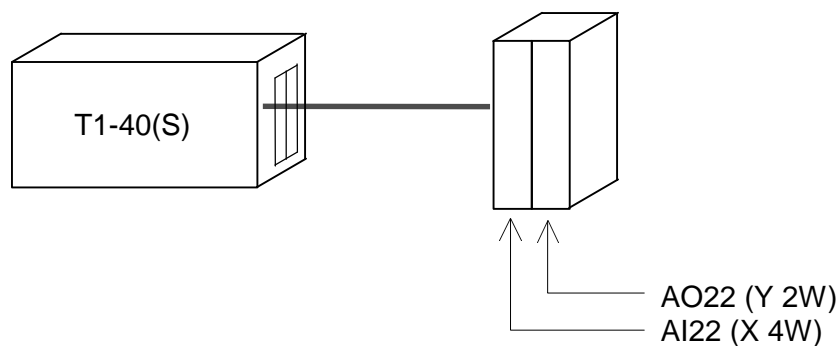

- I/O allocation table and register assignment

Slot PU	I/O type	Assigned register	Assigned device
0	X+Y 4W	XW00, XW01, YW02, YW03	X000 - X00F, X010 - X01F, Y020 - Y02F, Y030 - Y03F
1			
2			
3			
4	X 4W	XW04 - XW07	X040 - X07F
5	Y 2W	YW08, YW09	Y080 - Y09F
6			
7			

- Hardware and register/device relation

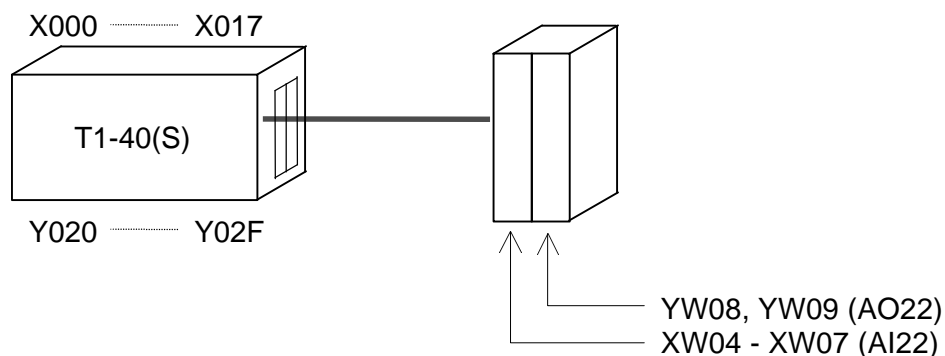

4. I/O Allocation

Example 6 (I/O module)

- Hardware configuration

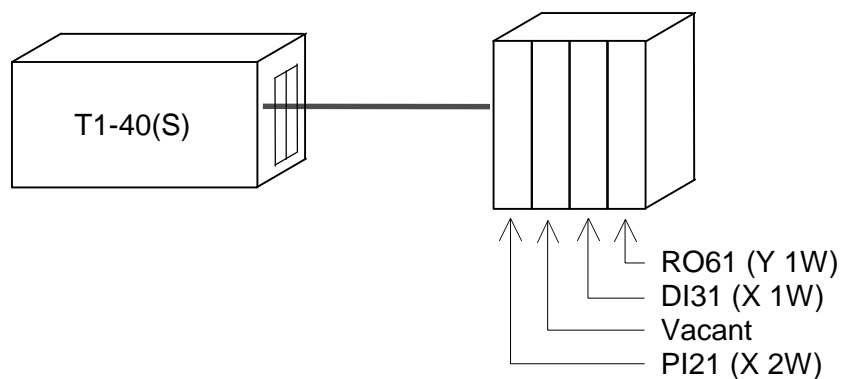

- I/O allocation table and register assignment (using manual I/O allocation)

Slot	I/O type	Assigned register	Assigned device
PU			
0	X+Y 4W	XW00, XW01, YW02, YW03	X000 - X00F, X010 - X01F, Y020 - Y02F, Y030 - Y03F
1	SP 2W	(YW04, YW05)	(Y040 - Y04F, Y050 - Y05F)
2			
3			
4	X 2W	XW06, XW07	X060 - X07F
5			
6	X 1W	XW08	X080 - X08F
7	Y 1W	YW09	Y090 - Y09F

- Hardware and register/device relation

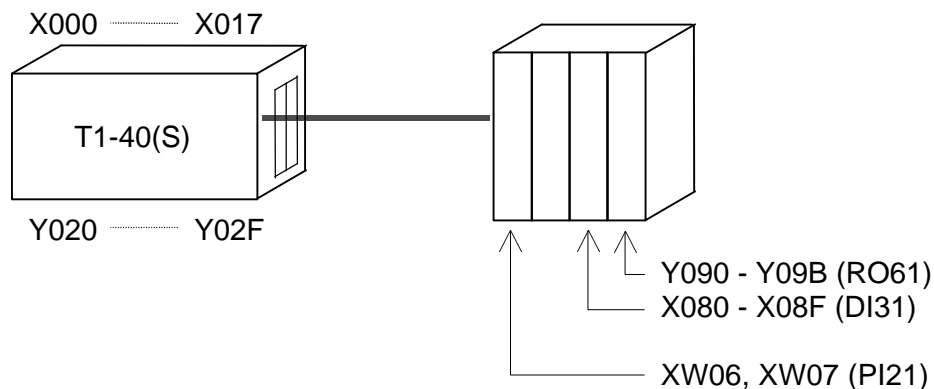

4. I/O Allocation

Example 7 (Option card and I/O module)

- Hardware configuration

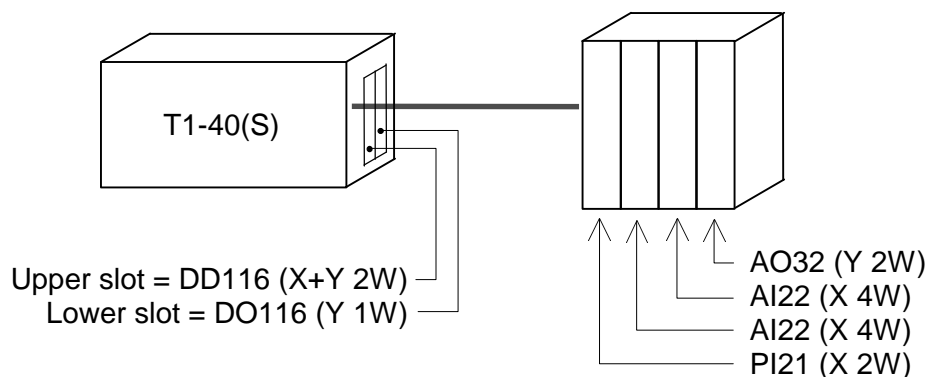

- I/O allocation table and register assignment

Slot	I/O type	Assigned register	Assigned device
PU			
0	X+Y 4W	XW00, XW01, YW02, YW03	X000 - X00F, X010 - X01F, Y020 - Y02F, Y030 - Y03F
1	X+Y 2W	XW04, YW05	X040 - Y04F, Y050 - Y05F
2	Y 1W	YW06	Y060 - Y06F
3			
4	X 2W	XW07, XW08	X070 - X08F
5	X 4W	XW09 - XW12	X090 - X12F
6	X 4W	XW13 - XW16	X130 - X16F
7	Y 2W	YW17, YW18	Y170 - Y18F

- Hardware and register/device relation

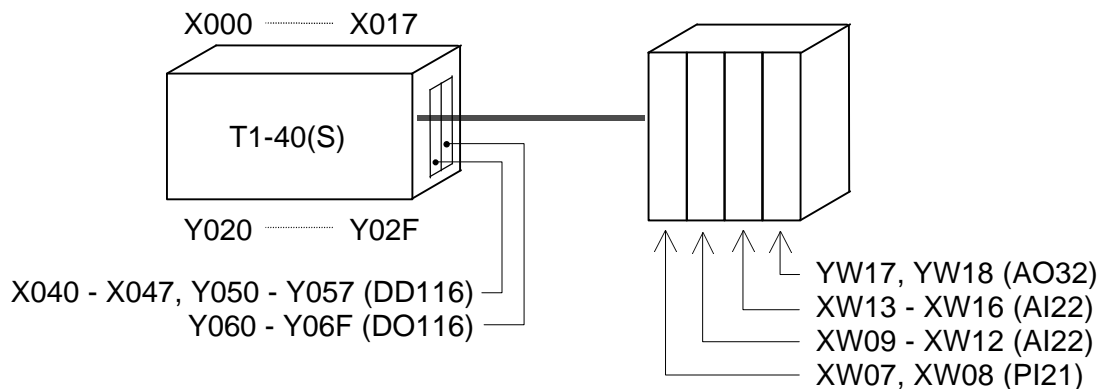

Section 5

Supplement for TOSLINE-F10

- 5.1 Network configuration, 80*
- 5.2 Register assignment, 81*
- 5.3 RAS information, 82*

5. Supplement for TOSLINE-F10

5.1 Network configuration

The FR112 is the TOSLINE-F10 remote station card for the T1-40(S). By using the FR112, high speed data linkage between the T1-40(S) and the upper T-series PLC (T2/T2E/T2N or T3/T3H) becomes available. For details of the TOSLINE-F10 system, read separate TOSLINE-F10 user's manual.

The FR112 works as a remote station. One master station is necessary on a TOSLINE-F10 (hereafter called F10) network.

The F10 master station has 32 words of scan transmission memory. The FR112 shares 2 words of them. (1 word transmit and 1 word receive)

Therefore maximum 16 T1-40(S)'s can be connected to the master station.

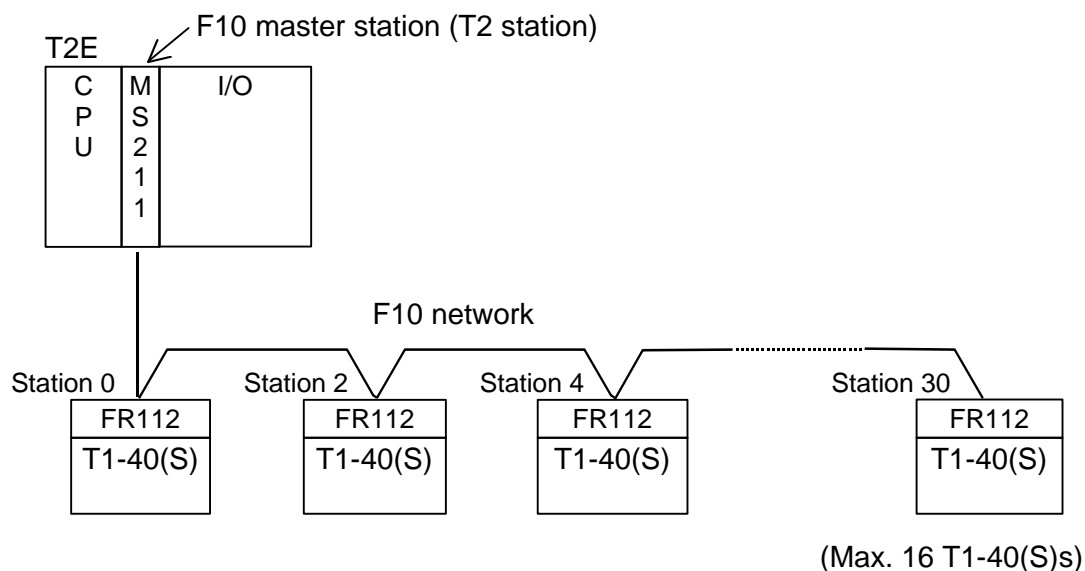

The FR112 shares 2 words of transmission memory. The shared addresses are determined by the station address of the FR112.

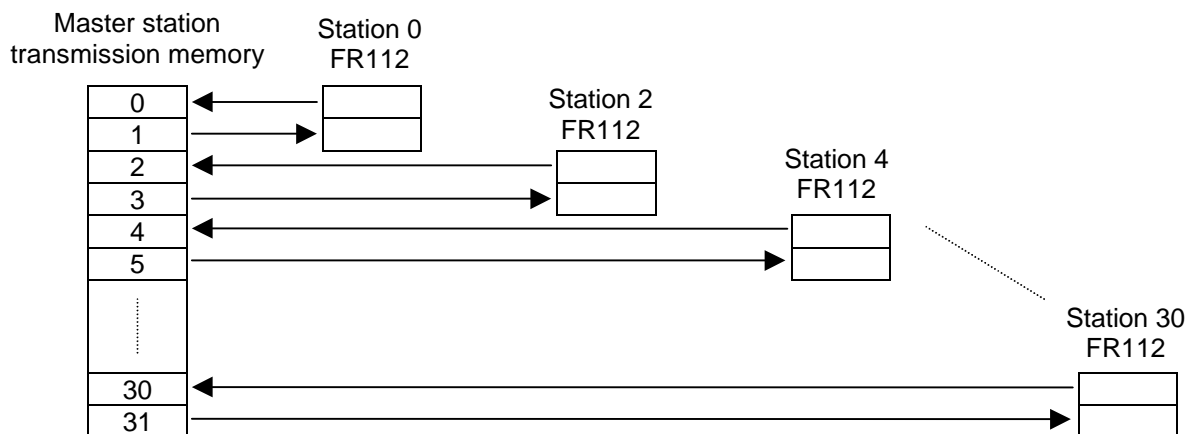

5. Supplement for TOSLINE-F10

5.2 Register assignment

In case of the T2 and T3 stations, the link registers LW are assigned to the TOSLINE-F10 transmission memory.

On the other hand, in case of the T1-40(S), the special registers SW34 and SW35 are assigned fixedly.

SW34 ... Transmit data to the master

SW35 ... Receive data from the master

The figure below shows an example of the data link map.

< System configuration >

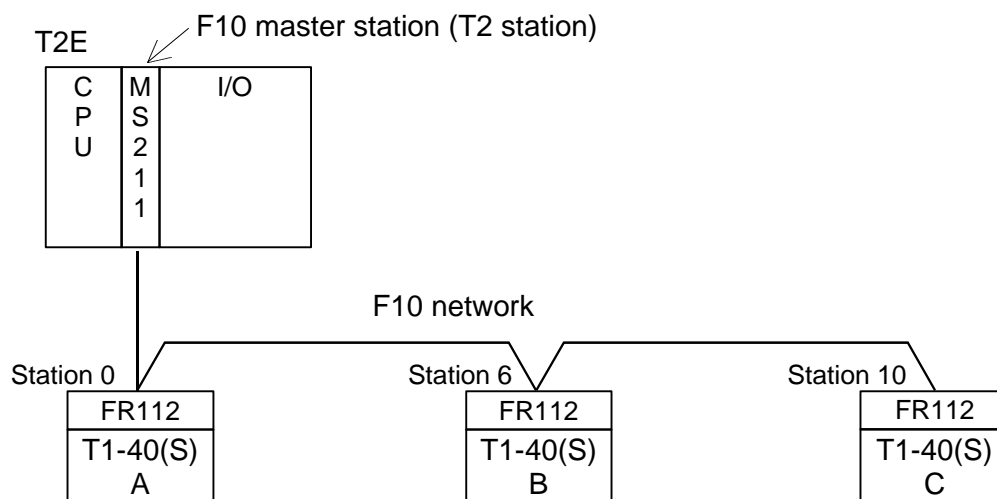

< Data link map >

F10 transmission address	PLC reference				Data source and destination
	T2E Master	T1-40(S) A (#0)	T1-40(S) B (#6)	T1-40(S) C (#10)	
0	LW000	SW34			T2E ← T1-40(S) A
1	LW001	SW35			T2E → T1-40(S) A
⋮	⋮				
6	LW006		SW34		T2E ← T1-40(S) B
7	LW007		SW35		T2E → T1-40(S) B
⋮	⋮				
10	LW010			SW34	T2E ← T1-40(S) C
11	LW011			SW35	T2E → T1-40(S) C
⋮	⋮				

5. Supplement for TOSLINE-F10

5.3 RAS information

On the F10 network, its data linkage system is controlled by the master station. If the master station is failed, entire data linkage is stopped.

In a normal data linkage situation, the transmission data validity is checked by receiver station using CRC.

The table below shows the behavior of the T1-40(S) side in case of F10 related trouble.

Trouble situation	F10 operation	T1-40(S) behavior
Master station down PLC CPU of master station down	Entire data linkage is stopped.	Special device S00D comes ON. Data in SW35 is not changed. T1-40(S) continues running.
Transmission cable broken		
Interference by noise, etc.	Transmission error occurs frequently.	When an error is detected by the FR112, special device S00D comes ON. S00D returns to OFF when data link is recovered. Data in SW35 is not changed during S00D is ON. T1-40(S) continues running.
FR112 hardware error	Momentary transmission error occurs.	
	Data link between the FR112 and master station is stopped.	If the FR112 does not respond to the T1-40(S), the T1-40(S) enters into Error mode. In the Error mode, all outputs of the T1-40(S) are switched OFF, and program execution is stopped. (PLC CPU of master station can know the error)



NOTE The FR112 does not support the F10's read-back check mode.
Do not use the read-back check mode when T1/T1S-40 is linked.

TOSHIBA

TOSHIBA INTERNATIONAL (EUROPE) LTD.

1 Roundwood Avenue
Stockley Park, Uxbridge
Middlesex, ENGLAND UB11 1AR
Tel: 0181-756-6000 Fax: 0181-848-4969

TOSHIBA INTERNATIONAL CORPORATION

Industrial Division
13131 West Little York Road
Houston, TX. 77041, U.S.A.
Tel: 713-466-0277 Fax: 713-466-8773

TOSHIBA INTERNATIONAL CORPORATION PTY. LTD.

Industrial Division
2 Morton Street, Parramatta
N.S.W. 2150, AUSTRALIA
Tel: 02-9768-6600 Fax: 02-9890-7542

TOSHIBA CORPORATION Industrial Equipment Department

1-1, Shibaura 1-chome, Minato-ku
Tokyo 105-8001, JAPAN
Tel: 03-3457-4900 Fax: 03-5444-9268