

## Screw Terminal Ultra-Slim Signal Conditioners M6N Series

### UNIVERSAL TRANSMITTER

(PC programmable)

#### Functions & Features

- Universal input (mV, V, mA, T/C, RTD and potentiometer)
- 7.5-mm ultra-slim transmitter
- 3-port isolation (input to output to power supply)
- Low profile allows the M6N module mounted in a 120-mm deep panel.
- PC programmable
- High-density mounting
- Power indicator LED

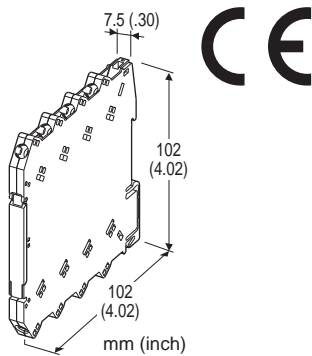

### MODEL: M6NXU-[1][2]-[3]

#### ORDERING INFORMATION

- Code number: M6NXU-[1][2]-[3]  
Specify a code from below for each [1] through [3].  
(e.g. M6NXU-Z1Z1-M2)
- Non-specified orders will be shipped as default factory settings (M6NXU-00: 4 - 20 mA input/4 - 20 mA output).
- Input range (e.g. 4 - 20 mA DC)
- Output range (e.g. 4 - 20 mA DC)

#### [1] INPUT

**0:** User-calibrated (Factory default: 4 - 20 mA DC)  
If the unit is to be factory-calibrated to a specific input type, please select from the following:

##### Current

**Z1:** Range 0 - 50 mA DC (Input resistance 17 Ω)

##### Voltage

**S1:** Range -1000 - +1000 mV DC (Input resistance 1 MΩ min.)

**S2:** Range -10 - +10 V DC (Input resistance 1 MΩ min.)

##### Thermocouple

**T1:** (PR) (Usable Range 0 to 1760°C, 32 to 3200°F)

**T2:** K (CA) (Usable range -270 to +1370°C, -454 to +2498°F)

**T3:** E (CRC) (Usable range -270 to +1000°C, -454 to +1832°F)

- T4:** J (IC) (Usable range -210 to +1200°C, -346 to +2192°F)
- T5:** T (CC) (Usable range -270 to +400°C, -454 to +752°F)
- T6:** B (RH) (Usable range 100 to 1820°C, 212 to 3308°F)
- T7:** R (Usable range -50 to +1760°C, -58 to +3200°F)
- T8:** S (Usable range -50 to +1760°C, -58 to +3200°F)
- TN:** N (Usable range -270 to +1300°C, -454 to +2372°F)
- T0:** Specify (Please provide an emf table.)

#### RTD

**(2- or 3- or 4-wire)**

**R1:** JPt 100 (JIS'89)

(Usable range: -200 to +500°C, -328 to +932°F)

**R3:** Pt 100 (JIS'89)

(Usable range: -200 to +650°C, -328 to +1202°F)

**R4:** Pt 100 (JIS'97, IEC)

(Usable range: -200 to +850°C, -328 to +1562°F)

**R5:** Pt 50 Ω (JIS'81)

(Usable range: -200 to +649 °C, -328 to +1200°F)

**R7:** Pt 1000

(Usable range: -200 to +850°C, -328 to +1562°F)

**R9:** Cu 10 @25°C

(Usable range: -50 to +250°C, -58 to +482°F)

**R0:** Specify (Please provide a resistance table.)

#### Potentiometer

**M1:** Total resistance 100 - 5000 Ω

(Configurator software is used to change input over the described range of the selected suffix code.

For changing between suffix codes, set the Input Range Selector on the side of unit before software adjustment.)

#### [2] OUTPUT

**0:** User-calibrated (Factory default: 4 - 20 mA DC)

If the unit is to be factory-calibrated to a specific output type, please select from the following:

##### Current

**Z1:** Range 0 - 20 mA DC

##### Voltage

**V2:** Range -10 - +10 V DC

**V3:** Range -5 - +5 V DC

(Configurator software is used to change output over the described range of the selected suffix code.

For changing between suffix codes, set the Output Range Selector on the side of unit before software adjustment.)

#### [3] POWER INPUT

##### AC Power

**M2:** 100 - 240 V AC (Operational voltage range 90 - 264 V, 47 - 66 Hz)

##### DC Power

**R:** 24 V DC

(Operational voltage range 24 V ±10 %, ripple 10 %p-p max.)

## RELATED PRODUCTS

- PC configurator software (model: M6CFG)  
Downloadable at M-System's web site.  
A dedicated cable is required to connect the module to the PC. Please refer to the internet software download site or the users manual for the PC configurator for applicable cable types.

## GENERAL SPECIFICATIONS

### Connection

- Input and output:** M3 screw terminal (torque 0.5 N·m)
- Power input:** Via the Installation Base (model: M6NBS) (not available for AC power input)  
or M3 screw terminal (torque 0.5 N·m)
- Recommended solderless terminal:** Max. 5.8 mm (0.23") wide; Ones with insulation sleeve do not fit.  
Applicable wire size 0.2 – 2.5 mm<sup>2</sup>
- Housing material:** Flame-resistant resin (black)
- Isolation:** Input to output to power
- Overrange output:** -2 – +102 %  
(Negative current output is not available.)
- Zero adjustment:** -2 to +2% (PC programming)
- Span adjustment:** 98 to 102% (PC programming)
- Burnout (thermocouple, RTD & potentiometer input):**  
Upscale standard; downscale or no burnout optional by programming
- Linearization (thermocouple & RTD input):** Standard
- Cold Junction Compensation (thermocouple input):** CJC sensor incorporated
- Power LED:** Green light turns on when the power is supplied.
- Status indicator LED:** Orange LED; Flashing patterns indicate different operating status of the transmitter.
- Programming:** Downloaded from PC; input type and range, output type and range, zero and span, burnout type, linearization table, (max. 101 points, specified within -2 – +102% for both input and output), user's TC/RTD table (max. 300 points, specified within -1000 to +1000 mV for TC or 0 to 20 kΩ for RTD), etc.  
For detailed information, refer to the users manual for the PC configurator.
- Configurator connection:** 2.5 dia. miniature jack;  
RS-232C level

### ■ Recommended solderless terminal

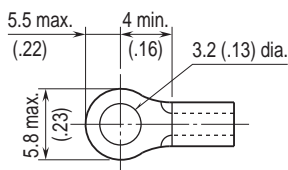

## INPUT SPECIFICATIONS

- **DC Current:** Input resistor incorporated  
(If not specified, the input range is 4 – 20 mA DC.)  
**Input range:** 0 – 50 mA DC  
**Minimum span:** 2 mA  
**Offset:** Lower range can be any specific value within the input range provided that the minimum span is maintained.
- **DC Voltage**  
**Code S1 (narrow spans)**  
**Input range:** -1000 – +1000 mV DC  
**Minimum span:** 100 mV  
**Code S2 (wide spans)**  
**Input range:** -10 – +10 V DC  
**Minimum span:** 1 V  
**Offset:** Lower range can be any specific value within the input range provided that the minimum span is maintained.  
If not specified, the input range is shown below.  
S1: 0 – 100 mV DC  
S2: 1 – 5 V DC
- **THERMOCOUPLE**  
**Input resistance:**  $\geq 1 \text{ M}\Omega$   
**Burnout sensing:**  $\leq 3 \mu\text{A}$   
**Minimum span:** 20°C or 36°F  
If not specified, the input range is shown below.  
T1 PR: 0–1600°C  
T2 K: 0–1000°C  
T3 E: 0–500°C  
T4 J: 0–500°C  
T5 T: 0–300°C  
T6 B: 500–1600°C  
T7 R: 500–1600°C  
T8 S: 0–1600°C  
TN N: 0–1000°C
- **RTD:** 2- or 3- or 4-wire RTD  
**Maximum leadwire resistance:** 10 Ω per wire  
**Sensing current:**  $\leq 1.0 \text{ mA}$   
**Minimum span:** 20°C or 36°F  
If not specified, the input range is 100°C.
- **POTENTIOMETER**  
**Sensing current:**  $\leq 1.0 \text{ mA}$   
**Minimum span**  
0 – 100 Ω : 10 Ω  
0 – 300 Ω : 30 Ω  
0 – 600 Ω : 60 Ω  
0 – 1200 Ω : 120 Ω  
0 – 2500 Ω : 250 Ω  
0 – 5000 Ω : 500 Ω  
If not specified, the input range is 0 – 1200 Ω.

## OUTPUT SPECIFICATIONS

- **DC CURRENT**  
**Output range:** 0 – 20 mA DC

**Conformance range:** 0 – 20.4 mA DC

**Minimum span:** 1 mA

**Offset:** Lower range can be any specific value within the output range provided that the minimum span is maintained.

**Load resistance:** Output drive 11 V max.

(e.g. 4 – 20 mA: 550 Ω [11 V/20 mA])

If not specified, the output range is 4 – 20 mA DC.

• **DC VOLTAGE**

**Code V2 (wide spans)**

**Output range:** -10 – +10 V DC

**Conformance range:** -10.4 – +10.4 V DC

**Minimum span:** 1 V

**Code V3 (narrow spans)**

**Output range:** -5 – +5 V DC

**Conformance range:** -5.2 – +5.2 V DC

**Minimum span:** 0.5 V

**Offset:** Lower range can be any specific value within the output range provided that the minimum span is maintained.

**Load resistance:** Output drive 1 mA max.

(e.g. 1 – 5 V: 5000 Ω [5 V/1 mA])

If not specified, the output range is shown below.

V2: 0 – 10 V DC

V3: 1 – 5 V DC

## INSTALLATION

**Power Consumption**

• **AC Power input:** Max. 2 VA

• **DC Power input:** Approx. 0.5 W

**Operating temperature:** -20 to +55°C (-4 to +131°F)

**Operating humidity:** 30 to 90 %RH (non-condensing)

**Mounting:** Installation Base (model: M6NBS) or DIN rail

**Weight:** 65 g (2.3 oz)

## PERFORMANCE in percentage of span

**Cold junction compensation error (thermocouple input):**

±3°C at 25 ±10°C

±5.4°F at 77 ±18°F

**Temp. coefficient:** ±0.01 %/°C (±0.006 %/°F) of max. span

**Response time:** (0 – 90 %)

DC voltage or current: ≤ 0.5 s

Thermocouple, RTD, potentiometer: ≤ 1 s

**Burnout response time (thermocouple, RTD, potentiometer input):** ≤ 10 s

**Line voltage effect:** ±0.1 % over voltage range

**Insulation resistance:** ≥ 100 MΩ with 500 V DC

**Dielectric strength:** 2000 V AC @1 minute (input to output to power to ground)

## Accuracy

• **DC voltage or current**

**Accuracy:** Input accuracy + output accuracy

Inversely proportional to the span.

**Input accuracy:** (% of range)

-1000 – +1000 mV : ±0.01 %

-10 – +10 V : ±0.01 %

0 – 50 mA : ±0.02 % (Except the accuracy of input resistor.)

**Output accuracy:** ±0.04% of max. output range

**[Example]** Input Type -10 – +10 V, Input Range 1 – 5 V,

Output Type -5 – +5 V, Output Range 1 – 5 V

Input accuracy = Max. Input Range (20 V) / Span (4 V) ×

0.01 % = 0.05 %

Output accuracy = Max. Output Range (10 V) / Span (4 V) ×

0.04 % = 0.1 %

Accuracy = ±0.15 %

• **Thermocouple**

**Overall accuracy:** Input accuracy + output accuracy

**Input accuracy:** Accuracy + Cold Junction Compensation Error 3°C (5.4°F)

**Output accuracy:** Max. Output Range / Span × ±0.04%

T/C	ACCURACY (°C)	CONFORMANCE RANGE (°C)
(PR)	±1.00	0 – 1760
K (CA)	±0.25	-150 – +1370
E (CRC)	±0.20	-170 – +1000
J (IC)	±0.25	-180 – +1200
T (CC)	±0.25	-170 – +400
B (RH)	±0.75	400 – 1760
R	±0.50	200 – 1760
S	±0.50	0 – 1760
N	±0.30	-130 – +1300

T/C	ACCURACY (°F)	CONFORMANCE RANGE (°F)
(PR)	±1.80	32 – 3200
K (CA)	±0.45	-238 – +2498
E (CRC)	±0.36	-274 – +1832
J (IC)	±0.45	-292 – +2192
T (CC)	±0.45	-274 – +752
B (RH)	±1.35	752 – 3200
R	±0.90	392 – 3200
S	±0.90	32 – 3200
N	±0.54	-202 – +2372

**[Example]** K thermocouple, 0 – 1000°C, 4 – 20 mA DC output

Absolute accuracy in °C: 0.25°C (see the above table)  
CJC error (3°C) added: 3.25°C

⇒ Input accuracy = 3.25°C / 1000°C × 100 = 0.325 %

Output span: 16 mA (20 – 4)

⇒ Output accuracy = 20 mA / 16 mA × 0.04 = 0.05 %

➤ Overall accuracy including CJC error =  $0.325 + 0.05 = \pm 0.38$  % of span

## • RTD

**Accuracy:** Input accuracy + output accuracy

Inversely proportional to the span.

**Input accuracy:** (whichever is greater)

$\pm 0.1$  % of input range or  $\pm 0.15^\circ\text{C}$  (Pt and JPt)

$\pm 1^\circ\text{C}$  (Cu 10)

**Output accuracy:**  $\pm 0.04\%$  of max. output range

**[Example]** Pt 100, 0 -  $100^\circ\text{C}$ , Output Type -5 - +5V, Output Range 1 - 5V

Input Accuracy\* ( $0.15^\circ\text{C}^{**}$ ) / Span ( $100^\circ\text{C}$ )  $\times 100$  %

+ Max. Output Range (10V) / Span (4V)  $\times 0.04$  %

=  $\pm 0.25$  %

\* Calculate the accuracy in  $^\circ\text{C}$ .

\*\*  $100^\circ\text{C} \times 0.1$  % =  $0.1^\circ\text{C} \leq 0.15^\circ\text{C}$ .  $0.15^\circ\text{C}$  is used as input accuracy value.

## • Potentiometer

**Accuracy:** Input accuracy + output accuracy

Inversely proportional to the span.

**Input accuracy:** (% of range)

0 -  $100 \Omega$  :  $\pm 0.05$  %

0 -  $300 \Omega$  :  $\pm 0.05$  %

0 -  $600 \Omega$  :  $\pm 0.03$  %

0 -  $1200 \Omega$  :  $\pm 0.03$  %

0 -  $2500 \Omega$  :  $\pm 0.01$  %

0 -  $5000 \Omega$  :  $\pm 0.01$  %

**Output accuracy:**  $\pm 0.04\%$  of max. output range

**[Example]** Total Resistance 0 -  $1200 \Omega$ , Input Range 250-

$750 \Omega$ , Output Type -5 - +5 V, Output Range 1 - 5 V

Max. Input Range ( $1200 \Omega$ ) / Span ( $500 \Omega$ )  $\times 0.03$  %

+ Max. Output Range (10 V) / Span (4 V)  $\times 0.04$  %

=  $\pm 0.18$  %

## STANDARDS & APPROVALS

### CE conformity:

EMC Directive (2004/108/EC)

EN 61000-6-4 (EMI)

EN 61000-6-2 (EMS)

Low Voltage Directive (2006/95/EC)

EN 61010-1

Installation Category II

Pollution Degree 2

Max. operating voltage 300 V

Input or output to power: Reinforced insulation

Input to output: Basic insulation

## EXTERNAL VIEW

■ FRONT VIEW (with the cover open)

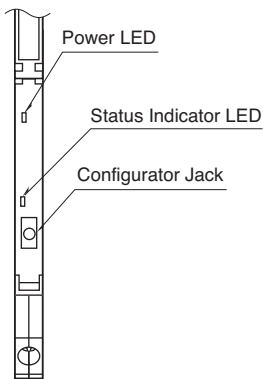

■ SIDE VIEW

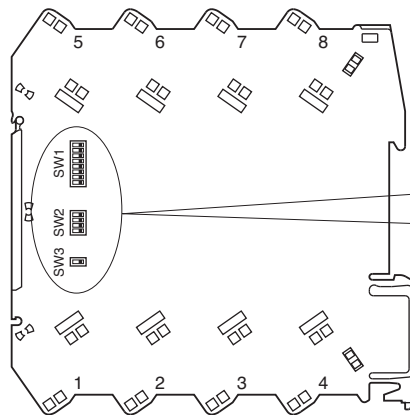

DIP switches for configuration

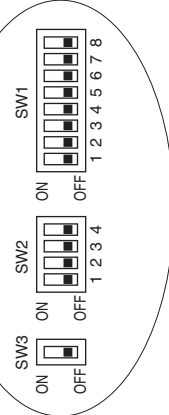

The DIP switch setting is required to select input and output types before setting a precise range using PC Configurator Software (model: M6CFG).  
Refer to the instruction manual for detailed procedures.

## DIMENSIONS unit: mm (inch)

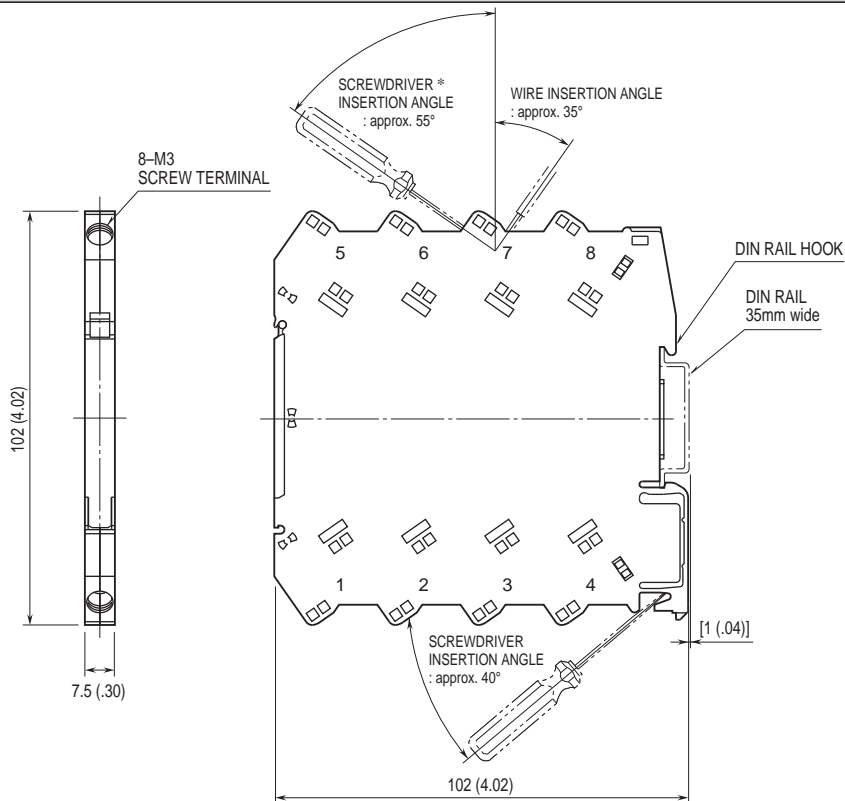

\*Screwdriver stem diameter: 6 mm (.24") or less

• When mounting, no extra space is needed between units.

## SCHEMATIC CIRCUITRY & CONNECTION DIAGRAM

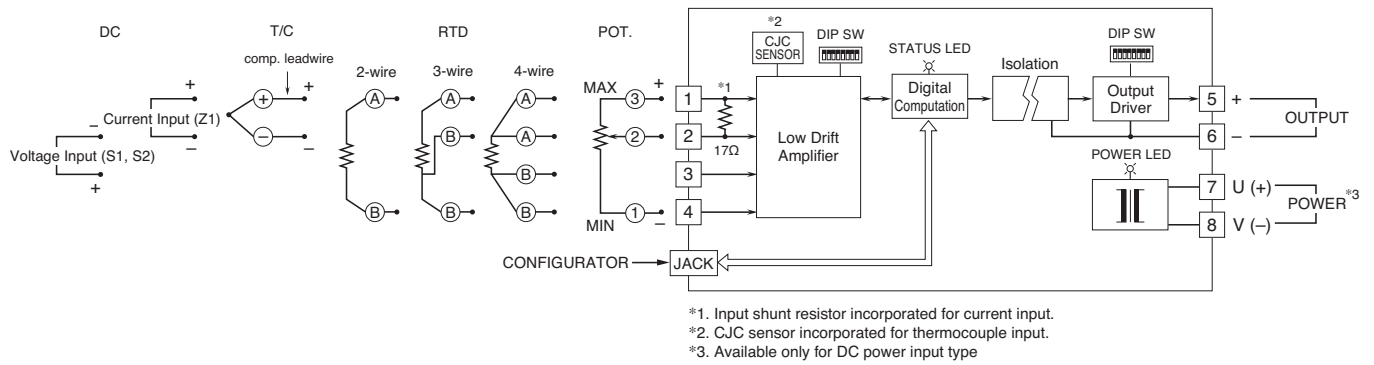

Specifications are subject to change without notice.