



## Bridge Interface



## 851T Transmitters

### Strain Gauge, Load Cell Input

#### Input

##### Sensor types

Load cells (4- or 6-wire configurations), Strain gauges (full-, half-, or quarter-bridge), Millivolt

##### Bridge/gauge resistance

Supports 85 ohms or greater with 10V excitation

##### Input sensitivity

Accepts gauge rated outputs up to 10mV/V DC

##### Internal excitation

Adjustable from 4 to 11V DC, 120mA max.

#### Output

##### Universal output

0 to 20mA (user-configured ranges),  
0 to 10V DC (user-configured ranges),

#### Relay Output (optional)

5A SPDT dry contact relay

#### Power Requirement

12 to 36V DC

#### Approvals

CE marked. UL, cUL listed.

## Strain Gauge / Load Cell Transmitter with Alarm

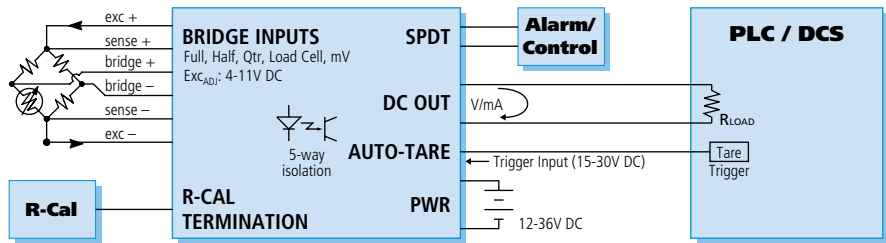

### Description

IntelliPack strain gauge and load cell transmitters offer many powerful features beyond the limited capabilities found in typical bridge amplifiers. 851T models accept signals from sensors wired in a Wheatstone bridge configuration. Common uses include measurement of force, weight, level, torque, acceleration, pressure, and vibration.

The transmitter's input circuit allows true 6-wire bridge measurement and includes an adjustable bridge excitation supply (4 to 11V DC) with a remote sense feature. Sense wires ensure the programmed excitation voltage is applied at the sensor and enable lead-wire compensation. The differential input performs true ratiometric conversions for extremely stable measurements that remain accurate over time and temperature. Plus, lead break detection is inherent in the device.

IntelliPack configuration software simplifies setup for use with basic load cells, millivolt inputs, or seven bridge sensor formats. Internal bridge completion resistors are supplied for half and quarter bridges. The software also downloads sensor parameters such as gauge factor and Poisson's ratio into the transmitter for internal calculation of complex equations to determine sensor strain ( $\epsilon$ ). The strain is then converted to a representative process signal output.

Screw terminals enable a remote "auto-tare" function to compensate for non-zero dead weights and other sensor offsets (e.g. container weight or bridge imbalances). Alternatively, these same screw terminals may be used to reset latched relay alarms.

All these powerful features combined with Acromag's user-friendly configuration software, make the 851T a versatile device that's easy to use and maintain. Plus, a rugged, compact design makes it ideal for use out in the field, on the plant floor, or inside a laboratory.

### Special Features

- Intelligent signal processing functions perform math computations for custom output:
  - strain ( $\epsilon$ ) calculations
  - signal linearization (25 breakpoints)
  - average signal computation
- Relay output option provides local limit alarm capability in addition to the DC output
- Adjustable bridge excitation supports a wide variety of sensor types
- An internal bridge completion function (half-to-full and quarter-to-full) accommodates a broad range of applications
- Remote auto-tare function compensates for extraneous loads and corrects for imbalances in the input bridge
- High-resolution Sigma-Delta A/D converter delivers high accuracy with low noise.
- Windows 95/98/ME/NT/XP/2000 software configuration speeds setup and replacement.

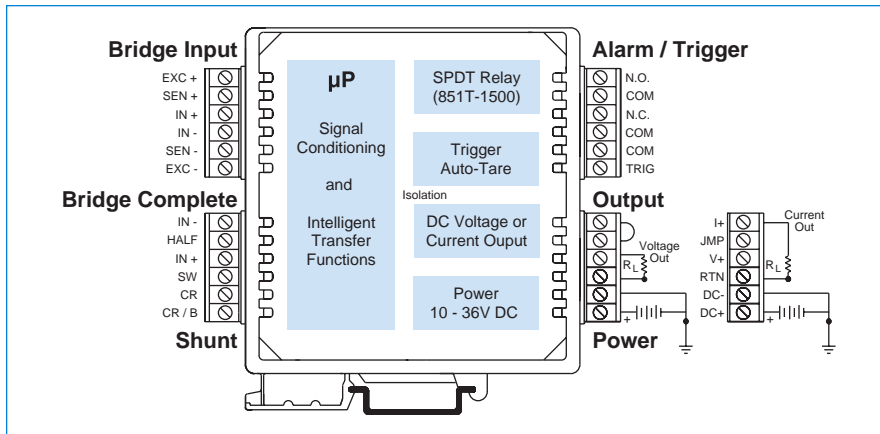

### FULL-BRIDGE INPUT (INTERNAL EXCITATION)

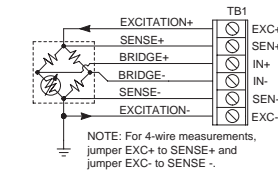

### FULL-BRIDGE INPUT (EXTERNAL EXCITATION)

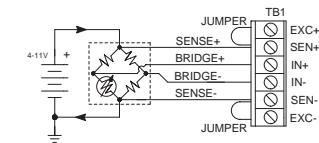

### HALF-BRIDGE INPUT

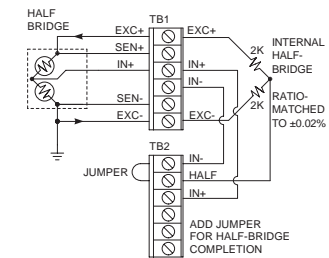

### QUARTER-BRIDGE INPUT

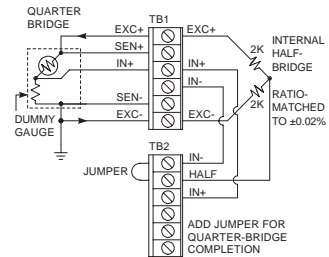

### DIGITAL INPUT "TRIGGER" (AUTO-TARE/RELAY RESET)

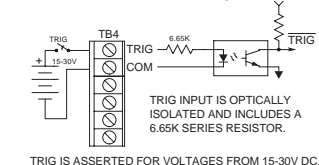

### RELAY OUTPUT

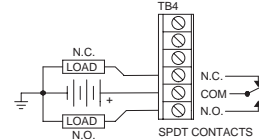

### SHUNT CALIBRATION (R-CAL)

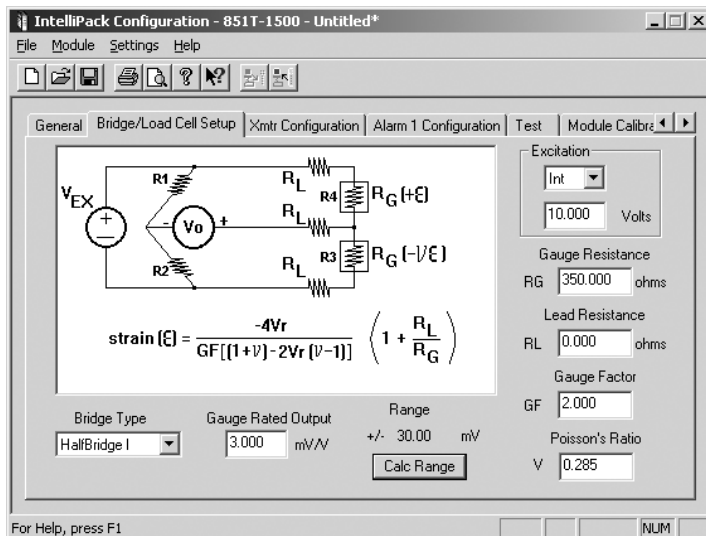
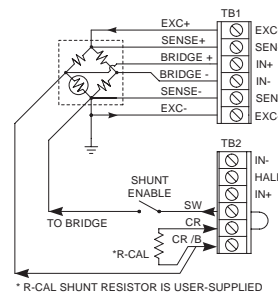

Complex strain ( $\epsilon$ ) calculations are easily configured and computed for full, half, and quarter-bridge sensors.

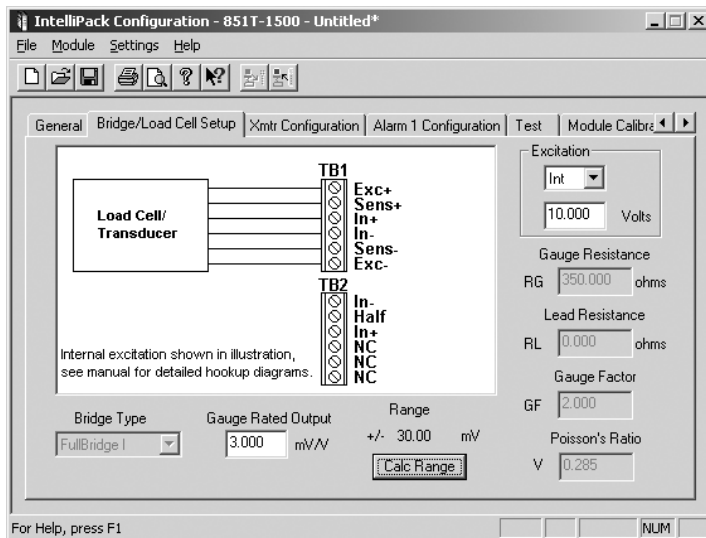

The configuration software makes it easy to set up the transmitter for use with basic load cell sensor devices. Common input sources include pressure transducers, torque converters, and vibration sensors.



## 851T Transmitters

### ■ Performance

#### ■ General Input

Analog to Digital Converter (ADC)  
16-bit  $\Sigma$ - $\Delta$  A/D converter.

**Resolution**  
 $\pm 0.01\%$  of span.

**Input Reference Test Conditions**  
120 ohm full bridge; Excitation = 10V; Rated Output = 3mV/V; Range =  $\pm 30$ mV; Ambient Temperature = 25°C; Power Supply = 24V DC; Alarm Delay = 100ms.

**Accuracy (overall input to output)**  
Better than  $\pm 0.1\%$  of span, typical.  
This value does not include sensor errors.

**Ambient Temperature Effect**  
Better than  $\pm 0.01\%$  of input span per °C ( $\pm 100$ ppm/°C), or  $\pm 1.0$ uV/°C, whichever is greater.

**Response Time (for input step change)**  
250ms to 98% of final output value (into 500 ohms).

**Input Overvoltage Protection**  
Bipolar Transient Voltage Suppressors (TVS).

#### ■ Bridge Input

**Input Types**  
Select from basic load cell, two quarter-bridge options, two half-bridge options, three full-bridge options, or millivolts.

**Input Span/Range**  
Bipolar input range is determined from the  $\pm$  product of the gauge's rated output and the nominal excitation selection (2mV/V x 10V =  $\pm 20$ mV range).

**Input Over-range**  
The actual input range is  $\pm 150\%$  typical of the range obtained via the  $\pm$  product of the gauge's rated output and the nominal excitation applied.

**Input Sensitivity**  
Accepts gauge rated outputs up to 10mV/V. The range of your input signal is the product of the excitation voltage and your gauge's rated output.

**Input Impedance**  
 $\pm 1$ N at 1M ohms min.;  $\pm 5$ EN at 29.09K ohms, typical.

**Input Lead Resistance**  
Module has sufficient overdrive to guarantee 10V bridge excitation with 5 ohms/lead and 100mA of internal excitation current. Larger lead resistances may limit the maximum achievable bridge excitation.

**Input Lead Break Detection**  
Sensor failure detection is upscale only.

**Input Bridge Excitation (Internal)**  
Adjustable from 4V to 11V, 120mA maximum. Internal excitation may be turned OFF for external excitation supply connection.

**Input Bridge Excitation (External)**  
4V to 11V. The internal excitation must be turned OFF for connection to an external excitation supply.

#### ■ Digital (Trigger) Input

**Input Type**  
"Active High" input.  
15-30V DC (6.65K ohms).  
See connection diagram.

**Operation (Tare/Alarm Modes)**  
The trigger function is set for "Auto-Tare" mode by default. This input can also be configured to reset latched alarms via the Configuration Software.

#### ■ Output (DC V/mA)

D/A Converter  
16-bit  $\Sigma$ - $\Delta$ .

**Current Output**  
Ranges: 0-1mA, 0-20mA, 4-20mA.  
Compliance: 10V minimum (500 ohm load).

**Voltage Output**  
Ranges: 0-5V, 0-10V.  
Compliance: 10mA maximum with short circuit protection. 1 ohm output impedance.

#### ■ Output (Relay)

**Relay**  
One SPDT, Form C, dry contact relay.

**Relay Ratings (CSA ratings)**  
25V DC @ 5A, resistive load.  
120/240V AC @ 5A, resistive load.

**Relay Time Delay**  
Adjustable alarm delay of up to 25 seconds.

**Relay Response (No Relay Time Delay)**  
Relay contacts switch within 580ms typical, for an input step change from 10% of span on one side of an alarm point to 5% of span on the other side of the alarm point.

**Initial Dielectric Strength**  
1000V AC rms between open contacts.

**Contact Material**  
Silver-cadmium oxide (AgCdO).

**Expected Mechanical Life**  
20 million operations.

*Performance specifications continued on next page.*



## ■ Environmental

### Ambient Temperature

Operating: -25 to 70°C (-13 to 158°F).  
Storage: -40 to 85°C (-40 to 185°F).

### Relative Humidity

5 to 95%.

### Power Requirements

12 to 36V DC. 11V DC minimum.  
175mA @ 24V. 290mA @ 15V.

### Isolation (optical)

5-way (input/output/relays/trigger/power).  
Input, analog output, trigger, and power circuits are isolated from each other for up to 1500V AC for 60 seconds or 250V AC continuous. Optional relay outputs are isolated from other circuits up to 150V AC, or 150V DC.

### Radiated Field Immunity (RFI)

EN61000-4-3, EN50082-1.

### Electromagnetic Field Immunity (EMI)

Less than ±0.25% of output span effect under the influence of electromagnetic fields from switching solenoids, commutator motors, and drill motors.

### Electrical Fast Transient (EFT)

EN61000-4-4, EN50082-1.

### Surge Withstanding Capability (SWC)

EN61000-4-5, EN50082-1.

### Electrostatic Discharge (ESD)

EN61000-4-2, EN50082-1.

### Radiated Emissions

EN50081-1 for Class B equipment.

### Approvals

CE, UL listed (USA, Canada).  
UL3121 - general product safety.

## ■ Configuration

### Software Configuration

Units are fully programmable via the Windows 95/98/ME/2000/NT/XP IntelliPack Configuration Program. Configuration downloads from PC through EIA232 serial port using Acromag 800C-SIP kit.

### Field Configuration

Output, zero/full-scale, relay setpoint and deadband are configurable via push-buttons and a standard calibrator.

### LED Indicators

LEDs indicate power, status, calibration, and alarm.

## ■ Physical

### Enclosure

Case: Self-extinguishing NYLON type 6.6 polyamide thermoplastic UL94 V-2 NEMA Type 1 enclosure.

### Connectors (Removable Terminal Blocks)

Wire Range: AWG #14-22 (AWG #12 stranded only).

### Printed Circuit Boards

Military grade FR-4 epoxy glass circuit board.

### Dimensions

1.05W x 4.68H x 4.35D inches.  
26.7W x 118.9H x 110.5D millimeters.

### Shipping Weight

1 pound (0.45 Kg) packed.

## ■ Ordering Information

IMPORTANT: All IntelliPacks require initial software configuration (order 800C-SIP). See Note 1 below.

### 851T-0500

IntelliPack transmitter unit, strain gauge input

### 851T-1500

Same as above, plus an SPDT relay output.

### 800C-SIP

Software Interface Package.

Only one kit is required for all IntelliPack models.

See diagram on Page 47 for included parts.

### 5034-225

USB-to-RS232 adapter. See page 91 for more info.

### P55R-D24

Power supply (24V DC, 2.1A).

See Power Supplies on page 183.

### TBK-B02

Optional terminal block kit, barrier strip style, 4 pcs.

### TBK-S02

Optional terminal block kit, spring clamp style, 4 pcs.

NOTE 1: To order factory configuration, call Acromag for a configuration form which must accompany your order. Also, append "-C" to model number (example: 851T-1500-C). 800C-SIP kit is still recommended.



Optional terminal blocks: barrier strip (left) and spring clamp (right). Cage clamp terminal is standard.



## Dimensions

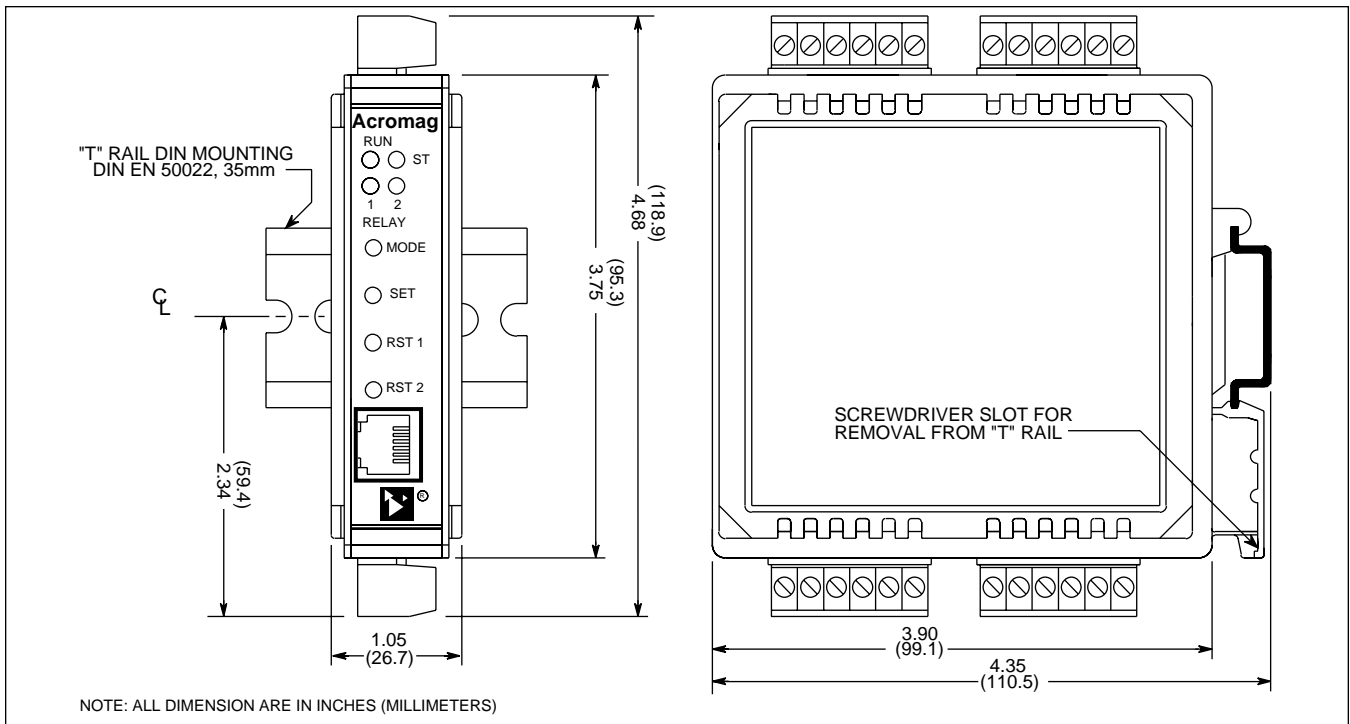



## Accessories

### Terminal Blocks



Barrier strip (left) and spring clamp (right).

#### Ordering Information

See individual I/O modules for compatibility.

#### Barrier Strip Terminal Blocks

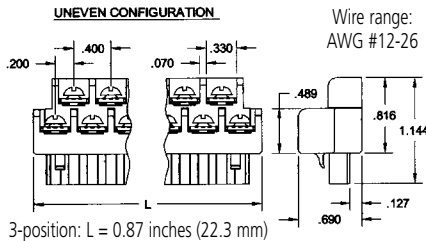
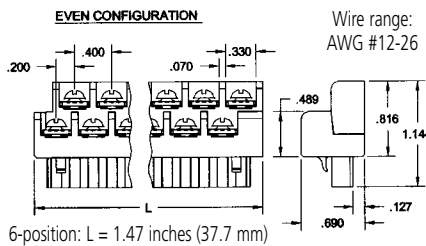

**TBK-B01**  
Terminal block kit,  
two 6-position pieces

**TBK-B02**  
Terminal block kit,  
four 6-position pieces

**TBK-B03**  
Terminal block kit,  
one 3-position and  
three 6-position pieces

#### Spring Clamp Terminal Blocks

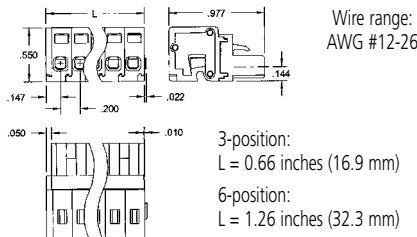

**TBK-S01**  
Terminal block kit,  
two 6-position pieces

**TBK-S02**  
Terminal block kit,  
four 6-position pieces

**TBK-S03**  
Terminal block kit,  
one 3-position and  
three 6-position pieces

### Mounting Hardware



#### DIN-Rail Mounting

For your convenience, Acromag offers several mounting accessories to simplify your system installation. Our 19" rack-mount kit provides a clean solution for mounting your I/O modules and a power supply. Or you can buy precut DIN rail strips for mounting on any flat surface.

#### Ordering Information

20RM-16-DIN  
19" rack-mount kit with DIN rail.

DIN RAIL 3.0  
DIN RAIL 16.7  
DIN rail strip, Type T, 3 inches (75mm) or 16.7 inches (425mm)

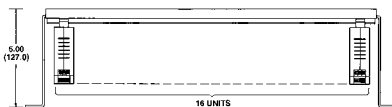
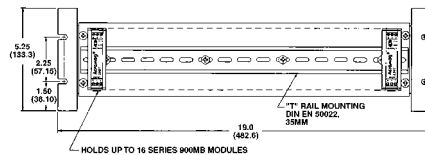

### Power Supplies

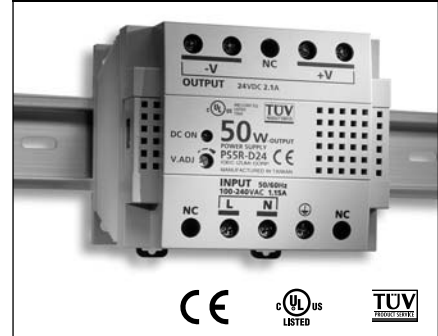

#### 50W Supply

**Input Power Requirement**  
85 to 264V AC or 105 to 370V DC

**Output**  
24V DC, 2.1A (50W)

#### Ordering Information

PS5R-D24  
Universal 50W power supply

See Power Supplies on page 183 for other models and more information.

### USB / RS232 Adapter



Length: 3.15 in (8.0 cm)  
Height: 0.80 in (2.03 cm)  
Width: 1.75 in (4.44 cm)  
Weight: 1.6 oz (45.36 g)

#### Ordering Information

5034-225  
USB-to-RS232 adapter

### AC Current Sensor

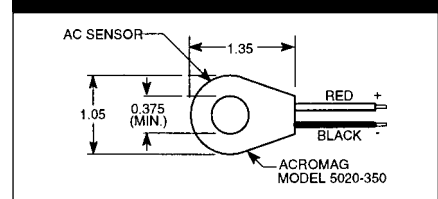

#### Ordering Information

5020-350  
AC current sensor