



Frame grabbers

Matrox Meteor-II/Multi-Channel >>

Low-cost frame grabber for monochrome or component RGB interlaced or progressive scan video acquisition.



Key features

- PCI or PC/104-Plus™ form factor
- captures from interlaced or progressive scan component RGB and single or dual channel monochrome analog video sources
- sampling rates up to 30 MHz
- three 256 x 8-bit LUTs
- connect two RGB or up to six monochrome video sources
- trigger input and timer outputs
- 32-bit / 33 MHz PCI bus-master
- real-time transfer to system or VGA memory
- extensive on-board buffering for reliable capture
- support for packed or planar transfers of color or multiple monochrome streams
- power output¹ and RS-232 serial interface²
- programmed using Matrox Imaging Library (MIL) sold separately
- supports 32-bit Microsoft® Windows® XP

Matrox Meteor-II/Multi-Channel

Matrox Meteor-II/Multi-Channel is part of the Matrox Meteor-II family of high performance frame grabbers for cost sensitive applications. Designed to capture from standard or variable analog monochrome frame scan sources, it specifically supports acquisition from single-channel interlaced or progressive scan monochrome cameras. The three-channel version additionally supports component RGB frame scan and dual-channel progressive scan monochrome cameras. Matrox Meteor-II/Multi-Channel combines extensive functionality with unprecedented value in a frame grabber. OEMs and integrators use this technology to build powerful, yet cost-effective PC-based imaging systems.

VIA: At the heart of the Matrox Meteor-II family

Common to all Matrox Meteor-II boards is the custom-designed Matrox Video Interface ASIC (VIA). It is a sophisticated memory controller for managing real-time acquisition into on-board memory with advanced reformatting capabilities and, in parallel, streaming image data out over the PCI bus without requiring constant host CPU intervention.

Real-time capture to system or display

Matrox Meteor-II/Multi-Channel can transfer acquired images to either system (host CPU) memory for processing or display (VGA) memory for live video-in-a-window at sustained rates up to 130 MB/second.



Matrox Meteor-II/Multi-Channel

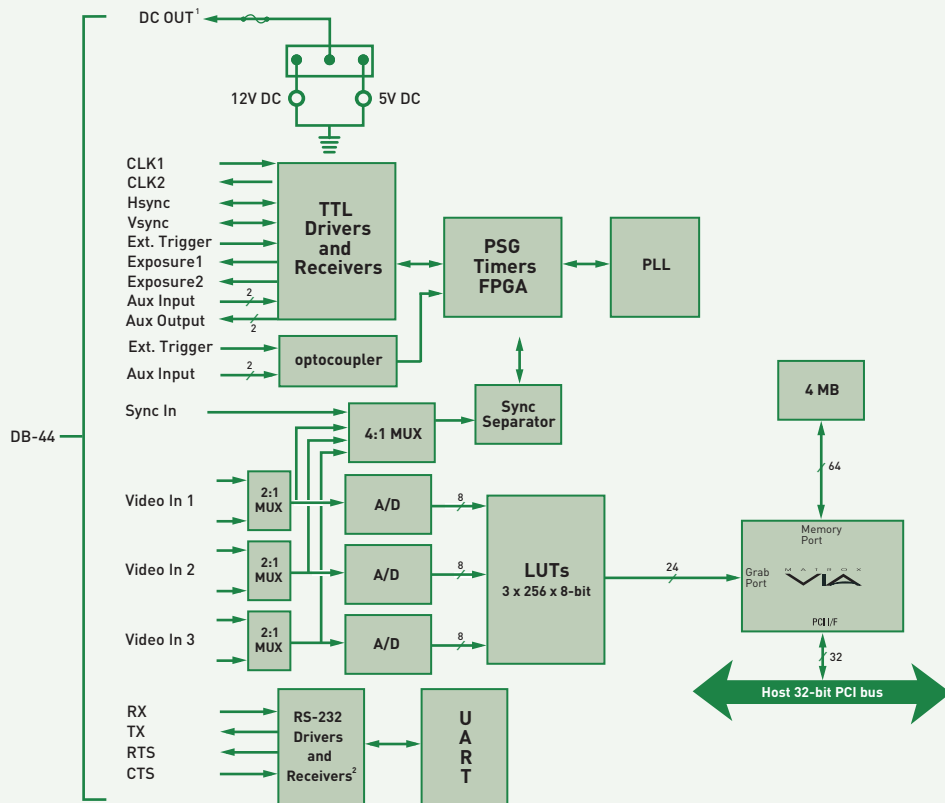

Image formatting

Image data can be reformatted by Matrox VIA in real-time prior to transfer to host system or display. Features of Matrox VIA include cropping (ROI capture), independent horizontal and vertical sub-sampling from 2 to 16 (by decimation).

Matrox VIA can also perform reformatting operations specifically designed for reconstructing images from multi-tap cameras in real-time. Image data presented simultaneously in either odd/even pixel, odd/even line, opposite scan segments or a combination, can be re-ordered into a proper image with little or no host CPU involvement.

Power output¹

Matrox Meteor-II/Multi-Channel can supply 5 or 12V DC power to cameras. Power is taken directly from the PC power supply, preventing any overload to the PCI bus.

RS-232 serial interface²

Matrox Meteor-II/Multi-Channel features an RS-232 serial interface to enable remote programming of a camera (i.e., gain, gamma control, operation mode), motion control unit or PLC.

PCI interface

Matrox Meteor-II/Multi-Channel features a 32-bit PCI bus master/slave host interface. The bus master mode performs transfers without requiring continuous host intervention at rates up to 130 MB/second sustained.

Extensive buffering ensures reliable real-time transfer of incoming image data to host memory even under high bus latency conditions, which typically occurs in systems with concurrent image capture, display, graphics, network access, disk access and general external I/O. The PCI interface supports image data sub-sampling from 2 to 16 (by decimation) to further reduce required PCI bus bandwidth.

The PCI interface also supports packed or planar transfers of color or multiple monochrome streams. Acquisition-related events such as start and end of frame, and field or sequence capture can be routed to the host CPU as interrupts to optimize concurrent acquisition and processing (double-buffering).

Field-proven application development software

Matrox Meteor-II/Multi-Channel is supported by the Matrox Imaging Library (MIL), a comprehensive collection of software tools for developing industrial imaging applications. MIL features interactive software and programming functions for image capture, processing, analysis, annotation, display and archiving. These tools are designed to enhance productivity, thereby reducing the time and effort required to bring your solution to market. Refer to the MIL datasheet for more information.

Specifications

Acquisition

- up to three-channels analog variable frame scan
- monochrome or RGB interlaced or progressive scan
- sampling rate up to 30 MHz
- SNR of 47 dB
- pixel jitter of ± 1.5 ns
- variable gain amplifier
- 10 MHz input low pass filter
- adjustable ADC references
- three 256 x 8-bit programmable LUTs
- separate TTL pclk (in and out), hsync (in or out), vsync (in or out) and two timer (exposure) outputs
- two opto-isolated differential auxiliary inputs³ and two TTL auxiliary inputs and outputs
- opto-isolated differential and TTL trigger inputs (synchronous and asynchronous to video)
- connect and switch between 2 RGB or up to 6 monochrome sources

Formatting

- input cropping (ROI capture)
- independent horizontal and vertical sub-sampling from 2 to 16 (by decimation)

RS-232 interface²

- supports RX, TX, RTS and CTS signals
- not visible to OS (controlled through MIL API)

Power output¹:

- 5 or 12V DC at 3A
- from PC power supply (not PCI slot)

Host interface

- 32-bit PCI bus master/slave
- up to 130 MB/second sustained
- 4 MB buffer
- support for packed or planar image data formats
- independent horizontal and vertical sub-sampling both from 2 to 16 (by decimation)
- interrupts for start and end of field, frame and sequence capture
- universal 32-bit card edge connector

Dimensions and environmental information

- PCI version⁴:
 - 16.5 L x 10.67 H cm (6.5" x 4.2")
- PC/104-Plus™ version⁵:
 - 11.56 L x 9.6 H cm (4.55" x 3.78")
- operating temperature: 0° C to 55° C (32° F to 131° F)
- relative humidity: up to 95% (non-condensing)
- FCC class A
- CE class A
- RoHS-compliant

Software Driver

- Matrox Imaging Library (MIL) driver for 32-bit Microsoft® Windows® XP

Ordering Information

Hardware

Part number	Description
METEOR2-MC/1C*	Standard/non-standard single channel analog monochrome frame grabber.
METEOR2-MC/4* (PCI)	Standard/non-standard 3-channel analog RGB/monochrome frame grabber.
MET2-MC+*(PC/104-Plus™)	

Software

Refer to MIL datasheet.

Input cables

DBHD44-T0-8BNC	2.13 m (7') input cable, high density DB-44 to eight BNCs.
DH44-T0-8BNC/0	1.82 m (6') input cable, high density DB-44 to eight BNCs and open end (to access sync. and control signals).

Notes:

1. Power output not available on PC/104-Plus™ version.
2. RS-232 interface not present on PC/104-Plus™ version.
3. TTL inputs on PC/104-Plus™ version.
4. Vertical dimensions are from bottom edge of goldfinger to top edge of board. Horizontal dimensions are from edges of board excluding bracket.
5. Vertical and horizontal dimensions are from edges of board.
6. Contact local representative or Matrox Imaging Sales for availability.

Corporate headquarters:

Matrox Electronic Systems Ltd.
1055 St. Regis Blvd.
Dorval, Quebec H9P 2T4
Canada
Tel: +1 (514) 685-2630
Fax: +1 (514) 822-6273

For more information, please call: 1-800-804-6243 (toll free in North America) or (514) 822-6020
or e-mail: imaging.info@matrox.com or <http://www.matrox.com/imaging>

matrox®

All trademarks by their respective owners are hereby acknowledged. Matrox Electronic Systems, Ltd. reserves the right to make changes in specifications at any time and without notice. The information furnished by Matrox Electronic Systems, Ltd. is believed to be accurate and reliable. However, no responsibility license is granted under any patents or patent rights of Matrox Electronic Systems, Ltd. Windows and Microsoft are trademarks of Microsoft Corporation. MMX and the MMX logo are registered trademarks of Intel Corporation. Printed in Canada, 2009-02-17. **51E-5151-B**