



CA3

High Performance – Low Power 3U CompactPCI® Single Board Computer

Features

- Intel® Celeron® 650 Ultra Low Voltage processor
- System controller or peripheral card operation
- 256 MB SDRAM
- 64-bit 100 MHz memory bus
- 512 KB boot flash
- UltraDMA33 ATA interface
- Real-Time Clock with battery back-up
- Floppy drive interface
- Two Fast Ethernet ports 10/100 BaseT front-panel RJ-45 connector and rear I/O
- Two serial ports
- IEEE 1284 Parallel port
- Front-panel PS/2 keyboard/mouse port
- Two rear I/O USB ports
- Front-panel reset button
- Front-panel status LEDs
- Watchdog, temperature sensors

CA3 is a CompactPCI Single Board Computer (SBC) with an Intel® Celeron® 650MHz Ultra Low Voltage (ULV) processor in a convection-cooled 3U form factor.

The CA3 is designed for embedded processing applications using PCI-based 32-bit* architecture.

The CA3 includes 256 MB of SDRAM and 512 KB of boot flash. For increased flexibility, CA3 includes two serial ports, two USB ports, a parallel port, a front-panel PS/2 keyboard and mouse port, floppy drive interface, and an UltraDMA33 IDE interface for attaching an IDE hard drive or flash disk through the on-board J4 connector. For network accessibility, the CA3 also includes a dual channel 82546EB

Ethernet chip that routes one channel through a front-panel RJ-45 connector with operation and activity LEDs and a second channel routed to the rear I/O.

The Intel ULV Celeron 650 processor makes the CA3 ideal for power-critical applications. It is based on the same core as the Pentium® processor and is optimized for high performance with low power consumption (+1.1V at 650MHz).

The dual-mode functionality of the PCI 6254 (formerly the HB6) PCI/PCI Bridge, the CA3 offers the versatility of operating as a system controller or peripheral card.

*The CA3 does not support 64-bit backplane.



CA3 High Performance – Low Power 3U CompactPCI® Single Board Computer

Specifications

Processor - ULV Celeron 650

- Ultra Low Voltage 1.10V @ 650 MHz, 0.95 @ 400 MHz
- Same core as Intel® Pentium III processor
- 16KB L1 data and instruction caches
- 256KB shared L2 cache

PCI Bridge - 82443MX100

- 100 MHz, 64-bit system bus
- SDRAM controller with 64-bit 100 MHz memory interface
- Interrupt controller
- 32-bit 33MHz PCI bus interface
- UltraDMA/33 ATA controller
- DMA controller
- Three internal timers
- Real-Time Clock for date and time keeping with battery back-up and 128-byte SRAM
- Two USB serial ports
- General purpose I/O
- XBus interface
- SMBus serial link port

Memory - PC100

- 256 MB SDRAM
- 64-bit 100 MHz memory bus
- Rugged design with soldered chips

PCI/PCI Bridge - 6254 PCI/PCI Bridge

- Dual mode operation for system controller and peripheral card functionality

Flash - 29LV040

- 512 KB
- Hardware selected write protection

Super I/O - FDC37B727

- 8-bit interface
- Two NS16C550A-compatible UART serial ports
- Parallel port
- Front-panel PS/2 keyboard and mouse port
- Floppy drive controller
- Watchdog timer
- General purpose I/O

Ethernet - 82546EB

- IEEE 802.3 Ethernet 100Base-TX, and 10Base-T operation
- Dual channel
- Full-duplex operation
- Two independent MAC and PHY functions with common
- PCI host interface
- Front-panel RJ-45 connector and rear-panel I/O

Temperature Sensor - MAX6658

- On-board temperature monitoring and processor-temperature monitoring

JTAG Scan Chain

- ULV Celeron 650 (tested separately)
- 82549EB Ethernet controller
- PCI 6254 PCI/PCI Bridge
- XC95144XL CPLD

Power Requirements

- +5V, +3.3V Required

Power Consumption - Typical current

- 15W Typical (20W max.)*
- *Power values are preliminary estimates

Temperature

- Highest reachable operating temperature depends on ambient conditions (airflow) as shown below. All values under typical conditions.

	Operating	Storage
Standard	0°C to +70°C	-40°C to +85°C

Humidity

- Operating: 5 - 95% @ 40°C
- Storage: 5 - 95% @ 40°C

Altitude

- Operating: 15,000 ft. (4.5 km)
- Storage: 40,000 ft. (12 km)

Shock

- C-, I-Style 12g / 6 ms

Vibration

- C-, I-Style 2g rms / 5-100 Hz

MTBF

- Calculations TBD in accordance with MIL-HDBK-217, please contact the factory

Safety

- All PWBs are manufactured with flammability rating of 94V-0 by UL recognized manufacturer

Configuration Matrix

C	A	3	X	X	2	2	C
			0				No CompactFlash carrier
			1				Includes CompactFlash carrier site
				0			No CompactFlash
				1			64 MB CompactFlash
				2			128 MB CompactFlash
				3			256 MB CompactFlash
					1		Reserved
					2		256 MB DRAM
						1	Reserved
						2	650 MHz
							C Convection-cooled

Grayed options are not offered



CA3 High Performance – Low Power 3U CompactPCI® Single Board Computer

Ordering Information

Configuration Options

See Configuration Matrix

Accessories

TM-CA3 I/O Transition Modules XB-CA3-CFIDE

Daughter card

Operating Systems

GE Technologies offers a VxWorks BSP

Block Diagram

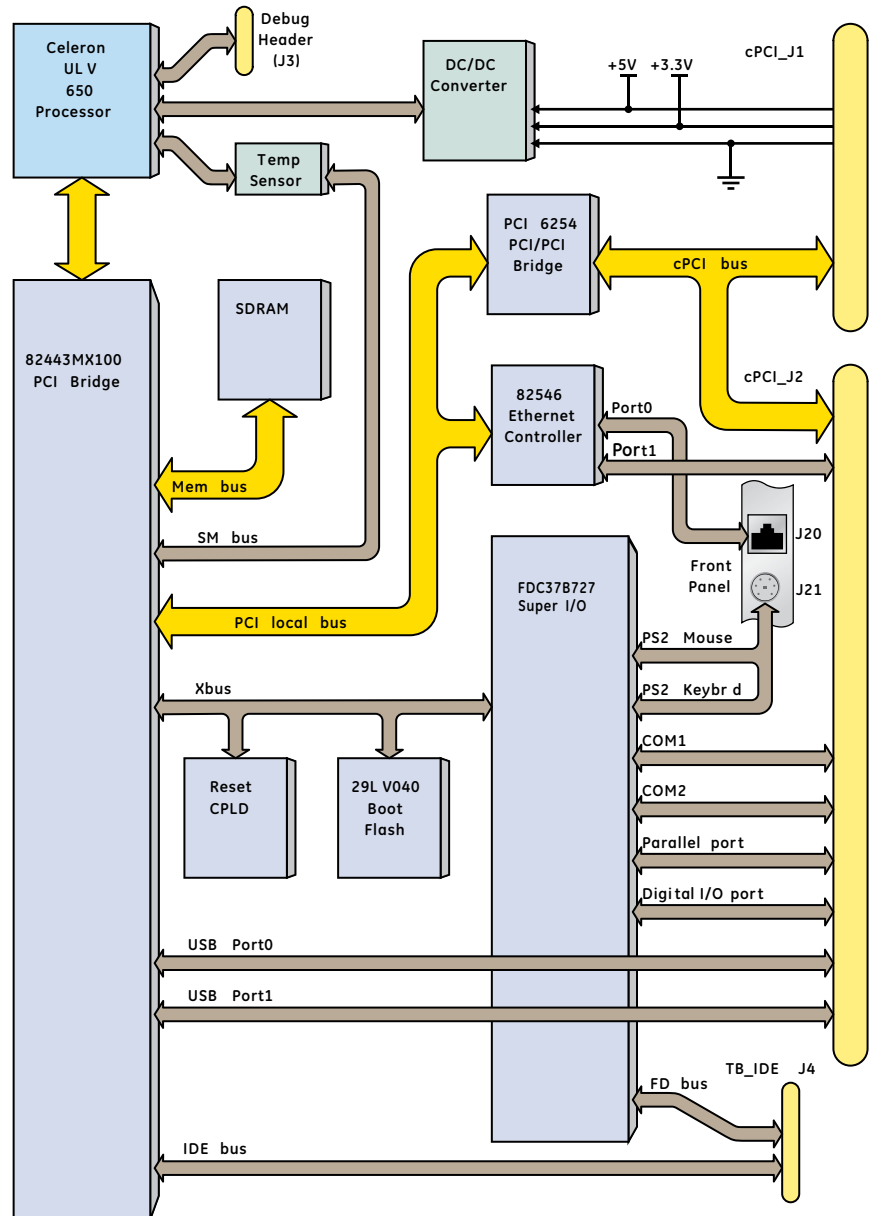

GE Intelligent Platforms Contact Information

Americas: 1 800 433 2682 or 1 434 978 5100

Global regional phone numbers are listed by location on our web site at www.ge-ip.com/contact

www.ge-ip.com

