

SPECIFICATION FOR APPROVAL

- (●) Preliminary Specification
- () Final Specification

Title	17.1" WXGA TFT LCD
--------------	---------------------------

BUYER	
MODEL	-

SUPPLIER	LG.Philips LCD Co., Ltd.
*MODEL	LM171W02
SUFFIX	TTA1

*When you obtain standard approval, please use the above model name without suffix

APPROVED BY	SIGNATURE DATE
/	_____
/	_____
/	_____

Please return 1 copy for your confirmation with your signature and comments.

APPROVED BY	SIGNATURE DATE
S.G.Hong / G.Manager	_____
REVIEWED BY	
P.Y.Kim / Manager	_____
PREPARED BY	
D.Y.Lee / Engineer	_____

MNT Products Engineering Dept.
LG. Philips LCD Co., Ltd

Product Specification

Contents

No	ITEM	Page
	COVER	1
	CONTENTS	2
	RECORD OF REVISIONS	3
1	GENERAL DESCRIPTION	4
2	ABSOLUTE MAXIMUM RATINGS	5
3	ELECTRICAL SPECIFICATIONS	6
3-1	ELECTRICAL CHARACTREISTICS	6
3-2	INTERFACE CONNECTIONS	9
3-3	SIGNAL TIMING SPECIFICATIONS	11
3-4	SIGNAL TIMING WAVEFORMS	12
3-5	COLOR INPUT DATA REFERNECE	13
3-6	POWER SEQUENCE	14
3-7	V _{LCD} POWER DIP CONDITION	15
4	OPTICAL SFECIFICATIONS	16
5	MECHANICAL CHARACTERISTICS	20
6	RELIABILITY	23
7	INTERNATIONAL STANDARDS	24
7-1	SAFETY	24
7-2	EMC	24
8	PACKING	25
8-1	DESIGNATION OF LOT MARK	25
8-2	PACKING FORM	25
9	PRECAUTIONS	26

Product Specification

1. General Description

LM171W02 is a Color Active Matrix Liquid Crystal Display with an integral Cold Cathode Fluorescent Lamp(CCFL) backlight system. The matrix employs a-Si Thin Film Transistor as the active element. It is a transmissive type display operating in the normally white mode. It has a 17.1 inch diagonally measured active display area with WXGA resolution (900 vertical by 1440 horizontal pixel array).

Each pixel is divided into Red, Green and Blue sub-pixels or dots which are arranged in vertical stripes. Gray scale or the brightness of the sub-pixel color is determined with a 6-bit gray scale signal for each dot, thus, presenting a palette of more than 262,144 colors.

It has been designed to apply the 8-bit TMD5 interface.

It is intended to support applications where high brightness, super wide viewing angle, high color saturation, and high color are important.

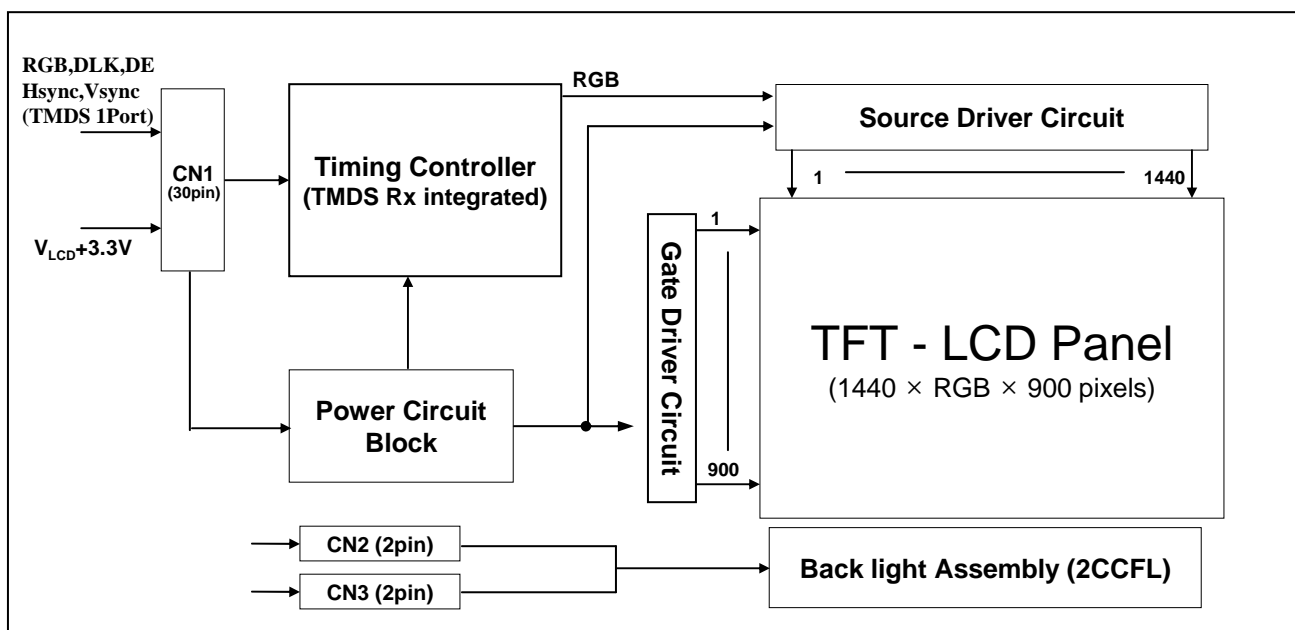

General Features

Active Screen Size	17.1 inches(43.3019cm) diagonal (Aspect ratio 16:10)
Outline Dimension	395(H) x 256.4 (V) x 11(D) mm (Typ.)
Pixel Pitch	0.255mm x 0.255mm
Pixel Format	1440 horiz. By 900 vert. Pixels RGB strip arrangement
Color Depth	262,144 colors (6bit)
Luminance, White	250 cd/m ² (Center 1 points Typ.)
Viewing Angle (CR>10)	R/L 140(Typ.), U/D 120(Typ)
Power Consumption	Total 10.38 Watt(Typ.) (2.14 Watt@V _{LCD} , 10.24 Watt@250cd/[Lamp=8mA])
Weight	1,220 g (Typ.)
Display Operating Mode	Transmissive mode, normally white
Surface Treatment	Hard coating(3H),Anti-glare treatment of the front polarizer

Product Specification

2. Absolute Maximum Ratings

The following are maximum values which, if exceeded, may cause faulty operation or damage to the unit.

Table 1. ABSOLUTE MAXIMUM RATINGS

Parameter	Symbol	Values		Units	Notes
		Min	Max		
Power Input Voltage	VLCD	-0.3	+4.0	Vdc	at 25 ± 2 °C
Operating Temperature	T _{OP}	0	50	°C	1
Storage Temperature	T _{ST}	-20	60	°C	1
Operating Ambient Humidity	H _{OP}	10	90	%RH	1
Storage Humidity	H _{ST}	10	90	%RH	1

Note : 1. Temperature and relative humidity range are shown in the figure below.
Wet bulb temperature should be 39 °C Max, and no condensation of water.

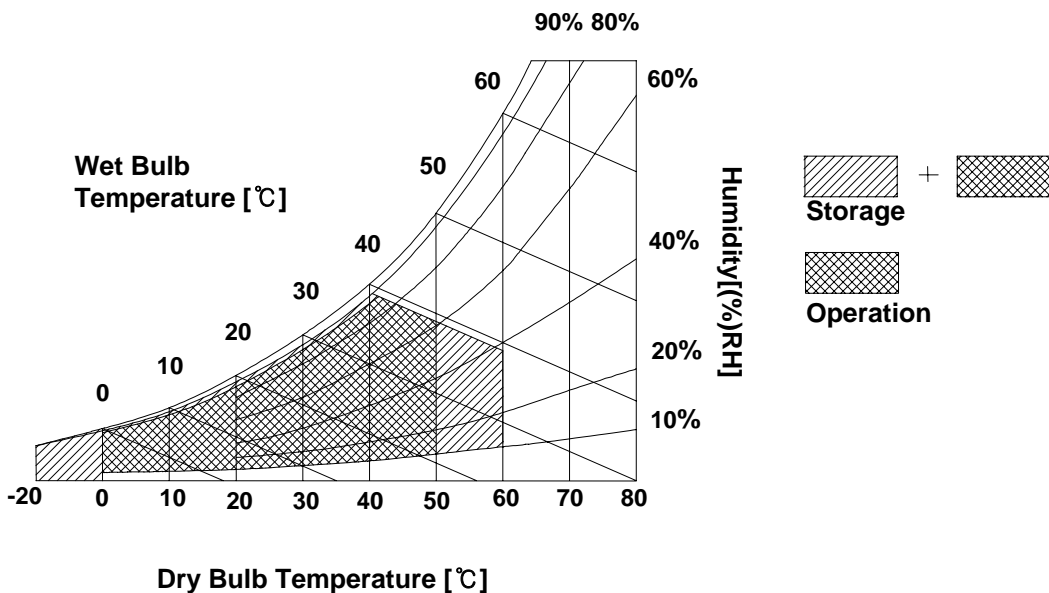

Product Specification

3. Electrical Specifications

3-1. Electrical Characteristics

It requires two power inputs. One is employed to power the LCD electronics and to drive the TFT array and liquid crystal. The second input power for the CCFL, is typically generated by an inverter. The inverter is an external unit to the LCDs.

Table 2_1. ELECTRICAL CHARACTERISTICS

Parameter	Symbol	Values			Unit	Notes
		Min	Typ	Max		
MODULE :						
Power Supply Input Voltage	V _{LCD}	3.15	3.3	3.50	Vdc	
Power Supply Input Current	I _{LCD}	-	648	745	mA	1
		-	824	947	mA	2
Power Consumption	P _{LCD}	-	2.14	2.61	Watt	1

Note :

1. The specified current and power consumption are under the $V_{LCD}=3.3V, 25 \pm 2^{\circ}C, f_V=60Hz$ condition whereas mosaic pattern(8 x 6) is displayed and f_V is the frame frequency.
2. The current is specified at the maximum current pattern.

White : 63Gray
Black : 0Gray

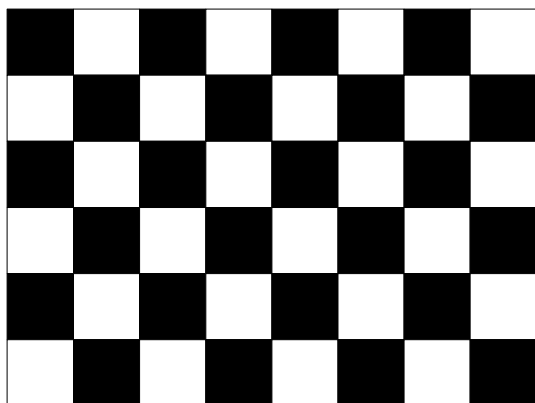

Mosaic Pattern(8 x 6)

Maximum current pattern

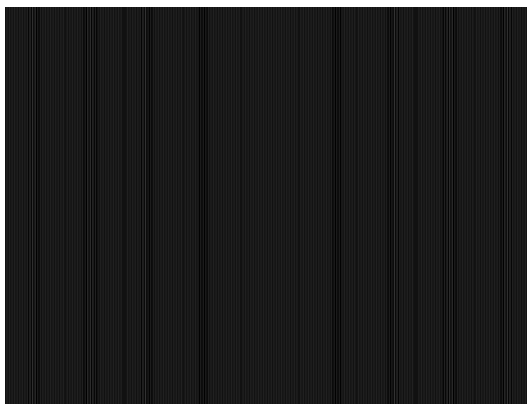

Vertical 2 by 2 (Gray 15)

Product Specification

Table 2_2. ELECTRICAL CHARACTERISTICS

Parameter	Symbol	Values			Unit	Notes
		Min	Typ	Max		
LAMP :						
Operating Voltage	V _{BL}	615(9mA)	640(8mA)	750(2.5mA)	V _{RMS}	1, 2
Operating Current	I _{BL}	2.5	8.0	9.0	mA _{RMS}	1
Established Starting Voltage	V _S					1, 3
	at 25 °C			1000	V _{RMS}	
	at 0 °C			1300	V _{RMS}	
Operating Frequency	f _{BL}	40	60	80	kHz	4
Discharge Stabilization Time	T _S			3	Min	1, 5
Power Consumption	P _{BL}		10.24	11.26	Watt	6
Life Time		40,000			Hrs	1, 7

Note : The design of the inverter must have specifications for the lamp in LCD Assembly.

The performance of the Lamp in LCM, for example life time or brightness, is extremely influenced by the characteristics of the DC-AC inverter. So all the parameters of an inverter should be carefully designed so as not to produce too much leakage current from high-voltage output of the inverter.

When you design or order the inverter, please make sure unwanted lighting caused by the mismatch of the lamp and the inverter (no lighting, flicker, etc) never occurs. When you confirm it, the LCD-Assembly should be operated in the same condition as installed in you instrument.

※ Do not attach a conducting tape to lamp connecting wire.

If the lamp wire attach to a conducting tape, TFT-LCD Module has a low luminance and the inverter has abnormal action. Because leakage current is occurred between lamp wire and conducting tape.

1. Specified values are for a single lamp.

2. Operating voltage is measured at $25 \pm 2^\circ\text{C}$. The variance of the voltage is $\pm 10\%$.

3. The voltage above V_S should be applied to the lamps for more than 1 second for start-up.

(Inverter open voltage must be more than lamp starting voltage.)

Otherwise, the lamps may not be turned on. The used lamp current is the lamp typical current.

4. Lamp frequency may produce interface with horizontal synchronous frequency and as a result this may cause beat on the display. Therefore lamp frequency shall be as away possible from the horizontal synchronous frequency and from its harmonics in order to prevent interference.

5. Let's define the brightness of the lamp after being lighted for 5 minutes as 100%.

T_S is the time required for the brightness of the center of the lamp to be not less than 95%.

6. The lamp power consumption shown above does not include loss of external inverter.

The used lamp current is the lamp typical current. ($P_{BL} = V_{BL} \times I_{BL} \times$)

7. The life is determined as the time at which brightness of the lamp is 50% compared to that of initial value at the typical lamp current on condition of continuous operating at $25 \pm 2^\circ\text{C}$.

Product Specification

8. The output of the inverter must have symmetrical(negative and positive) voltage waveform and symmetrical current waveform (Unsymmetrical ratio is less than 10%). Please do not use the inverter which has unsymmetrical voltage and unsymmetrical current and spike wave.

Requirements for a system inverter design, which is intended to have a better display performance, a better power efficiency and a more reliable lamp, are following.

It shall help increase the lamp lifetime and reduce leakage current.

a. The asymmetry rate of the inverter waveform should be less than 10%.

b. The distortion rate of the waveform should be within $\sqrt{2} \pm 10\%$.

* Inverter output waveform had better be more similar to ideal sine wave.

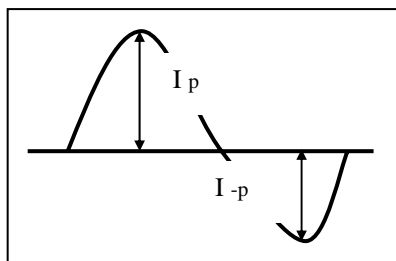

* Asymmetry rate:

$$|I_p - I_{-p}| / I_{rms} \times 100\%$$

* Distortion rate

$$I_p \text{ (or } I_{-p}) / I_{rms}$$

9. The inverter which is combined with this LCM, is highly recommended to connect coupling(ballast) condenser at the high voltage output side. When you use the inverter which has not coupling(ballast) condenser, it may cause abnormal lamp lighting because of biased mercury as time goes.

10. In case of edgy type back light with over 4 parallel lamps, input current and voltage wave form should be synchronized

Product Specification

3-2. Interface Connections

- LCD Connector(CN1) : FI-XB30SL-HF10 (Manufactured by JAE) or Equivalent
- Mating Connector : FI-X30C21 (Level type) or Equivalent.

Table 3. MODULE CONNECTOR(CN1) PIN CONFIGURATION

Pin No	Symbol	Description
1	GND	Ground
2	GND	Ground
3	RX2+	TMDS Low Voltage Differential Signal Input Data 2(+)
4	RX2-	TMDS Low Voltage Differential Signal Input Data 2(-)
5	GND	Ground
6	RX1+	TMDS Low Voltage Differential Signal Input Data 1(+)
7	RX1-	TMDS Low Voltage Differential Signal Input Data 1(-)
8	GND	Ground
9	RX0+	TMDS Low Voltage Differential Signal Input Data 0(+)
10	RX0-	TMDS Low Voltage Differential Signal Input Data 0(-)
11	GND	Ground
12	RXC+	TMDS Low Voltage Differential Signal Input Data C(+)
13	RXC-	TMDS Low Voltage Differential Signal Input Data C(-)
14	GND	Ground
15	VEDID	DDC Power Supply 3.3V
16	NC	NC
17	CLK-EDID	DDC Clock
18	DATA-EDID	DDC Data
19	GND	Ground
20	GND	Ground
21	GND	Ground
22	V _{LCD}	Power Supply 3.3V
23	V _{LCD}	Power Supply 3.3V
24	V _{LCD}	Power Supply 3.3V
25	POWER-ON	Power Control
26	HSYNC	Hsync Output
27	VSYNC	Vsync Output
28	GND	Ground
29	NC	NC, Reserved for HDCP
30	NC	NC, Reserved for HDCP

- Note:
1. All GND(ground) pins should be connected together and to V_{SS} which should also be connected to the LCD's metal frame.
 2. All V_{LCD} (power input) pins should be connected together.
 3. All NC pins should be separated from other signal or power.

Product Specification

User Connector Diagram

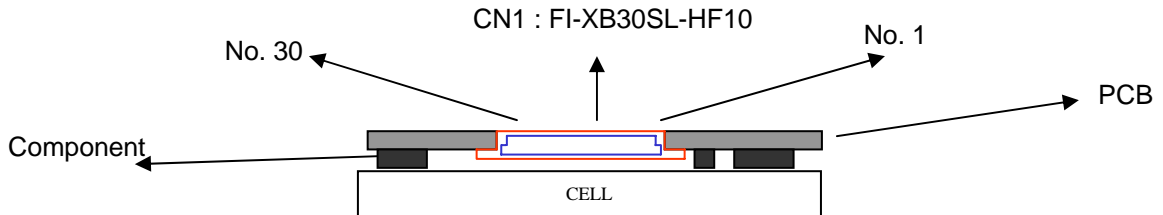
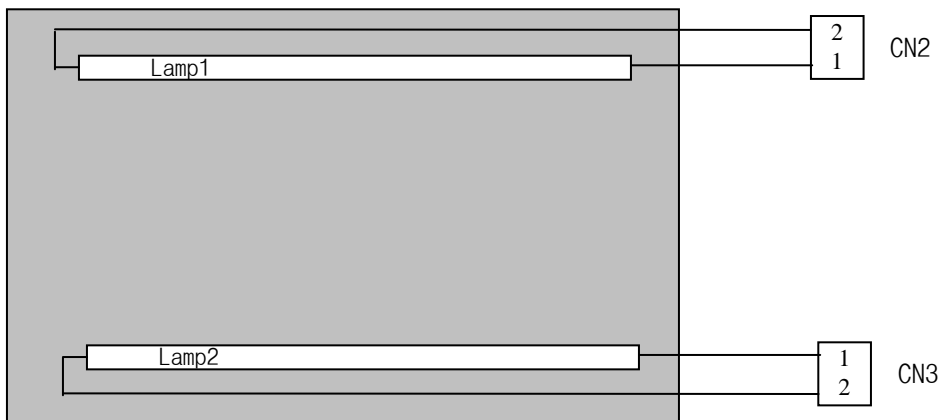

Table 4. BACKLIGHT CONNECTOR PIN CONFIGURATION (CN2,CN3)

Pin	Symbol	Description	Notes
1	HV	Power supply for lamp (high)	1) LCD : BHSR-02VS-1(JST)
2	LV	Power supply for lamp (Low)	2) System : SM02B-BHSS-1 (JST)

Notes : 1. The high voltage side terminal is colored Gray.
2. The low voltage side terminal is colored Black.



Product Specification

3-3. Signal Timing Specifications

This is the signal timing required at the input of the TMDS Transmitter. All of the interface signal timing should be satisfied with the following specifications for it's proper operation.

Table 5. Timing Table

ITEM	Symbol	Min	Typ	Max	Unit	Note
DCLK	Period	tCLK	9.17	9.17	9.17	ns
	Frequency	fCLK	109.05	109.05	109.05	MHz
Hsync	Period	tHP	2000	2000	2000	tCLK
	Width	tWH	32	32	32	tCLK
Vsync	Period	tVP	909	909	909	tHP
	Frequency	f _v	59.986	59.986	59.986	Hz
	Width	tWV	3	3	3	tHP
DE (Data Enable)	Horizontal Valid	tHV	1440	1440	1440	tCLK
	Horizontal Back Porch	tHBP	480	480	480	
	Horizontal Front Porch	tHFP	48	48	48	
	-	-	-	-	-	tHP
	Vertical Valid	tVV	900	900	900	
	Vertical Back Porch	tVBP	3	3	3	
	Vertical Front Porch	tVFP	3	3	3	
	-	-	-	-	-	

Note: Hsync period and Hsync width-active should be even number times of tCLK. If the value is odd number times of tCLK, display control signal can be asynchronous. In order to operate this LCM a Hsync, Vsync, and DE(data enable) signals should be used.

1. The performance of the electro-optical characteristics may be influenced by variance of the vertical refresh rates.
2. Vsync and Hsync should be keep the above specification.
3. Hsync Period, Hsync Width, and Horizontal Back Porch should be any times of of character number(8).
4. Vertical frequency is only 60Hz.

Product Specification

3-4. Signal Timing Waveforms

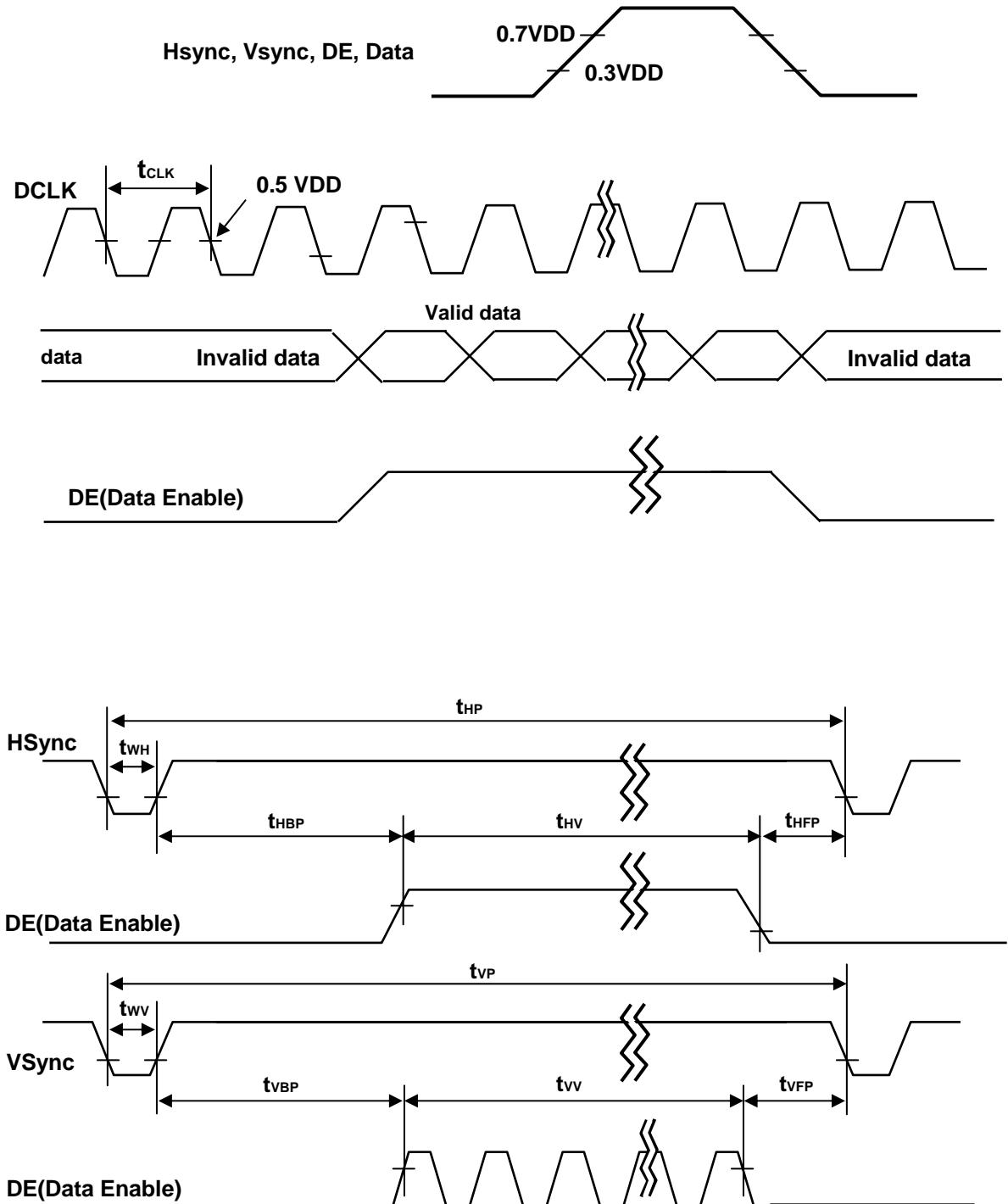

Product Specification

3-5. Color Data Reference

The Brightness of each primary color(red,green,blue) is based on the 6-bit gray scale data input for the color; the higher the binary input, the brighter the color. The table below provides a reference for color versus data input.

Table 6. COLOR DATA REFERENCE

Color		Input Color Data																	
		RED						GREEN						BLUE					
		MSB			LSB			MSB			LSB			MSB			LSB		
		R5	R4	R3	R2	R1	R0	G5	G4	G3	G2	G1	G0	B5	B4	B3	B2	B1	B0
Basic Color	Black	0	0	0	0	0	0	0	0	0	0	0	0	0	0	0	0	0	0
	Red (63)	1	1	1	1	1	1	0	0	0	0	0	0	0	0	0	0	0	0
	Green (63)	0	0	0	0	0	0	1	1	1	1	1	1	0	0	0	0	0	0
	Blue (63)	0	0	0	0	0	0	0	0	0	0	0	0	1	1	1	1	1	1
	Cyan	0	0	0	0	0	0	1	1	1	1	1	1	1	1	1	1	1	1
	Magenta	1	1	1	1	1	1	0	0	0	0	0	0	1	1	1	1	1	1
	Yellow	1	1	1	1	1	1	1	1	1	1	1	1	0	0	0	0	0	0
	White	1	1	1	1	1	1	1	1	1	1	1	1	1	1	1	1	1	1
RED	RED (00)	0	0	0	0	0	0	0	0	0	0	0	0	0	0	0	0	0	0
	RED (01)	0	0	0	0	0	1	0	0	0	0	0	0	0	0	0	0	0	0
					
	RED (62)	1	1	1	1	1	0	0	0	0	0	0	0	0	0	0	0	0	0
	RED (63)	1	1	1	1	1	1	0	0	0	0	0	0	0	0	0	0	0	0
GREEN	GREEN (00)	0	0	0	0	0	0	0	0	0	0	0	0	0	0	0	0	0	0
	GREEN (01)	0	0	0	0	0	0	0	0	0	0	0	1	0	0	0	0	0	0
					
	GREEN (62)	0	0	0	0	0	0	1	1	1	1	1	0	0	0	0	0	0	0
	GREEN (63)	0	0	0	0	0	0	1	1	1	1	1	1	0	0	0	0	0	0
BLUE	BLUE (00)	0	0	0	0	0	0	0	0	0	0	0	0	0	0	0	0	0	0
	BLUE (01)	0	0	0	0	0	0	0	0	0	0	0	0	0	0	0	0	0	1
					
	BLUE (62)	0	0	0	0	0	0	0	0	0	0	0	0	1	1	1	1	1	0
	BLUE (63)	0	0	0	0	0	0	0	0	0	0	0	0	1	1	1	1	1	1

Product Specification

3-6. Power Sequence

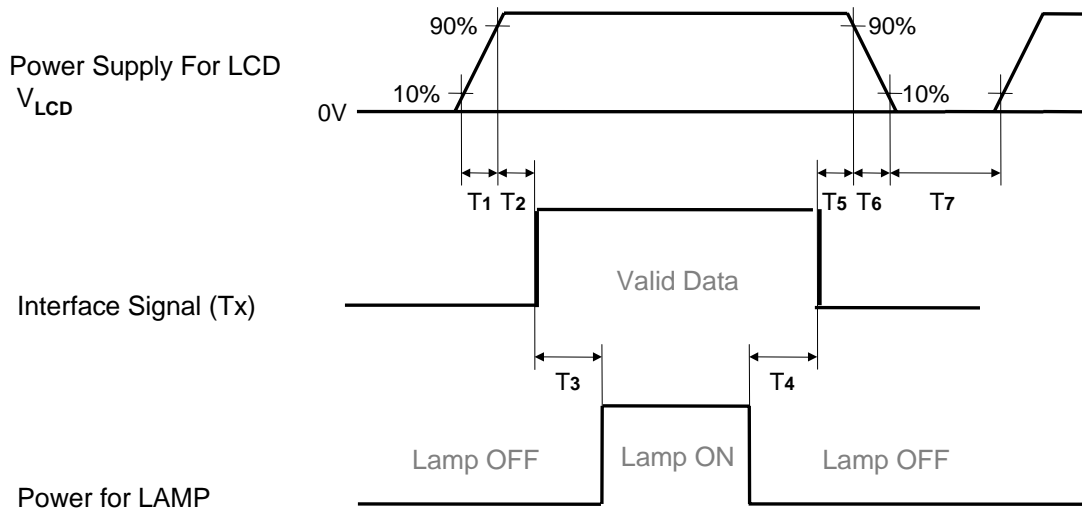

Table 7. POWER SEQUENCE

Parameter	Values			Units
	Min	Typ	Max	
T1	0.5	-	10	ms
T2	0.5	-	50	ms
T3	200	-	-	ms
T4	200	-	-	ms
T5	0.5	-	50	ms
T6	0.5	-	10	ms
T7	400	-	-	ms

- Notes :
1. Please avoid floating state of interface signal at invalid period.
 2. When the interface signal is invalid, be sure to pull down the power supply for LCD V_{LCD} to 0V.
 3. Lamp power must be turn on after power supply for LCD an interface signal are valid.

3-7. V_{LCD} Power Dip Condition

The V_{LCD} dip condition is caused by the PWM IC initialization.

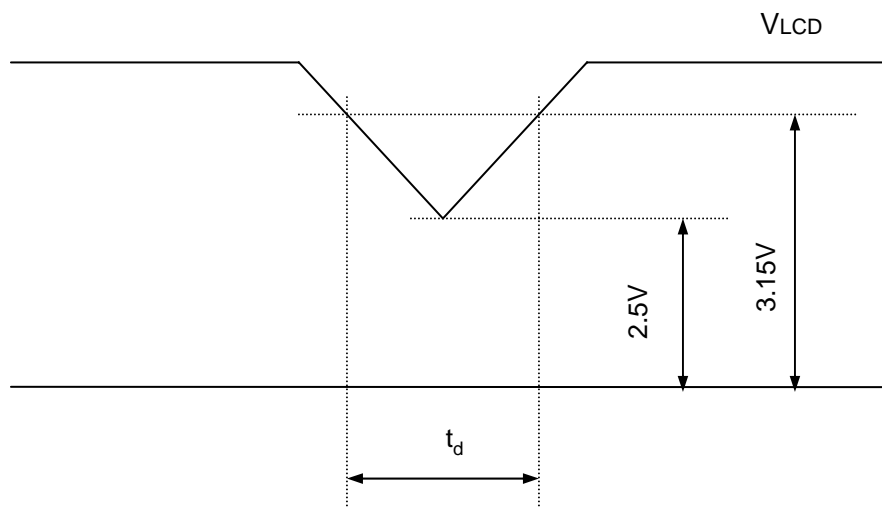

1) Dip condition

$$2.5V \leq V_{LCD} < 3.15V, t_d \leq 20ms$$

2) $V_{LCD} < 2.5V$

V_{LCD} -dip conditions should also follow the Power On/Off conditions for supply voltage.

Product Specification

4. Optical Specification

Optical characteristics are determined after the unit has been 'ON' and stable for approximately 30 minutes in a dark environment at $25 \pm 2^\circ\text{C}$. The values specified are at an approximate distance 50cm from the LCD surface at a viewing angle of Φ and θ equal to 0° .

FIG. 1 presents additional information concerning the measurement equipment and method.

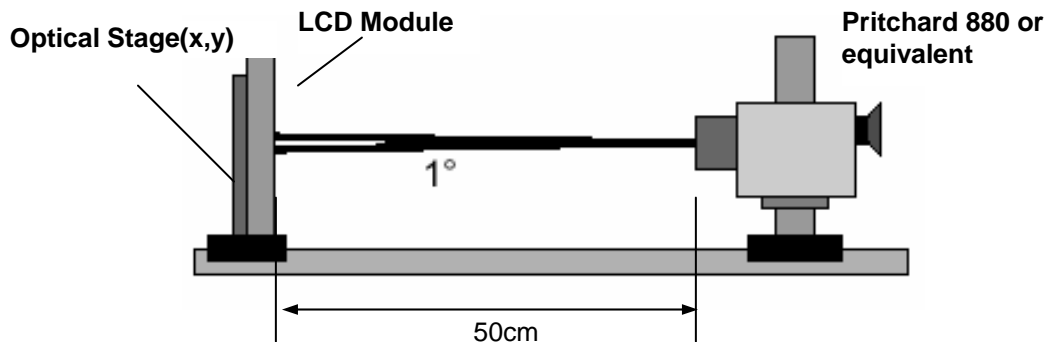

FIG. 1 Optical Characteristic Measurement Equipment and Method

Table 7. OPTICAL CHARACTERISTICS

$T_a = 25 \pm 2^\circ\text{C}$, $V_{LCD} = 3.3\text{V}$, $f_v = 60\text{Hz}$, $D_{clk} = 109.05\text{MHz}$, $I_{Lamp} = 8\text{mA}$

Parameter	Symbol	Values			Units	Notes	
		Min	Typ	Max			
Contrast Ratio	CR	450	550	-		1	
Surface Luminance, white	L_{WH}	200	250	-	cd/m^2	2	
Luminance Variation	δ_{WHITE} 9P	-	30	40	%	3	
Response Time	Rise Time	Tr_R	-	5	10	ms	4
	Decay Time	Tr_D	-	11	16	ms	
Color Coordinates [CIE1931]	RED	R_x	Typ -0.03	0.631	Typ +0.03		
		R_y		0.347			
	GREEN	G_x		0.306			
		G_y		0.590			
	BLUE	B_x		0.150			
		B_y		0.088			
	WHITE	W_x		0.313			
	W_y	0.329					
Viewing Angle (CR>10)							
	x axis, right($\phi=0^\circ$)	θ_r	60	70	-	degree	5
	x axis, left ($\phi=180^\circ$)	θ_l	60	70	-		
	y axis, up ($\phi=90^\circ$)	θ_u	50	60	-		
	y axis, down ($\phi=270^\circ$)	θ_d	50	60	-		
Gray Scale			-	-	-		6

Product Specification

Notes 1. Contrast Ratio(CR) is defined mathematically as :

$$\text{Contrast Ratio} = \frac{\text{Surface Luminance with all white pixels}}{\text{Surface Luminance with all black pixels}} \text{ at center point (1)}$$

2. Surface luminance is luminance value at center point(1) across the LCD surface 50cm from the surface with all pixels displaying white. For more information see FIG 2.

3. The variation in surface luminance , δ WHITE is defined as :

$$\delta \text{ WHITE}(9P) = \text{Maximum}(L_{on1}, L_{on2}, L_{on3}, \dots, L_{on9}) / \text{Minimum}(L_{on1}, L_{on2}, L_{on3}, \dots, L_{on9})$$

Where L_{on1} to L_{on9} are the luminance with all pixels displaying white at 9 locations .

For more information see FIG 2.

4. Response time is the time required for the display to transition from white to black(Rise Time, Tr_R) and from black to white(Decay Time, Tr_D). For additional information see FIG 3.

5. Viewing angle is the angle at which the contrast ratio is greater than 10. The angles are determined for the horizontal or x axis and the vertical or y axis with respect to the z axis which is normal to the LCD surface. For more information see FIG 4.

6. Gray scale specification.

Table 8. Gray Scale Specification

Gray Level	Luminance [%] (Typ)
L0	0.17
L3	0.22
L7	0.51
L11	1.51
L15	3.39
L19	6.34
L23	10.0
L27	14.8
L31	20.0
L35	26.1
L39	33.1
L43	41.1
L47	50.5
L51	61.1
L55	72.2
L59	86.1
L63	100

Product Specification

Measuring point for surface luminance & measuring point for luminance variation

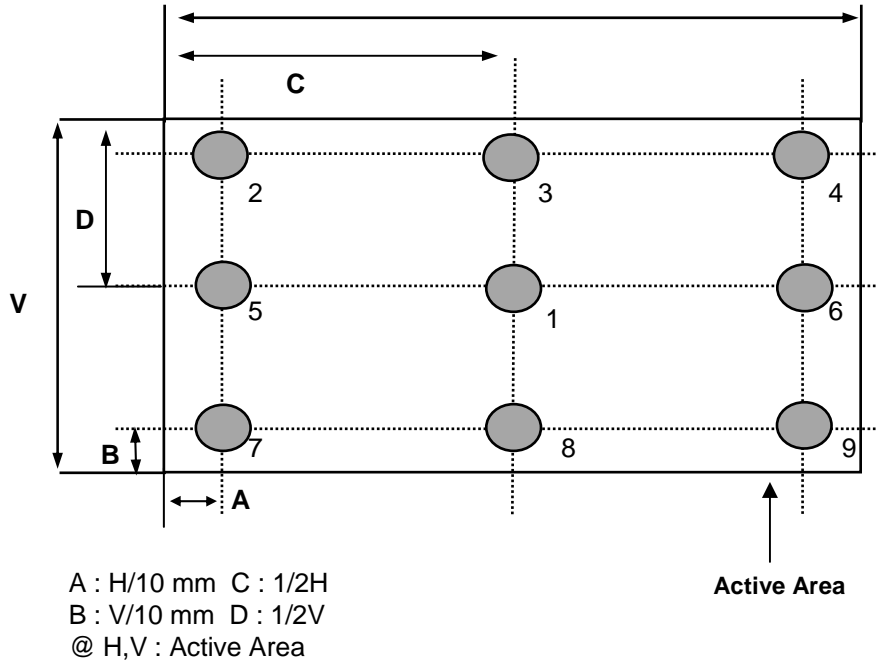

FIG. 2 Measure Point for Luminance

The response time is defined as the following figure and shall be measured by switching the input signal for “black” and “white”.

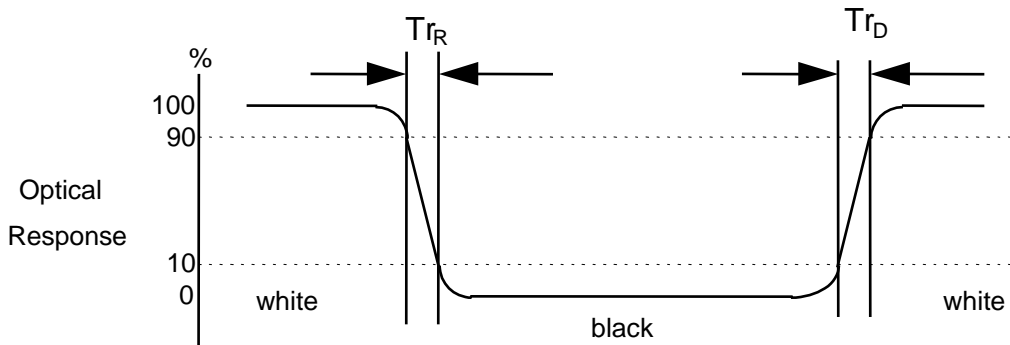

FIG. 3 Response Time

Product Specification

Dimension of viewing angle range

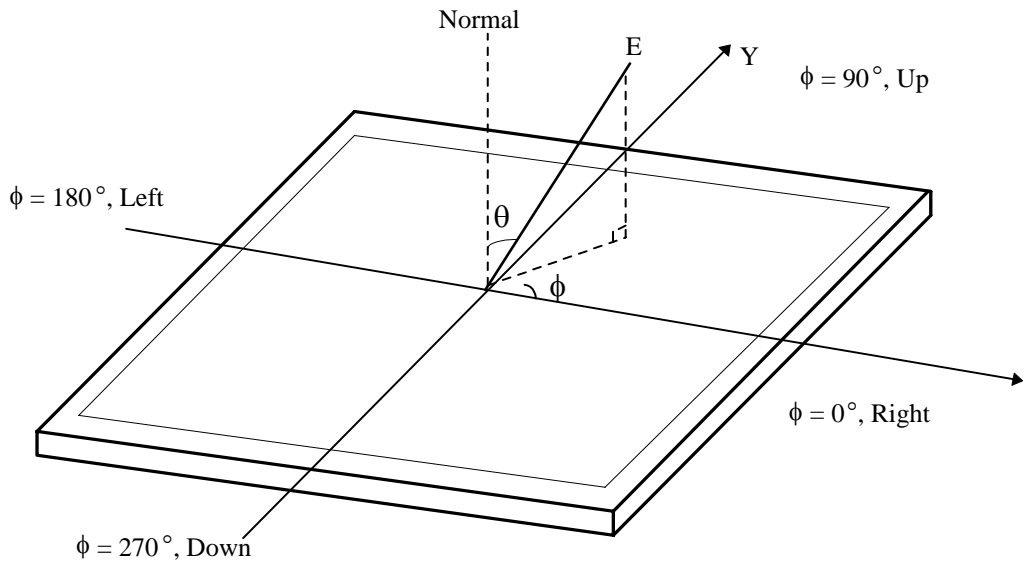

FIG. 4 Viewing angle

Product Specification

5. Mechanical Characteristics

The contents provide general mechanical characteristics. In addition the figures in the next page are detailed mechanical drawing of the LCD.

Outline Dimension	Horizontal	395mm
	Vertical	256.4mm
	Depth	11.0mm
Bezel Area	Horizontal	371.2 mm
	Vertical	233.6 mm
Active Display Area	Horizontal	367.2mm
	Vertical	229.5mm
Weight	1,220 g(Typ.), 1,250 g(Max.)	
Surface Treatment	Hard coating(3H) Anti-glare(12%) treatment of the front polarizer	

Notes : Please refer to a mechanic drawing in terms of tolerance at the next page.

Product Specification

<FRONT VIEW>

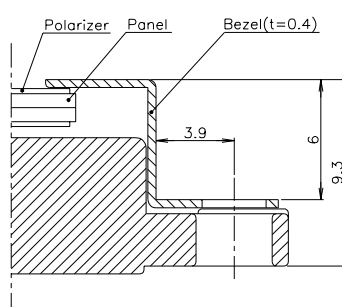
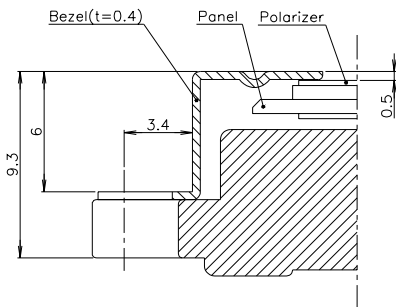
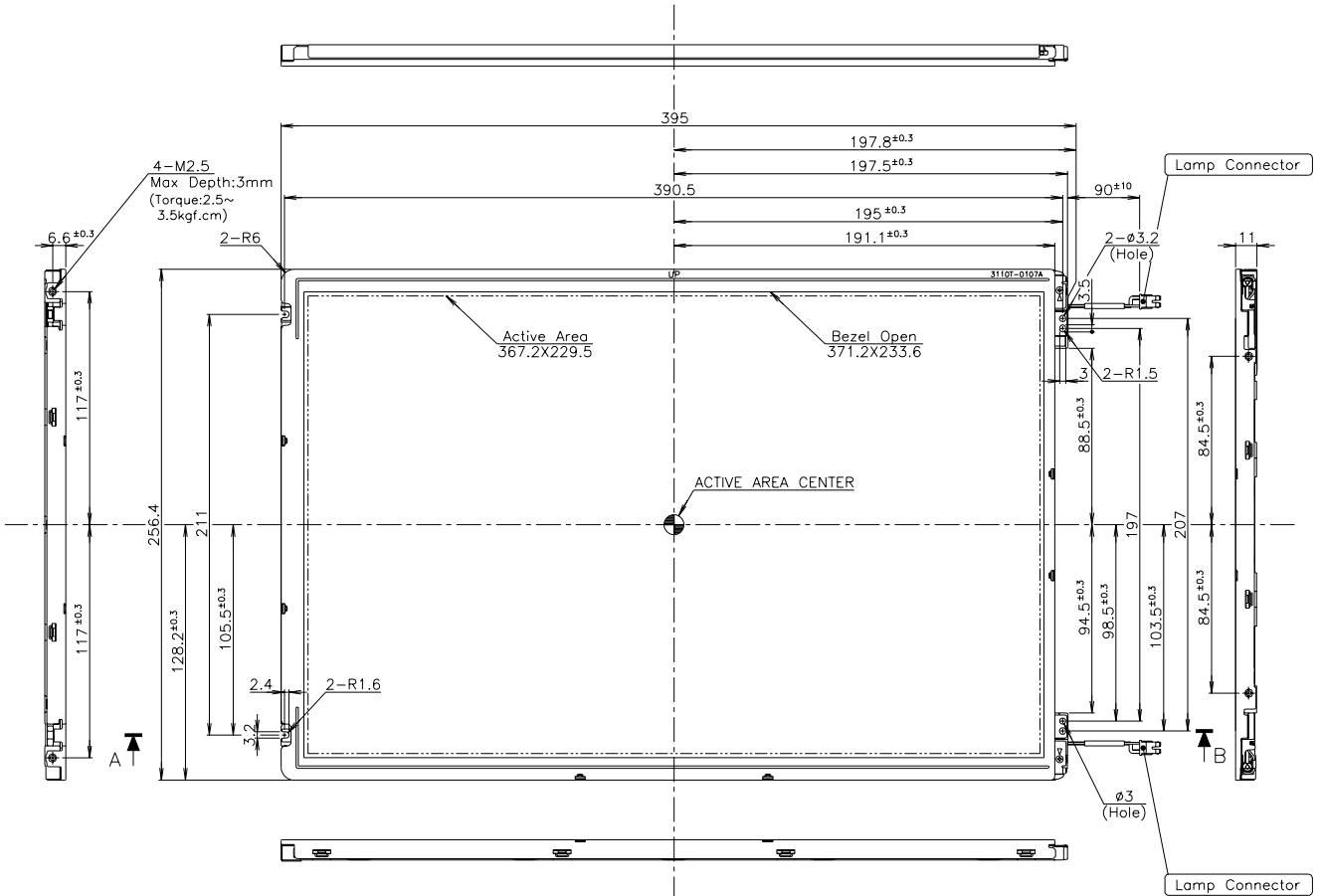

Product Specification

<REAR VIEW>

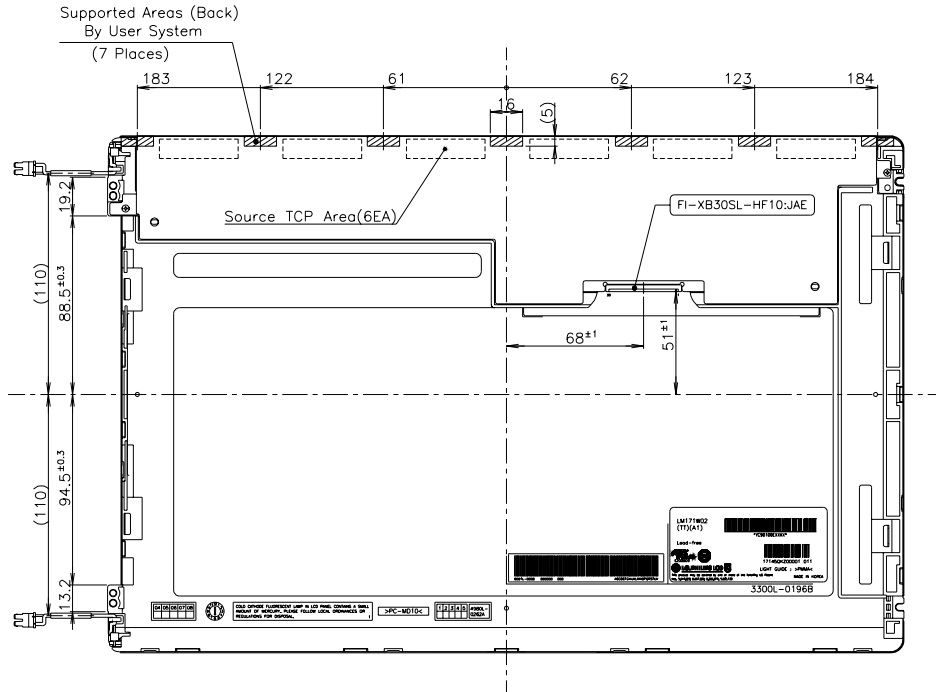

NOTES

1. Backlight : 2 Cold Cathode Fluorescent Lamps.
2. Lamp Connector Specification.
- JST BHSR-02VS-1.
3. Gap between Bezel and Panel : Max 0.6mm.
4. Source TCP area is weak and sensitive. So, Please don't press the TCP area.
5. Tilt and partial disposition tolerance of display area as following.
(1) Y-Direction : $|A-B| \leq 1.0$
(2) X-Direction : $|C-D| \leq 1.0$

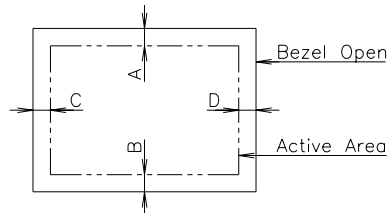

6. Lamp(CCFL) lot No. is marked at backlight connector.

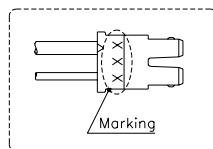

7. Do not wind conductive tape around the backlight wires.
8. Unspecified tolerances to be $\pm 0.5\text{mm}$.

Product Specification

6. Reliability

Environment test condition

No	Test Item	Condition
1	High temperature storage test	Ta= 60°C 240h
2	Low temperature storage test	Ta= -20°C 240h
3	High temperature operation test	Ta= 50°C 50%RH 240h
4	Low temperature operation test	Ta= 0°C 240h
5	Vibration test (non-operating)	Wave form : random Vibration level : 1.0G RMS Bandwidth : 10-500Hz Duration : X,Y,Z, 20 min One time each direction
6	Shock test (non-operating)	Shock level : 120G Waveform : half sine wave, 2ms Direction : ±X, ±Y, ±Z One time each direction
7	Altitude operating storage / shipment	0 - 10,000 feet(3048m) 0 - 40,000 feet(12,192m)

7. International Standards

7-1. Safety

- a) UL 60950, Third Edition, Underwriters Laboratories, Inc., Dated Dec. 11, 2000.
Standard for Safety of Information Technology Equipment, Including Electrical Business Equipment.
- b) CAN/CSA C22.2, No. 60950, Third Edition, Canadian Standards Association, Dec. 1, 2000.
Standard for Safety of Information Technology Equipment, Including Electrical Business Equipment.
- c) EN 60950 : 2000, Third Edition
IEC 60950 : 1999, Third Edition
European Committee for Electrotechnical Standardization(CENELEC)
EUROPEAN STANDARD for Safety of Information Technology Equipment Including Electrical Business Equipment.

7-2. EMC

- a) ANSI C63.4 "Methods of Measurement of Radio-Noise Emissions from Low-Voltage Electrical and Electrical Equipment in the Range of 9kHz to 40GHz. "American National Standards Institute(ANSI), 1992
- b) C.I.S.P.R "Limits and Methods of Measurement of Radio Interface Characteristics of Information Technology Equipment." International Special Committee on Radio Interference.
- c) EN 55022 "Limits and Methods of Measurement of Radio Interface Characteristics of Information Technology Equipment." European Committee for Electrotechnical Standardization.(CENELEC), 1998 (Including A1: 2000)

Product Specification

8. Packing

8-1. Designation of Lot Mark

a) Lot Mark

A	B	C	D	E	F	G	H	I	J	K	L	M
---	---	---	---	---	---	---	---	---	---	---	---	---

A,B,C : SIZE(INCH)

E : MONTH

G : ASSEMBLY CODE

D : YEAR

F : FACTORY CODE

H, I, J, K, L, M : SERIAL NO.

Note

1. YEAR

Year	2001	2002	2003	2004	2005	2006	2007	2008	2009	2010
Mark	1	2	3	4	5	6	7	8	9	0

2. MONTH

Month	Jan	Feb	Mar	Apr	May	Jun	Jul	Aug	Sep	Oct	Nov	Dec
Mark	1	2	3	4	5	6	7	8	9	A	B	C

3. FACTORY CODE

Factory Code	LPL Gumi	LPL Nanjing	HEESUNG
Mark	K	C	D

4. SERIAL NO.

Mark	100001~199999, 200001~299999, 300001~399999,, A00001~A99999,, Z00001~Z99999
------	---

b) Location of Lot Mark

Serial No. is printed on the label. The label is attached to the backside of the LCD module.

This is subject to change without prior notice.

8-2. Packing Form

a) Package quantity in one box : 10 pcs

b) Box size : 355mm X 344mm X 449mm.

Product Specification

9. PRECAUTIONS

Please pay attention to the followings when you use this TFT LCD module.

9-1. MOUNTING PRECAUTIONS

- (1) You must mount a module using holes arranged in four corners or four sides.
- (2) You should consider the mounting structure so that uneven force (ex. Twisted stress) is not applied to the module. And the case on which a module is mounted should have sufficient strength so that external force is not transmitted directly to the module.
- (3) Please attach the surface transparent protective plate to the surface in order to protect the polarizer. Transparent protective plate should have sufficient strength in order to resist external force.
- (4) You should adopt radiation structure to satisfy the temperature specification.
- (5) Acetic acid type and chlorine type materials for the cover case are not desirable because the former generates corrosive gas of attacking the polarizer at high temperature and the latter causes circuit break by electro-chemical reaction.
- (6) Do not touch, push or rub the exposed polarizers with glass, tweezers or anything harder than HB pencil lead. And please do not rub with dust clothes with chemical treatment. Do not touch the surface of polarizer for bare hand or greasy cloth.(Some cosmetics are detrimental to the polarizer.)
- (7) When the surface becomes dusty, please wipe gently with absorbent cotton or other soft materials like chamois soaks with petroleum benzene. Normal-hexane is recommended for cleaning the adhesives used to attach front / rear polarizers. Do not use acetone, toluene and alcohol because they cause chemical damage to the polarizer.
- (8) Wipe off saliva or water drops as soon as possible. Their long time contact with polarizer causes deformations and color fading.
- (9) Do not open the case because inside circuits do not have sufficient strength.

9-2. OPERATING PRECAUTIONS

- (1) The spike noise causes the mis-operation of circuits. It should be lower than following voltage :
 $V = \pm 200\text{mV}$ (Over and under shoot voltage)
- (2) Response time depends on the temperature.(In lower temperature, it becomes longer.)
- (3) Brightness depends on the temperature. (In lower temperature, it becomes lower.)
And in lower temperature, response time(required time that brightness is stable after turned on) becomes longer.
- (4) Be careful for condensation at sudden temperature change. Condensation makes damage to polarizer or electrical contacted parts. And after fading condensation, smear or spot will occur.
- (5) When fixed patterns are displayed for a long time, remnant image is likely to occur.
- (6) Module has high frequency circuits. Sufficient suppression to the electromagnetic interference shall be done by system manufacturers. Grounding and shielding methods may be important to minimize the interference.
- (7) Please do not give any mechanical and/or acoustical impact to LCM. Otherwise, LCM can not be operated its full characteristics perfectly.
- (8) A screw which is fastened up the steels should be a machine screw (if not, it causes metallic foreign material and deal LCM a fatal blow)
- (9) Please do not set LCD on its edge.

Product Specification

9-3. ELECTROSTATIC DISCHARGE CONTROL

Since a module is composed of electronic circuits, it is not strong to electrostatic discharge. Make certain that treatment persons are connected to ground through wrist band etc. And don't touch interface pin directly.

9-4. PRECAUTIONS FOR STRONG LIGHT EXPOSURE

Strong light exposure causes degradation of polarizer and color filter.

9-5. STORAGE

When storing modules as spares for a long time, the following precautions are necessary.

- (1) Store them in a dark place. Do not expose the module to sunlight or fluorescent light. Keep the temperature between 5°C and 35°C at normal humidity.
- (2) The polarizer surface should not come in contact with any other object.
It is recommended that they be stored in the container in which they were shipped.

9-6. HANDLING PRECAUTIONS FOR PROTECTION FILM

- (1) The protection film is attached to the bezel with a small masking tape.
When the protection film is peeled off, static electricity is generated between the film and polarizer. This should be peeled off slowly and carefully by people who are electrically grounded and with well ion-blown equipment or in such a condition, etc.
- (2) When the module with protection film attached is stored for a long time, sometimes there remains a very small amount of glue still on the bezel after the protection film is peeled off.
- (3) You can remove the glue easily. When the glue remains on the bezel surface or its vestige is recognized, please wipe them off with absorbent cotton waste or other soft material like chamois soaked with normal-hexane.