

AGP-3155

15" Rugged Touch Panel Computer With Intel® Core™ i7/i5 Processor

03

Rugged Expandable Touch Panel Solutions

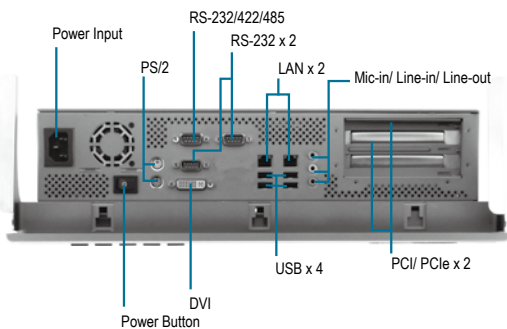
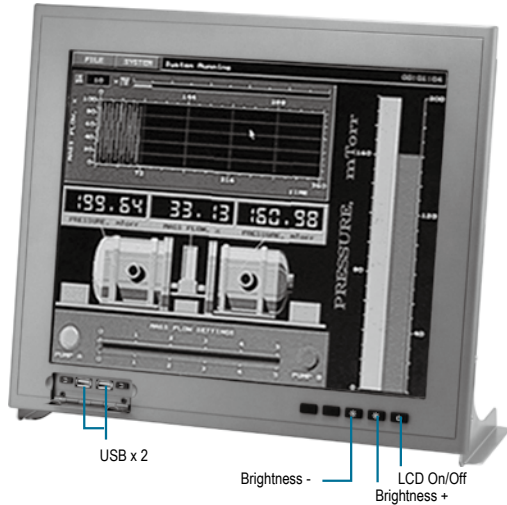

Features

- 15" XGA (1024 x 768) TFT LCD Display
- Intel® Core™ i7/i5 Processor
- Easy-To-Expand: Two PCI/PCIe Slots
- IP-65 Aluminum Die Cast Front Bezel
- Two Easy Access Front USB Ports
- 15" 250 Nits XGA CCFL Backlight
15" 800 Nits XGA LED Backlight
- Modular Design For CPU Board



Specifications

System	
Processor	Intel® Core™ i7/i5 Processor
Memory	DDR3 800/1066MHz SODIMM x 2, up to 8 GB
Chipset	Intel® Core™ i7/i5 + QM57
LCD/CRT Controller	Integrated in Intel® QM57
Ethernet	10/100/1000Base-TX, RJ-45 x 2
I/O Port	RS-232 x 2, RS-232/422/485 x 1, USB2.0 x 6 (2 on front, 4 on rear), Line-out/MIC-in/Line-in x 1, PS/2x1 for KB/Mouse, DVI x 1
Storage Disk Drive	3.5" SATA Hard Disk Drive x 2, Slim DVD-Combo (optional)
Expansion Slot	Mini card x 1, PCI slot x 2 or PCIe x 2
OS Support	Windows® XP, Windows® 7, Linux Fedora
Mechanical	
Construction	IP-65/ NEMA4 for aluminum die cast front bezel & Aluminum chassis
Mounting	Panel/ Desktop
Dimension	15.36" x 12.76" x 4.91" (390mm x 324mm x 124.7mm)
Carton Dimension	—
Gross Weight	—
Net Weight	—
Environmental	
Operating Temperature	32°F ~ 131°F (0°C ~ 55°C) (Ambient with Airflow)
Storage Temperature	-4°F ~ 140°F (-20°C ~ 60°C)
Storage Humidity	10%~95% @ 40°C, non-condensing
Vibration	1 g rms/ 5~500Hz/ Random operation (HDD)
Shock	15 G peak acceleration (11 msec. Duration)
EMC	CE/FCC Class A
Power Supply	
AC input 250W	110/230V AC power
LCD	
Display type	15" TFT-LCD
Max Resolution	1024 x 768
Max. Colors	16.7M colors (6/8-bit for R,G,B)
Luminance	HTT : 250, STT : 800
Viewing Angle	HTT : 170°(H)/160°(V), STT : 160°(H)/140°(V)
Back Light	HTT: CCFL, STT: LED
Back Light MTBF (hours)	HTT:30,000, STT: 60,000
Touchscreen	
Type	5-wire resistive
Light Transmission	80%
Lifetime (times)	35 Million activations

AGP-3155

Dimension

Unit: mm

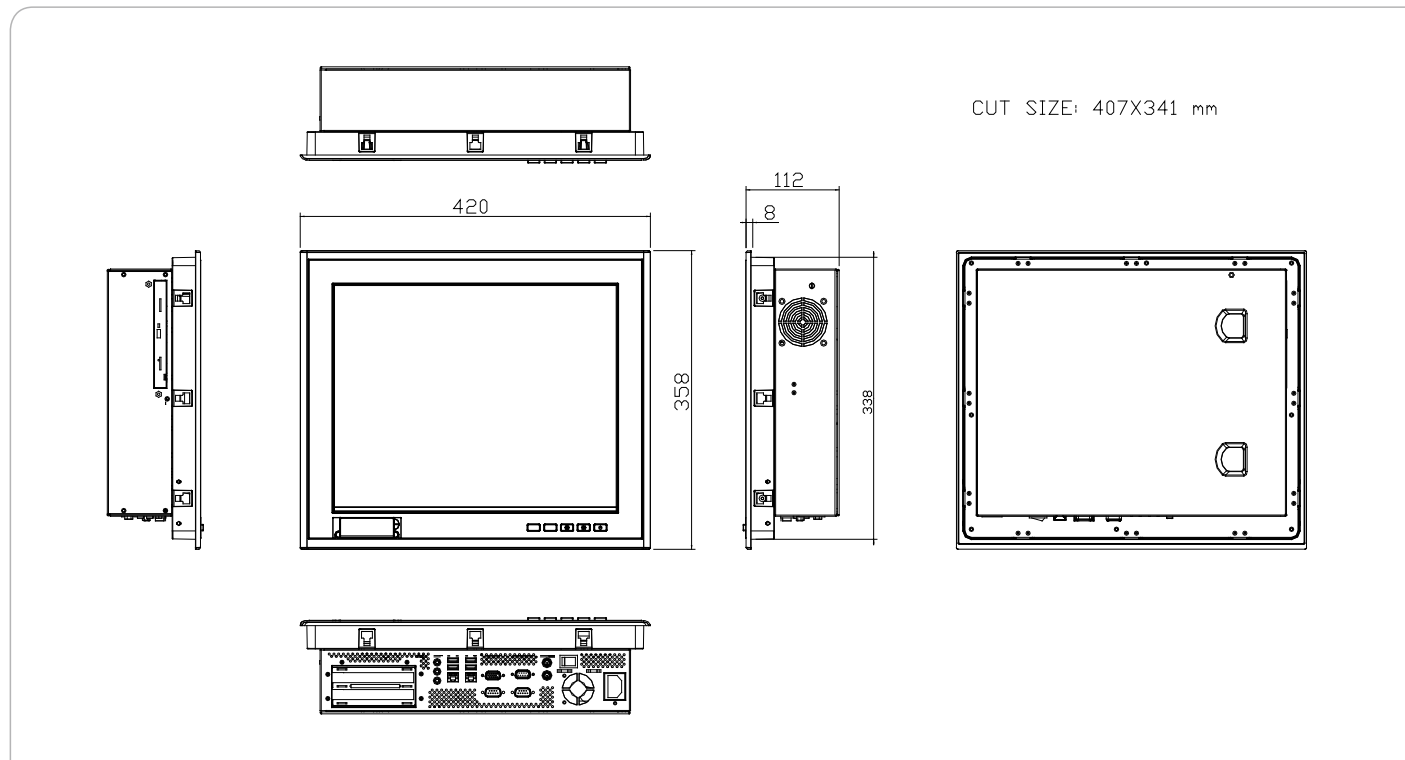

Ordering Information

- **TF-AGP-3155HTT-A1-1010**
15" Rugged Touch Panel Computer with Intel® Core™ i7/i5, 2 PCI Slots, 250 Nits
- **TF-AGP-3155HTT-A2-1010**
15" Rugged Touch Panel Computer with Intel® Core™ i7/i5, 2 PCI Slots, 250 Nits
- **TF-AGP-3155STT-A1-1010**
15" Rugged Touch Panel Computer with Intel® Core™ i7/i5, 2 PCI Slots, 800 Nits
- **TF-AGP-3155STT-A2-1010**
15" Rugged Touch Panel Computer with Intel® Core™ i7/i5, 2 PCI Slots, 800 Nits

Optional Accessories

- **Desktop Stand**
- **1702031802**
Power Cord (US Type)
- **1702031803**
Power Cord (European Type)
- **170203180E**
Power Cord (Japanese Type)
- **WiFi Module (Mini Card)**
- **WiFi Antenna**
- **DVD-Combo Kit**