



Maintenance-Free Rechargeable Sealed Lead-Acid Battery



BPL28-12

The battery is constructed by plates, separators, safety valves and container. Since the electrolyte is held by a glass-mat separator and plates, the battery can use in any direction and position without leakage.

PERFORMANCE SPECIFICATIONS

Nominal Voltage(V).....	12 volts(6cells in series)
Nominal Capacity(AH)	
20 Hour rate F.V.(1.75V/cell) (1400mA to 10.5volts)	28.0A.H.
10 Hour rate F.V.(1.75V/cell) (2660mA to 10.5volts).....	26.6A.H.
5 Hour rate F.V.(1.75V/cell) (4760mA to 10.5volts)	23.8A.H.
30 Min rate F.V.(1.30V/cell) (28000mA to 7.80volts).....	14.0A.H.
Approximate Weight.....	9700g(21.39lbs.)
Terminal	
Standard.....	Type B1
Optional.....	Type T2.I1
Internal Resistance (Fully Charged Battery).....	<10m Ω
Maximum Discharge Current For 5 sec.(A).....	420A
Maximum Charge Current(A).....	8.4A
Ambient Temperature	
Charge.....	0°C(32°F)~40°C(104°F)
Discharge.....	-20°C(-4°F)~50°C(122°F)
Storage.....	-20°C(-4°F)~40°C(104°F)
Vibration test:	
Frequency: 16.7HZ	
Amplitude: 4mm	
Vibrate the battery horizontally or vertically for 60 minutes. The battery have no abnormality.	
Design Life:10 years for standby use at 20°C	
Case.....	ABS
Dimension(mm/inch)	
Length ±1.5mm.....	175/6.89
Width ±1.5mm.....	166/6.54
Container Height ±1.5mm.....	125/4.92
Total Height ±1.5mm.....	125/4.92
Application.....	Wheelchairs, Lawn Mowers, Electronic Medical Equipment, Golf-Carts.

BPL28-12 Battery discharge characteristics (25 °C/77 °F)

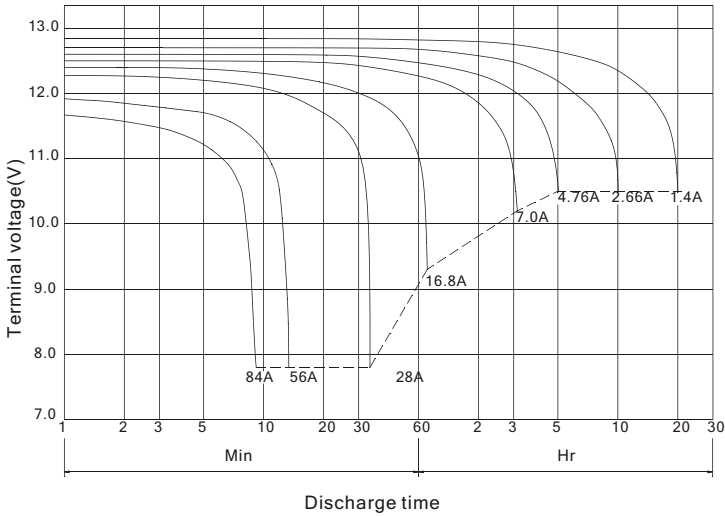

BATTERY CHARGING CHARACTERISTICS

(Typical example of charge characteristic for the standby use)

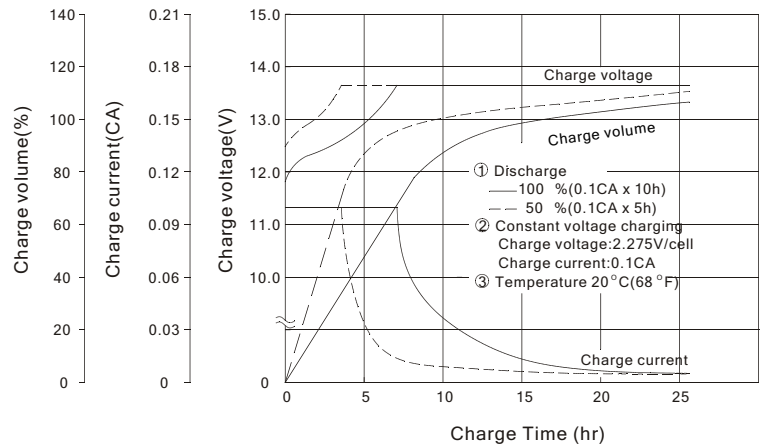

Charging Procedure

Application	Charging method	Charging Voltage at 20 °C (V/cell)	Temperature compensation coefficient of charging voltage (mV/°C/cell)	Max. charging current (CA)	Charging time 0.1CA, 20 °C (h)		Temp (°C)
					100% discharge	50% discharge	
For standby power source	Constant voltage & Constant current charging (with current restriction)	2.25~2.30	-3	0.3	24	20	0~40 (32~104°F)
For cycle service		2.40~2.50	-4	0.3	16	10	

*Temperature compensation of charging voltage is not needed, when using the batteries within 5 °C to 35 °C range.

Battery Life Characteristics of Cyclic Use

Testing Conditions : Discharge Current : 0.25C Amp (F.V. 1.7V/cell)
 Charging Current : 0.1C Amp
 Charging Voltage : 120% OF Discharge Capacity
 Ambient Temperature : 20 °C (68 °F)

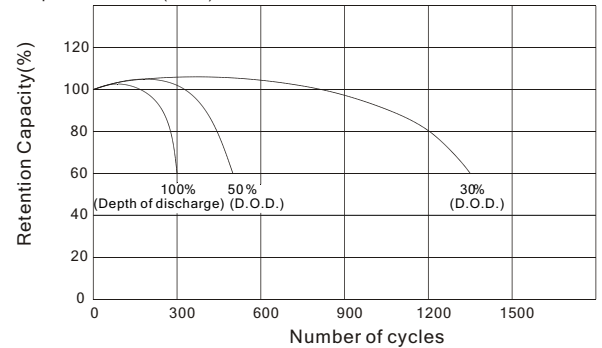

OUTER DIMENSIONS

mm (inch)

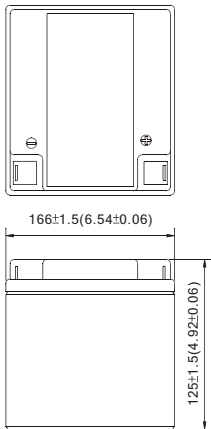

TERMINAL TYPE

mm (inch)

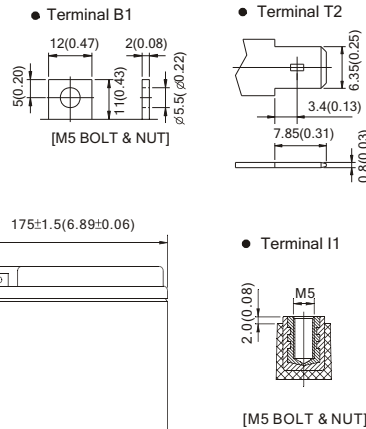

Constant power discharge characteristics at 25°C/77°F

Final Voltage	Discharge time								
	5Min	10Min	15Min	30Min	1Hr	3Hr	5Hr	10Hr	20Hr
10.80V	912	685.6	555.2	334.0	193.6	81.6	56.4	31.44	16.44
10.50V	1056	742.8	581.2	346.8	199.2	83.2	57.2	31.92	16.80
10.20V	1120	769.6	598.8	354.4	202.8	84.0	57.6	32.08	16.88
9.90V	1172	788.0	612.8	359.6	205.6	84.8	58.0	32.16	16.92
9.60V	1208	803.6	624.8	363.2	207.6	85.2	58.0	32.16	16.92

TERMINAL POSITION

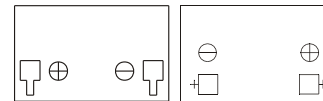

B.B. BATTERY CO., LTD.

Web Site: <http://www.bb-battery.com>

USA:
 B&B BATTERY(USA) INC.
 6415 RANDOLPH ST.COMMERCE,
 CA,90040 U.S.A.
 TEL.:1-323-278-1900.1-800-278-8599
 FAX:1-323-278-1268
 E-Mail:sales@bb-battery.com

EUROPE:
 B&B BATTERY(EUROPE) B.V.
 3 WIJNGAARDVELD, 9300 AALST,BELGIUM
 TEL:(00)32-53781567
 FAX:(00)32-53781567
 E-Mail:hansdevriese@bb-battery.com

CHINA FACTORY:
 B.B. BATTERY CO., LTD.
 CHENG DONG TRIAL AREA,HUANG GANG,
 RAOPING, GUANG DONG,CHINA,515700
 TEL:86-768-7601001-2
 FAX:86-768-7601469
 E-Mail:maggy@bb-battery.com

HONG KONG:
 NATIONAL TRADING LTD.
 TEL:852-2301-3800
 FAX:852-2739-1182
 E-Mail:bbhk@hkstar.com

JAPAN:
 B&B BATTERY(JAPAN) CO., LTD.
 1375-11 NARAHARA-MACHI,HACHIOJI,
 TOKYO 193-0803,JAPAN.
 TEL:81-426-256-537
 FAX:81-426-256-537
 E-Mail:miyata@bb-battery.com

TAIWAN:
 B.B. BATTERY(TAIWAN) CO., LTD.
 TEL:886-6-502-5150
 FAX:886-6-589-8087
 E-Mail:maggy@bb-battery.com

