



# DS8100

## High Performance Laser Scanner

### Features

- **ASTRA™** technology with multi-laser and fixed optic architecture
- 1,000 mm (40 in) depth of field on high resolution codes
- Very high scan rate: up to 2,000 scans/sec
- Integrated **PackTrack™** for gap reduction between 2 parcels
- **TBS™** technology for bar code reading under plastic film
- **WINHOST™** and **VOYAGER™** software packages
- High performance software programmable oscillating mirror

### Applications

- Parcel sorting system
- Postal applications
- Automatic baggage handling
- Cargo applications
- Loading/unloading systems

### General Description

Datalogic patented technologies, innovations and top performance are the main features of the new **DS8100**, the most powerful bar code reader on the market.

The **DS8100** scanner has been designed to offer the best performance and advanced solutions for the most demanding applications in the Material Handling and Sorting Systems fields.

The omni-directional reading stations based on **DS8100** read medium/high density codes on very fast conveyors with a very large reading area and a minimum gap of 50 mm (2 in) between 2 parcels.

The exclusive **ASTRA™** technology (Automatically SwiTched Reading Area) sets a new standard for reading performance. Based on a multi-laser architecture and without a mechanical focusing system, **ASTRA™** unites the reading performance of many independent readers in just one scanner, providing reliability and durability benefits.

Successful and proven **ACR™** technology is combined with **PackTrack™** to reduce the distance between two objects and increase the system throughput. The **DS8100**, fitted with the Datalogic patented **TBS™** system, also provides almost a 100% read rate on codes covered by plastic film. Other features include high speed integrated oscillating mirror models programmable through the standard software.

With the innovative **DS8100**, Datalogic sets a new standard for Industrial AUTO-ID.

---

## Technologies

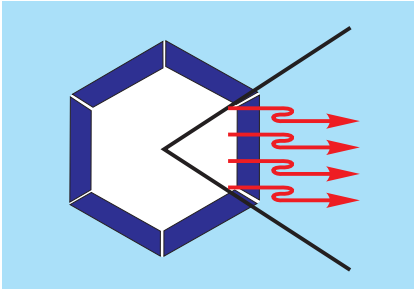

**ASTRA™** (Automatically SwiTched Reading Area) is the Datalogic patented solution to a fundamental need in the Material Handling sector: to read medium-high density bar codes in a large reading area on very fast conveyors.

In order to increase the processes' throughputs, today's conveyors go faster and faster, while the distance between two objects becomes shorter and shorter.

Following this technological trend, the conveyor systems must be fitted with Auto-ID equipment able to read simultaneously ( in the same scan line) two bar code labels placed, for instance, on two parcels with different heights.

This need is not compatible with bar code readers based on dynamic or mechanical focusing systems that, with more than a 20 msec focus setting time, cannot read bar code labels placed at different distances simultaneously.

A fixed mounted optic lens and the elimination of any kind of mechanical focusing systems allows **ASTRA™** technology to completely overcome today's limitations. **ASTRA™** technology offers a depth of field of 1,000 mm (40 in) on 0.3 mm (0.12 in) resolution codes, and a depth of field of 1,500 mm (60 in) on 0.5 mm (0.20 in) resolution codes.

**ASTRA™** is based on a multi-laser architecture and a fixed mounted optic system that concentrates the multiple laser emissions in a single laser beam, increasing the reading capability of a single scanner and providing an extended depth of field. Each laser emitter is focused on a specific range of the reading area and selected by means of a sophisticated electronic controller based on the actual position of the code to be read.

The **ASTRA™** system puts together, in just one scanner, the reading performance of many readers, with many benefits not only in performance but also in terms of reliability and durability.

By using fixed mounted optics and avoiding moving lens or mechanical focusing systems, **ASTRA™** supports high mechanical vibrations and doesn't need periodical and frequent maintenance service.

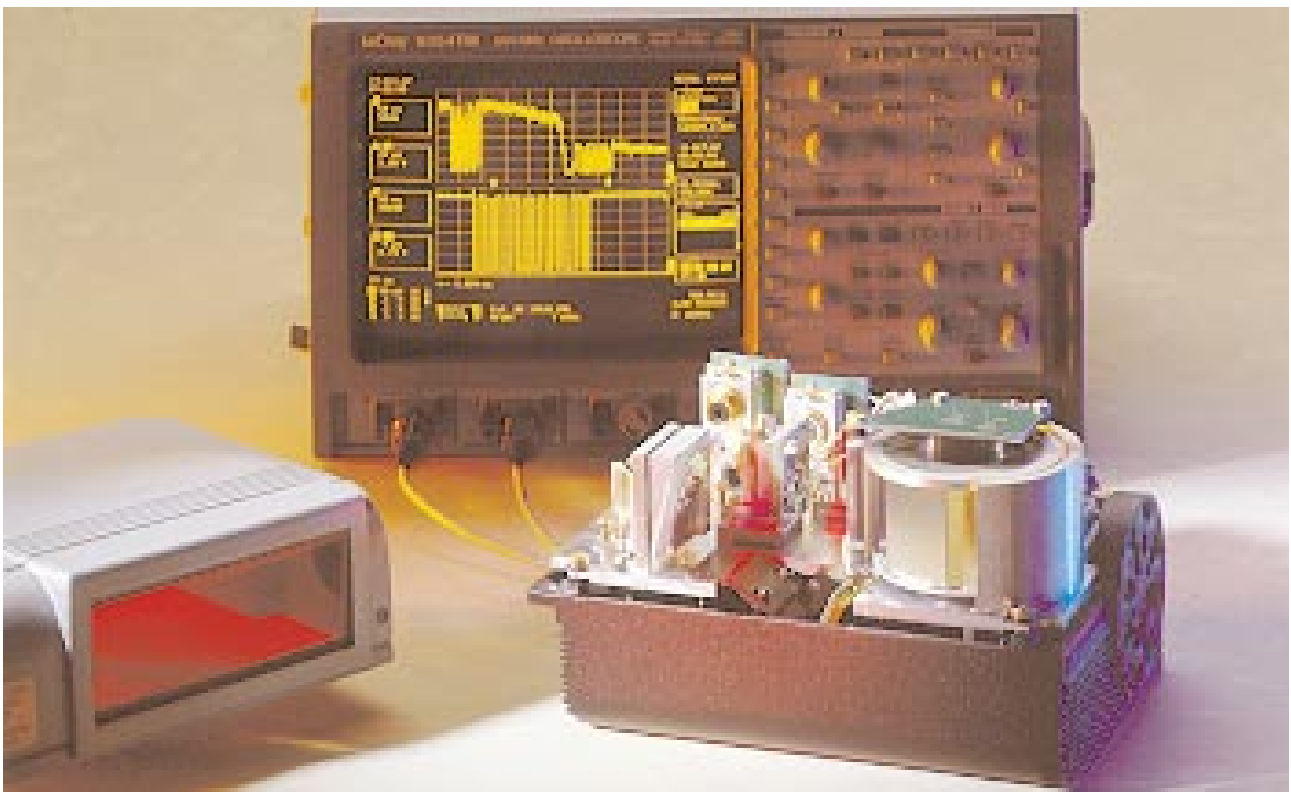

*ASTRA™: Outstanding reading performance using advanced fixed mounted optic architecture*

---

## Technologies



Advanced Code Reconstruction

**ACR™** technology (Advanced Code Reconstruction) performs bar code image reconstruction and decoding on small dimension labels placed anywhere on parcels.

The multiprocessor architecture based on a DSP TEXAS 320C32 microprocessor at 60 Mhz combines, in real time, partial slices of the code to be read, with a maximum decoding speed of 100,000 characters/sec. The ACR™ software algorithm offers maximum efficiency and decoding reliability. It performs multiple code reading and is not dependent on the label aspect ratio.

ACR™ technology also enhances the readability of poorly printed or damaged codes providing a great advantage in all reading conditions.

ACR™ is the basis for the implementation of powerful omni-directional reading stations.

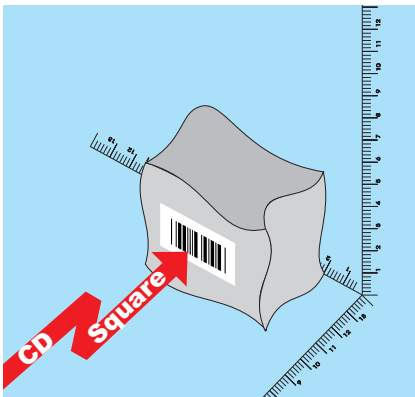

Code Distance Detector

**CDSQUARE™** (Code Distance Detector) is a revolutionary technology allowing accurate detection of bar code label positioning wherever the bar code is located, independent of the object shape.

The CDSQUARE™ system analyses the analog signal collected by the photodiode receiver, and identifies the area in which the code is located. It then measures the code distance from the scanner.

All these operations are done in real time for multiple bar codes and for every scan up to a maximum of 2000 scans.

The information provided by CDSQUARE™ is used to optimize decoding processing and perform object tracking, as well as offering the possibility to provide information about the object's shape or dimensions.

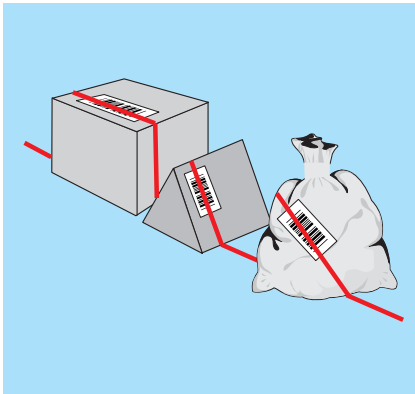

Integrated Parcel Tracking

**PackTrack™** is a DL patented system for parcel tracking supported by the DS8100 omnidirectional reading stations.

Thanks to a sophisticated controller, PackTrack™ tracks the parcels as they pass through the reading station, matching the codes to the correct box.

PackTrack™ can manage the most demanding applications, such as 6-sided reading systems, where traditional systems are unable to detect the real position of the code, necessary for tracking (for instance bar code labels on baggage in airport applications). Today, the limitations of these applications are overcome by CDSQUARE™ and PackTrack™ that assure 100% correct bar code assignment with 50 mm minimum gap between objects. PackTrack™ eliminates the need for external accessories required by the traditional tracking systems, such as photocells, encoders and height detector barriers, making installation and setting of the whole transport system less expensive, faster and easier.

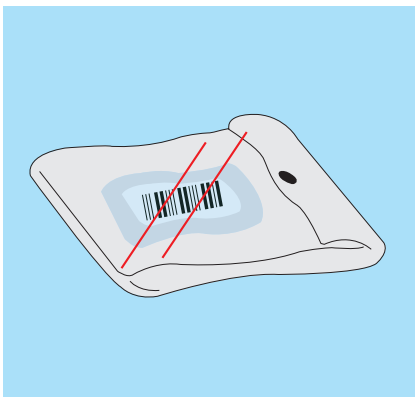

Twin Beam System

**TBS™** (Twin Beam System) is Datalogic's exclusive solution for reading codes covered by plastic film or wrapping material. The Datalogic patented TBS™ is made of an advanced optic architecture capable of changing the laser diode path and the beam's skew angle on the code to be read. Selecting the best reading angle, TBS™ makes the scanner insensitive to direct reflection and the bars' distortion caused by the plastic film.

DS8100 with the TBS™ system achieves close to a 100% read rate on codes covered by plastic film, completely overcoming one of the most demanding conditions for Auto-ID equipment in Material Handling applications.

# DS8100: Datalogic Technology at Work



## MULTIHEAD OMNI-STATION

- Building block solutions and multi-side reading stations
- Mechanical flexibility for optimum scan head positioning
- Standard metal frame for fast installation (as a single reader)

## ACR™

- Reconstruction of very low aspect ratio codes
- Reading of damaged or poor quality printed labels
- Multiple code reading
- Insensitive to mechanical vibration and start/stop movement

## ASTRA™

- Advanced multi-laser optic architecture
- Fixed mounted optic lens
- No mechanical focusing system
- 1000 mm (40 in) depth of field on 0.3 mm (12 mils) codes
- 1500 mm (60 in) depth of field on 0.5 mm (20 mils) codes

## HIGH SCAN RATE

- Up to 2000 scan/sec for each laser beam
- Transportation speed up to 5 m/sec (980 ft/min)
- High reading redundancy

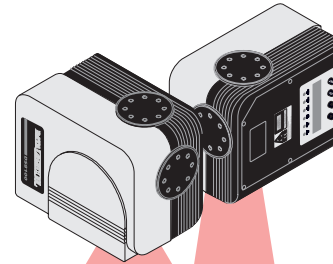

## CD<sup>5</sup>SQUARE™

- Real time label position measurement
- High measurement accuracy
- No external accessories
- Measurement of label position on irregularly shaped objects

## IDCUBE™

- 3-axes length measurement
- Volume estimation
- Integrated solution

## TBS™

- Reading of labels covered by plastic film or wrapping material
- Insensitive to direct reflection on plastic

ASTRA™

ACR™

CD<sup>5</sup>SQUARE™

TBS™

PackTrack™

## PackTrack™

- Increased system throughput
- 50 mm (2 in) gap between two parcels
- Parcel/label match in 6-side reading stations
- Parcel/label match of labels on irregularly shaped objects
- No external accessories



---

## Applications

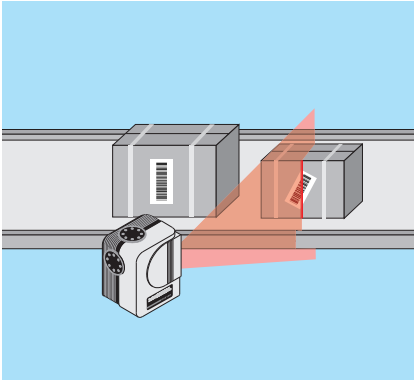

### **Single scanner reading station**

DS8100, in a stand alone configuration, is a powerful and flexible single beam scanner, which is easy to use and connect to your system. DS8100 is fitted with 3 serial interfaces for high speed communication, 6 Input/Output signals, and LCD display for local data visualisation.

DS8100 is used for applications on a conveyors or a palleting system, requiring top reading performance.

A built-in Advanced Code Reconstruction (ACR™) decoder allows reading of excessively tilted bar codes and assures the highest reading rates on damaged or poorly printed labels.

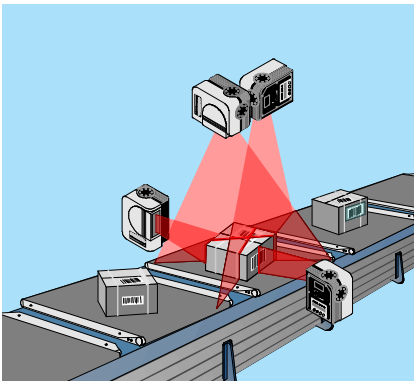

### **Omni-directional reading stations**

Thanks to Datalogic's exclusive technologies, DS8100 offers extraordinary features and performance that are particularly important for multi-side reading omni-stations.

The DS8100's reading performance reduces to a minimum the number of scan heads used in the scanning array, provides a 1 x 1 m (40 x 40 in) reading area, allows transportation speeds up to 5 m/sec. The standard 3-side and 5-side reading omni-stations are fitted with the Datalogic SC8000 system controller which performs real time data collection and provides general control of the station. DS8100 multi-side omni-stations are very easy to install, easy to use and maintenance free.

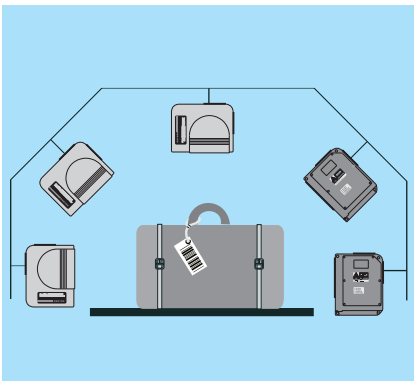

### **Automatic baggage handling and cargo applications**

Uniting the knowledge and the experience obtained from hundreds of installations, with the DS8100's advanced technologies and performance, Datalogic has defined innovative solutions for baggage handling and cargo applications. With more than a 1,500 mm (59 in) depth of field on IATA standard labels, DS8100 represents the new reference point for Automatic-ID in airports.

Thanks to fixed mounted optics and the elimination of any kind of mechanical focusing system, Datalogic solutions offer high performance, high reliability and low maintenance.

---

## WINHOST™

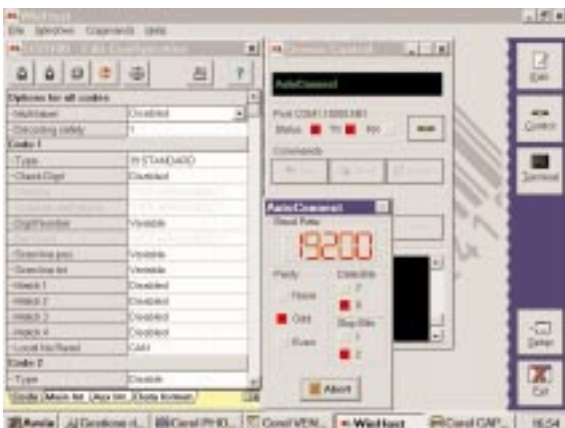

---

## VOYAGER™

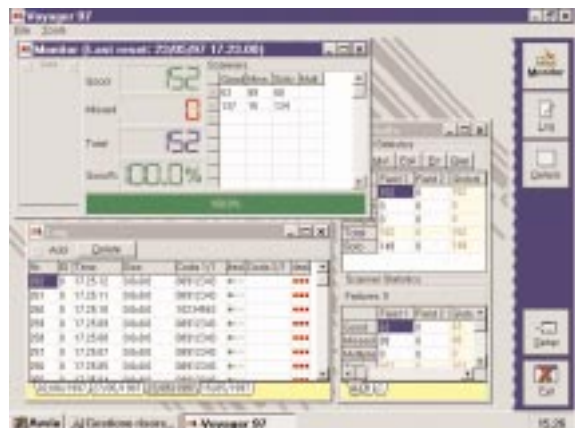

## Omni-Station System

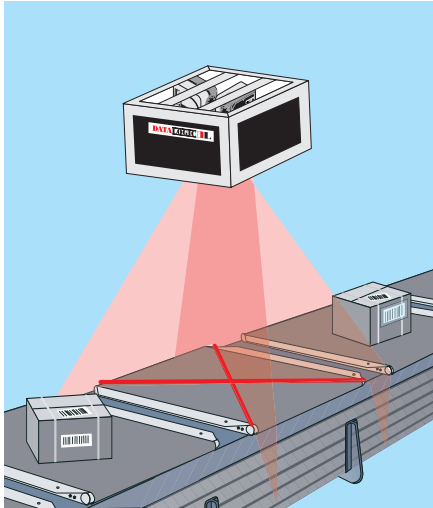

Installation, set-up and maintenance of omni-directional reading stations based on DS8100 are supported by a line of dedicated accessories designed to keep the station as easy to handle as an integrated omni-directional scanner, while maintaining all the flexibility of a multiple linear scanner system.

The DS8100 omni-station system is based on the **XMF-10** and **XMF-20** mounting frames, whose purpose is to allow easy installation of the omni-directional reading station on conveyors by four fixing points. The typical reading configurations based on the **XMF-10** are single-cross (two scanners positioned at 90 degrees) and 'delta' (three scanners positioned at 60 degrees). The **XMF-20** allows cross configurations to be doubled across the conveyor.

A line of brackets including standard L-shaped and fast release is available to simplify installation and maintenance operation. Datalogic also offers a line of dedicated power supply units and a complete set of prepared cables making it extremely simple to integrate the reading station on the conveyors.

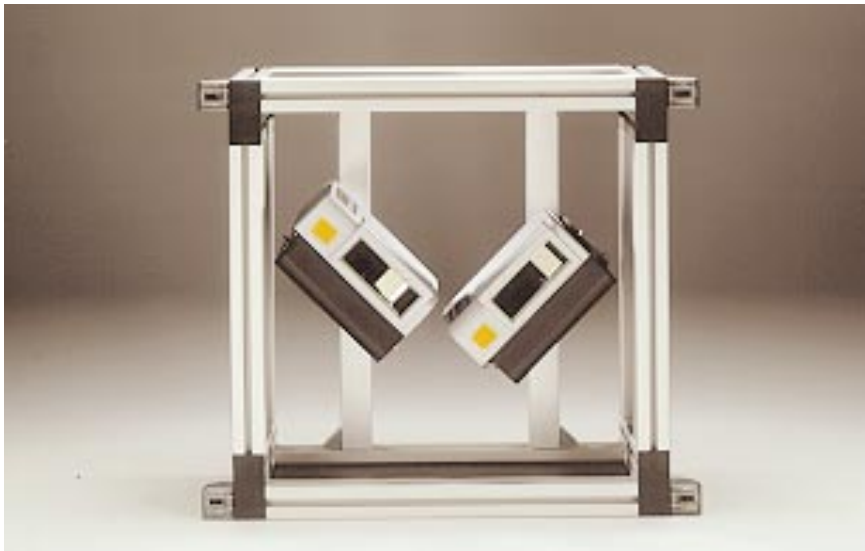

*DS8100 single cross omni-station on XMF-10 metal frame*



*DS8100 omni-station in top side reading controlled by SC8000*

### **Omni-station benefits**

- Top reading performance on the market
- Easy installation by standard metal frames
- Single and multi-side reading omni-stations
- High performance reading on the fastest conveyors
- High system throughput with a 50 mm (2 in) gap between two parcels
- Reading of labels under plastic film
- Complete immunity to ambient light
- System reliability and maintenance free
- User friendly interface
- Automatic set up based on **WINHOST™** software package
- Real time reading statistics based on **VOYAGER™** software package

# Models and Accessories

MODEL	OPTICAL ARCHITECTURE		INTERFACES		OSCILLATING MIRROR	ORDER NO.
	2 Laser	4 Laser	Bus	Serial		
DS8100-2000	•		•			932401000
DS8100-2010	•		•		•	932401790
DS8100-2100	•			•		932401010
DS8100-2110	•			•	•	932401800
DS8100-4000		•	•			932401020
DS8100-4010		•	•		•	932401810
DS8100-4100		•		•		932401030
DS8100-4110		•		•	•	932401820
<b>ACCESSORIES</b>						
GFC-80 90 Degrees mirror DS8100						93A251020
XMF-10 Single cross metal frame DS8100						93ACC1060
XMF-20 Double cross metal frame DS8100						93ACC1050
FBK-8100 Fast bracket kit (2 pcs) DS8100						93ACC1130
US-8100 Bracket kit (10 pcs) DS8100						93ACC1140

\*Refer to local subsidiaries/distributors for Power Units, Cables, Connectors, and Terminators

## Specifications

POWER SUPPLY	20 to 30 Vdc
POWER CONSUMPTION	35 W*
LIGHT SOURCE	Visible Laser Diode (650 nm)
LIGHT RECEIVER	Avalanche photodiode
MAX. RESOLUTION CODE	0.20 mm (8 mils)
SCAN RATE	1,000 (2,000) scans per second
MAX. DEPTH OF FIELD	1,000 mm (40 in) on 0.30 mm (12 mils) codes 1,500 mm (60 in) on 0.50 mm (20 mils) codes
MAX. READING DISTANCE	1,500 mm (60 in) on 0.30 mm (12 mils) codes 2,000 mm (80 in) on 0.50 mm (20 mils) codes
READABLE CODES	22 symbologies incl. 2/5 family, Code 39, Code 93, Code 128, EAN/UPC, Codabar
CODE AUTODISCRIMINATION	Up to 10 different codes
SERIAL INTERFACE CARD	Main interface RS232/RS485/20 mA C.L. Baud rate 1,200 to 57,600 bauds Aux. interface RS232/RS485
BUS INTERFACE CARD	Main interface LONWORK Baud rate 1.250 Mb/sec Aux. interface RS232
INPUT SIGNALS	2x 'Presence sensor' and 1 auxiliary (NPN/PNP transistor)
OUTPUT SIGNALS	'No read', 'Right code' and 1 auxiliary (NPN transistor open collector and emitter)
SET UP	Built in keypad and menu driven display / Via serial port and Windows™ based software program
OPERATING MODES	'On line', 'Serial on line', 'Automatic', 'PackTrack', 'Test'
DISPLAY	2 line by 20 character LCD
KEYPAD	4 keys
LED INDICATORS	4 LED status indicators
LASER CLASSIFICATION	IEC 825 Class 2
LASER CONTROL	Security system to turn laser Off in case of motor slow down or failure
DIMENSIONS	215.5 x 170.5 x 126.5 mm (8.48 x 6.71 x 4.98 in)*
WEIGHT	5.0 Kg (11 lbs) approx.*
CASE MATERIAL	Aluminium
OPERATING TEMPERATURE	0 to 45 °C (32 to 113 °F)
STORAGE TEMPERATURE	-20 to 70 °C (-4 to 158 °F)
HUMIDITY	90% non condensing
VIBRATION RESISTANCE	IEC 68-2-6 test FC 1.5 mm, 10 to 55 Hz; 2 hours on each axis
SHOCK RESISTANCE	IEC 68-2-27 test EA 30 G 11 ms; 3 shocks on each axis
PROTECTION CLASS	IP64 (IP65 optional)

\*Please refer to the user manual for information on oscillating mirror models

## Dimensions

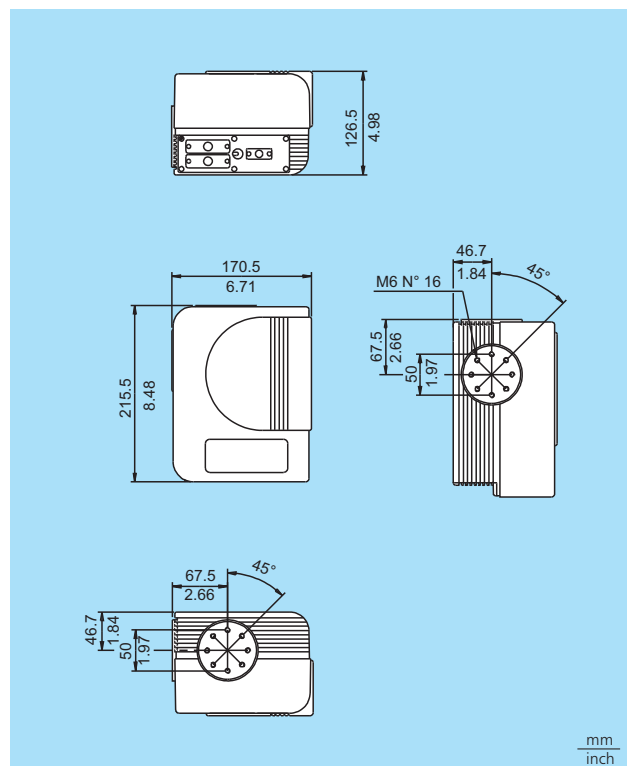

# DATA LOGIC DL

Bar Code & More

Product and company names and logos referenced may be either trademarks or registered trademarks of their respective companies.

**tralia**  
Datalogic PTY LTD.  
Tel. +61 3/95589299  
Fax +61 3/95589233  
sales@datalogic.com.au

**tria**  
Datalogic Handelsges MBH  
Tel. +43 2236/258820  
Fax +43 2236/258825  
office@datalogic.co.at

**Den ark**  
Datalogic AB  
Tel. +45 44/209970  
Fax +45 44/209972  
info@datalogic.se

**rance**  
Datalogic France S.A.  
Tel. +33 1/60921111  
Fax +33 1/60921340  
dlfrance@worldnet.fr

**er any**  
Datalogic GmbH  
Tel. +49 7026/6080  
Fax +49 7026/5746  
info@datalogic.de

**taly**  
Datalogic S.p.A.  
Tel. +39 051/6459300  
Fax +39 051/726562  
vendititalia@datalogic.it

**a an**  
Izumi Datalogic Co., Ltd.  
Tel. +81 78/2723400  
Fax +81 78/2722003  
idlmarke@izumi-datalogic.co.jp

**etherlan**  
Datalogic Optic Electronics BV  
Tel. +31 346/572888  
Fax +31 346/568736  
info@datalogic.nl

**S ain**  
Datalogic France S.A.  
Tel. +34 93/3221227  
Fax +34 93/4394136  
datalogic@sei.es

**S een**  
Datalogic AB  
Tel. +46 40/385000  
Fax +46 40/385001  
info@datalogic.se

**nite ing o**  
Datalogic UK Ltd.  
Tel. +44 1582/464900  
Fax +44 1582/464999  
enquiries@datalogic.demon.co.uk

**S**  
Datalogic Inc.  
Tel. +1 606/6897000  
Fax +1 606/3344970  
info@datalogic.com



We reserve the right to make modifications and improvements

Datalogic ality artner



These products are available through the worldwide network of atalogic uality Partners.