

# WinSystems®

## PC/104 MODULE

## PCM-SC520-G AMD SC520 SBC with 10/100 Ethernet

### FEATURES

- 133MHz AMD SC520 CPU
- Supports Windows® CE, Linux, and other x86-compatible operating systems (including DOS)
- PC/104-compliant form factor
- Up to 256Mbytes of SDRAM using SODIMM
- Optional 32Mbytes of soldered down SDRAM
- Socket for up to 1GB bootable DiskOnChip®, 512KB SRAM, or 1MB EPROM
- Bootable Type I and II CompactFlash (CF) supported
- Industry standard Phoenix BIOS
- Intel 82551ER 10/100 Ethernet controller
- Four RS-232 serial ports with FIFO, COM1 and COM2 with RS-422/485 support
- Bi-directional LPT port supports EPP/ECP
- Onboard EIDE hard disk interface
- Floppy disk controller supports one or two drives
- x86-compatible interrupt and DMA controllers
- Three 16-bit counter/timers
- AT keyboard controller and PS/2 mouse port
- 16-bit PC/104 expansion connector
- Watchdog timer and power fail reset
- Up to two minute reset on watchdog timer
- Real-time clock with battery backup
- Status, hard disk and Ethernet activity LEDs
- Speaker header for remote PC speaker
- Small size: 3.6 x 3.8 inches (90 mm x 96 mm)
- Replaces WinSystems' PCM-SX and PCM-586

The PCM-SC520-G is an x86-compatible PC/104-compatible, single board computer with onboard Ethernet support for network-enabled applications. Because of its small size and low power consumption, it is well suited for portable and mobile products.

It is powered by an AMD SC520 operating at 133MHz. A 10/100 Ethernet controller provides high-speed Ethernet access in addition to four serial COM ports. Up to 256MB of memory can be installed in a SODIMM socket. Also, a CompactFlash can be installed for on board solid state flash storage.

### FUNCTIONAL CAPABILITY

**Processor** - This board is based upon an AMD 133MHz SC520. The SC520 CPU is an integrated 32-bit microcontroller with PC/AT-compatible peripherals, PCI-host bridge and synchronous DRAM controller.

The CPU portion is the AMD 5x86 CPU with floating point unit (ANSI/IEEE 754 standard), and 16-Kbyte write-back

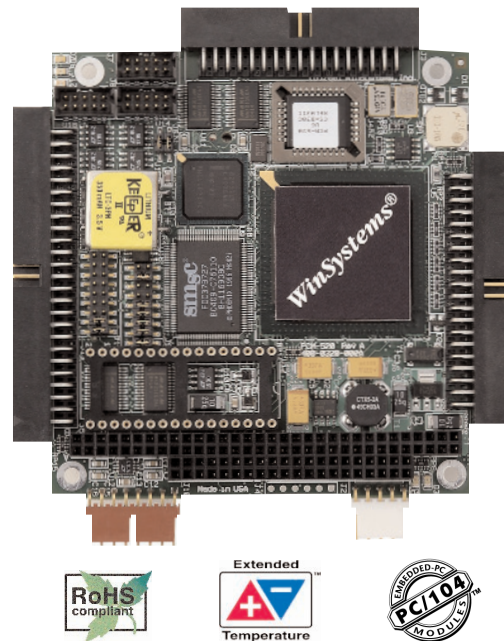

- Only +5 volts required
- Low power, no fan required
- RoHS-Compliant, meets EU directive 2002/95/EC
- -40°C to +85°C temperature range

cache. It also integrates standard PC/AT-compatible peripherals and core logic including two serial COM channels, programmable interval timer, real-time clock, DMA controller, and interrupt controllers. It is based upon 0.25-micron process technology that allows for its low power consumption in a small BGA package.

The AMD SC520 runs the industry-standard x86 micro-processor instruction set. Its software compatibility supports the use of Windows® CE, Linux and DOS operating systems, x86-compatible real-time executives, development tools, and applications programs. This improves time-to-market and allows easy software migration to the board.

**Memory** - The board supports 32-, 64-, 128-, or 256-Mbytes of Synchronous Dynamic RAM (SDRAM) that is installed on the board by using a 144-pin SODIMM. A PC-66 or PC-100 compatible part (non-registered, unbuffered) with gold-plated fingers is the recommended SDRAM. Extended temperature memory is available directly from WinSystems.

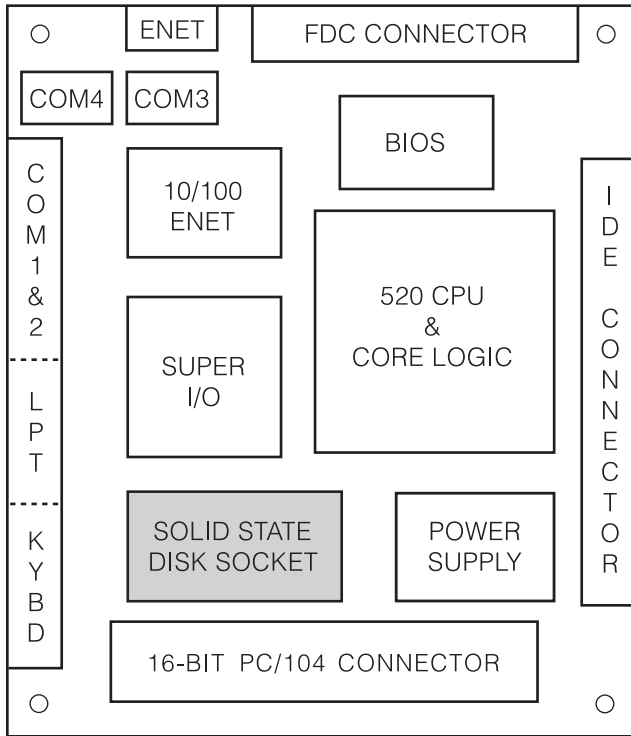

**PCM-SC520-G BLOCK DIAGRAM**

is a factory option, the board can be built with 32MB DRAM soldered directly to the pcb. This is for applications that are subject to severe shock and vibration. Please contact a WinSystems' application engineer for technical details and ordering information.

The board is shipped from the factory with no memory installed. That permits the user to either install or upgrade the memory capacity in the field.

**BIOS** - An industry-standard, Phoenix BIOS provides configuration flexibility, performance and AT-compatibility. It is loaded with a factory default that can be changed by the user. The BIOS is located in an EEPROM that can be modified without removing the storage device from the board. It will support diskless, keyboardless, and videoless operation as well as BIOS shadowing.

**Solid State Disk (SSD) Support** - A designer can substitute onboard semiconductor devices for applications where the environment is too harsh for mechanical hard disks or floppy drives while offering significant speed advantages. The PCM-SC520-G can support CompactFlash, DiskOnChip®, SRAM, and EPROM devices. Only the CompactFlash and DOC are bootable devices

A JEDEC standard 32-pin, machine-tooled socket is provided to accept an M-Systems' DiskOnChip (DOC). The DOC offers from 16MB to 1Gbyte storage capacities in a single device. It includes an internal flash file

system that provides hard disk read/write compatibility, automatic bad block management, and wear-leveling. DOCs are available in commercial and industrial temperature ranges.

A CompactFlash connector will accept Type I and II CompactFlash cards. It is wired to the primary IDE channel. A designer can use bootable CompactFlash cards as data storage for applications where the environment is too harsh for rotational hard disks or floppy disk drives.

WinSystems offers industrial-grade CompactFlash cards that can be used to boot and store data like a solid state disk drive while operating from -40° to +85°C for high capacity, harsh embedded applications. The sustained data transfer rate is very fast, plus an on-card wear leveling algorithm extends the number of write cycles to the part. These RoHS-compliant cards will fit into any computer, SBC, or instrument with a CompactFlash socket. For more information, go to [www.industrialcompactflash.com](http://www.industrialcompactflash.com)

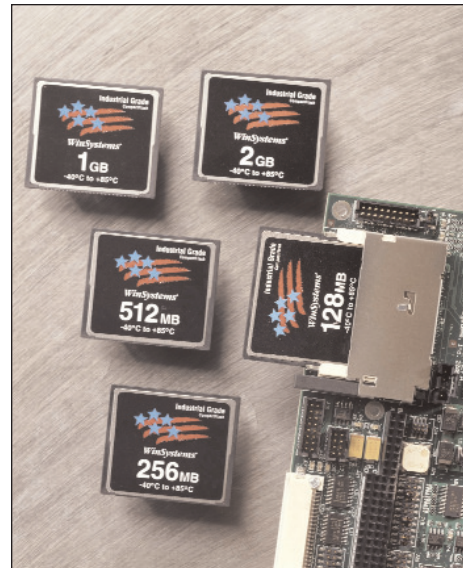

**WinSystems' Industrial CompactFlash**

**Rotational Disk Support** - Up to two, 3.5" or 5.25" floppy disk drives are supported. Also an industry-standard 16-bit IDE interface is provided to support up to two hard disks. A status LED provides visual status during IDE data transfers.

**Direct Memory Access (DMA)** - DMA is supported. Channel 2 dedicated to the floppy disk controller. The LPT is plug-and-play configurable. The other DMA channels are wired to the PC/104 connector.

**Interrupts** - Two 82C59A-compatible interrupt controllers accept inputs from the onboard peripherals and the PC/104 bus connectors.

---

**Ethernet Controller** - An Intel 82551ER is the 32-bit PCI Ethernet controller chip used for high-speed data transfer. It has auto-negotiation capability for speed, duplex, and flow control. It supports IEEE 802.3 10-BaseT and 100BaseT in either full- or half-duplex mode at both 10 and 100 Mbps. In full-duplex mode, it adheres to the IEEE 802.x Flow Control Specification.

Two large 3Kbyte transmit and receive FIFOs help prevent data underruns and overruns. It has fast back-to-back transmission support with minimum interframe spacing. It also has improved dynamic transmit chaining with multiple priorities transmit queues. There are three light emitting diodes (LEDs) are on the PCM-SC520-G to provide a visual indication of the link status, network activity and network speed. The yellow Link Integrity LED is lit when there is a valid connection detected. The green Activity LED blinks on and off when activity is detected on the wire. The red LED is on if a 100BASE-T link is detected and off if a 10BASE-T link is detected.

The 82551ER chip is very popular both in the commercial and industrial PC-compatible market. This means that most PC-compatible drivers, utilities and 10/100 Ethernet supported operating systems will work directly with the PCM-SC520-G. The configuration information describing the device's architecture, address, interrupt, etc. is stored in a serial EEPROM.

A 10-pin connector is on the board for the Ethernet. WinSystems offers an optional adapter cable, called the CBL-267-2. It is a 1.5"-long adapter cable from a 2 mm socket connector to RJ-45 field terminal jack.

Independent control of transmit, receive, line status and data set interrupts are on all channels. Each channel is setup to provide internal diagnostics such as loopback and echo mode on the data stream. An independent on-chip software programmable baud rate generator is selectable from 50 through 115.2 kbits/sec. Individual modem handshake control signals are supported for all channels.

RS-232 interface levels are supported on all four channels. The RS-232 drivers have an on-chip charge pump to generate the plus and minus voltages so that the PCM-SC520-G only requires +5 volts to operate.

COM1 and COM2 are wired to a 50-pin connector at the edge of the board. WinSystems offers the optional cable, CBL-247-1, to adapt each serial channel to 9-pin male "D" connectors. COM3 and COM4 also have jumper selectable RS-422/485 support. The RS-422/485 provides separate

balanced transmit and receive signal pairs. For RS-485 multi-drop lines, one signal pair can be used for "party line" network structures. COM3 and COM4 are each wired to a 10-pin, 2 mm connector on the board. WinSystems' optional cable, CBL-123-5, adapts each the COM3 and COM4 serial channels to 9-pin male "D" connectors.

**Line Printer Port** - This is a multi-mode parallel printer port that supports the PS/2 standard bi-directional parallel port (SPP), Enhanced Parallel Port (EPP), or Extended Capabilities Port (ECP). The output drivers support 14 mA per line.

The printer port can also be used as two additional general-purpose I/O ports if a printer is not required. The first port is configured as eight input or output only lines. The other port is configured as five input and three output lines. WinSystems offers the standard cable, CBL-247-1, to adapt the parallel LPT port to a 25-pin female connector.

**Keyboard and Mouse Controller** - An integrated 80C42 equivalent keyboard controller supports a PC/AT-type keyboard. Additionally, a PS/2-compatible mouse is supported on the PCM-SC520-G.

**Timers** - Three, independent 82C54 compatible 16-bit timers are supported.

**Real-Time Clock/Calendar** - A real-time clock is used as the AT-compatible clock/calendar. It supports a number of features including periodic and alarm interrupt capabilities. In addition to the time and date keeping functions, the system configuration is kept in CMOS RAM contained within the clock section.

**Watchdog Timer** - An onboard retriggerable watchdog timer provides the timeout intervals which can be set for either 1.5 seconds or over 200 seconds. This interval can be dynamically changed or disabled under program control. The timer must be updated at least once every interval otherwise a failure is assumed and the board will be reset. This circuit is important for use in remote and unattended applications

**Reset** - A precision voltage comparator monitors the +5 volt status. Upon detection of an out-of-tolerance condition, the board is reset. This action is critically important in order to detect brown-out or power fail conditions. The reset circuit also ensures that the power is nominal before executing a power-on reset. This circuit also inhibits the processor's memory write line, preventing invalid data from being written to non-volatile memory during power fluctuations.

---

**Battery Back-up** - A 350-mAH battery supplies the PCM-SC520-G board with standby power for the real-time clock and CMOS set-up RAM. However, an onboard EEPROM will save the CMOS setup data in case battery power is unavailable.

A power supervisory circuit contains the voltage sensing circuit and an internal power switch to route the battery or stand-by voltage to the circuits selected for backup. The battery automatically switches ON when the Vcc of the systems drops below the battery voltage and back OFF again when Vcc returns to normal.

**Speaker** - An onboard speaker provides sound generation. A beep code is generated that corresponds to any BIOS error codes (if required) during the power up or reset sequence.

**Power** - Power is brought into the board through an 8-pin connector at the edge of the board or through the PC/104 connector. The  $\pm 12$  volts are wired directly to the PC/104 connector and not used by the PCM-SC520-G.

**PC/104 Expansion** - The PCM-SC520-G has a 16-bit PC/104 interface and connector. PC/104 modules are self-stacking and plug together in a "piggy back" configuration to serve as a mezzanine expansion bus.

## SOFTWARE SUPPORT

The PCM-SC520-G is designed to be PC-AT software compatible. This means that it will work with a host of operating systems software, executives, development tools and utilities to quickly create software for embedded systems. It works with ROM-DOS, MS-DOS, Linux, Windows® CE as well as other popular real-time operating systems such as QNX, and VxWorks that require a "PC/AT" hardware environment.

**Software Developers Kits** - WinSystems offers software developers kits to supply the necessary hardware, software and cables to begin program development with the PCM-SC520-G board. It consists of all necessary cables, semiconductor memory, hard disk drive, DVD drive, 1.44MB high density 3.5 inch floppy disk, and triple output power supply housed in a black anodized enclosure. The power supply is an 80-Watt universal switcher with output voltages of +5 volts at 12A, +12 volts at 3A, and -12 volts at 1A. There are Windows CE, Linux, and ROM-DOS developer kits available for the PCM-SC520-G.

WinSystems also offers several different Flash-based developers kits for those applications that do not need rotational media during development. When you order a PCM-SC520-G along with the kit of your choice, WinSystems will jumper the CPU, program and install the Flash part to the PCM-SC520-G. It includes a power supply, PCM-POST, Flash memory, operating system, cables and utility software. For more information please contact your factory applications engineer.

## SPECIFICATIONS

### Electrical

PCM-SC520-G CPU Clock: 133MHz

PC/104 Interface: 16-bit

Serial Interface: Four serial COM channels

Ethernet: 10/100 Mbps Fast Ethernet

LPT Interface: Bidirectional Centronics

IDE Interface: 16-bit, supports two drives

Floppy Disk Interface: Supports either one or two  
360K/720K/1.2M/1.44M

Vcc = +5V +5% @ 900mA typ. with 32MB DRAM

### System Memory

Addressing: 256 Megabytes

Capacity: 32, 64, 128, or 256MB of SODIMM  
SDRAM or 32MB soldered down SDRAM

### Solid State Disk

Capacity: One 32-pin socket supports up to 1GB  
One Type I and II CompactFlash socket

### Mechanical

Dimensions: 3.6" x 3.8" (90 mm x 96 mm)

### Connectors

Serial, Parallel,

Mouse and Keyboard: 50-pin, 0.100"

Floppy: 34-pin, 0.100"

IDE: 40-pin, 0.100"

PC/104 Bus: 64-pin, 0.100"

40-pin, 0.100"

COM3: 10-pin, 2 mm header

COM4: 10-pin, 2 mm header

Ethernet: 10-pin, 2 mm header

Power: 8-pin, in-line Molex

### Environmental

Operating Temperature: -40°C to +85°C

Non-condensing relative humidity: 5% to 95%



---

---

## ORDERING INFORMATION

PCM-SC520-G-0M	PC/104 133MHz SBC with 10/100 Ethernet controller, non-stackthrough module
PCM-SC520-G-0M-ST	PC/104 133MHz SBC with 10/100 Ethernet controller, and stackthrough connector
PCM-SC520-G-32M-C	PC/104 133MHz SBC with 10/100 Ethernet controller and 32Mbytes of soldered down SDRAM, non-stackthrough module
PCM-SC520-G-32M-C-ST	PC/104 133MHz SBC with 10/100 Ethernet controller, 32Mbytes of soldered down SDRAM, and stackthrough connector

### **-40°C to +85°C Industrial CompactFlash Memory**

CFLASH-G-128M-I: 128MB CFlash - RoHS

CFLASH-G-256M-I: 256MB CFlash - RoHS

CFLASH-G-512M-I: 512MB CFlash - RoHS

CFLASH-G-1024-I: 1GB CFlash - RoHS

CFLASH-G-2048-I: 2GB CFlash - RoHS

CFLASH-G-4096-I: 4GB CFlash - RoHS

CFLASH-G-8192-I: 8GB CFlash - RoHS

Larger CompactFlash capacities and faster Write speeds to be released soon.

FLASH-MD2200-Dxx DiskOnChip; xx = 16MB to 1GB capacities

## Cables

CBL-123-5	COM 3 and 4 serial DTE cable
CBL-174-1	18", 8-wire power cable
CBL-225-1	PS/2 mouse adapter
CBL-247-1	Multi-I/O cable for keyboard, LPT, COM1, and COM2
CBL-267-2	1.5-foot cable with Ethernet jack (female)
CBL-267-3	6-foot cable with Ethernet plug (male)

WinSystems reserves the right to make changes to products and/or documentation without further notification.

Product names of other companies may be trademarks of their respective companies

