

Main Features

- Supports Intel® Core™ 2 Duo, Core™ Duo & Core™ Solo Processor Family
- Intel® 945GME Chipsets
- 2 x 240-pin DDR2 DIMM Sockets Support Un-buffered Non-ECC DDR2 400/533/667 up to 4GB
- 2 x Intel® 82573L PCI Express Gigabit LAN
- Supports LVDS/VGA Display and 1 PCIe x16 Slot
- CompactFlash Socket

Product Overview

The EBC 500 is a 5.25" form factor embedded board computer utilizing the latest Intel® Core™ 2 Duo processor with Intel's 65-nanometer technology and new micro-architecture. EBC 500 supports Intel® Core™ 2 Duo, Core™ Duo, Core™ Solo, and Celeron® M family processors up to 2.17 GHz with 533/667 MHz FSB and up to 4MB L2 cache.

The incorporated mobile Intel® 945GME and ICH7-M DH chipset supports two 240-pin DDR2 DIMM socket up to 4GB un-buffered non-ECC DDR2 533/667 MHz, one PCI express x16 slot for superb graphic display and two PCI express x1 Gigabit Ethernet LAN for fastest network connection. The EBC 500 also supports two SATA, IDE, CF, six USB 2.0, VGA & LVDS, four COM, and Parallel port.

The RoHS compliant EBC 500 embedded board computer consumes very low power and is designed to deliver higher processing power with greater performance-per-watt to fit in various environments for embedded applications. The new Intel® Core™ 2 Duo processor in the EBC 500 has a flexible design that is able to create new solutions for various environments.

Specifications

CPU Support

- Intel® Socket M
- Supports Intel® Core™ 2 Duo, Core™ Duo, Core™ Solo family processors with 533/667 MHz
- Intel® Embedded Processor List (Intel® Longevity CPU):
Core™ 2 Duo Processor (T7400 2.16GHz)
Core™ Duo Processor (T2500 2.0GHz)
Core™ Solo Processor (Celeron® M 440 1.86GHz)

Main Memory

- 2 x 240-pin DDR2 DIMM socket, up to 4GB un-buffered non-ECC DDR2 533/667 SDRAM
- Note: Maximum 4GB. Actual memory size is dynamic based on the OS I/O resource allocation.*

Chipset

- Intel® 945GME Graphics Memory Controller Hub (GMCH)
- Intel® 82801 GHM ICH7 Mobile Digital Home (ICH7-M DH)

BIOS

- Award system BIOS
- Supports Soft off, Wake on LAN, Power On by PS2 Keyboard Function Key, RTC alarm Power On
- Power on after power failure

- Plug & Play support
- 4M bits flash ROM

On-board LAN

- 2 x Intel® 82573L PCI Express Gigabit Ethernet
- Supports Boot From LAN (PXE)
- Supports Wake on LAN (When 5Vsb power available). (LAN1 only)
- 2 x RJ45 with LED

Display

- Intel® 945GME chipset with integrated graphics controller, Max. 128MB by Intel® Dynamic Video Memory Technology (DVMT) 3.0
- Analog VGA interface:
1 x DB15 VGA port
Resolution up to 1400X1050 (Tested); Chipset supports up to 2048 x 1536
- LVDS interface:
2 x DF-13 20-pin LVDS connector for internal connection, supports single (18bit) or dual pixel (36bit) LVDS panel
- CCFL interface:
1 x CCFL for LCD Panel Backlight Inverter

Audio

- Realtek ALC655 CODEC for AC97 v2.1 CODECI
- Interface: Mic in and Speaker out connector, Line in with pin header

Block Diagram

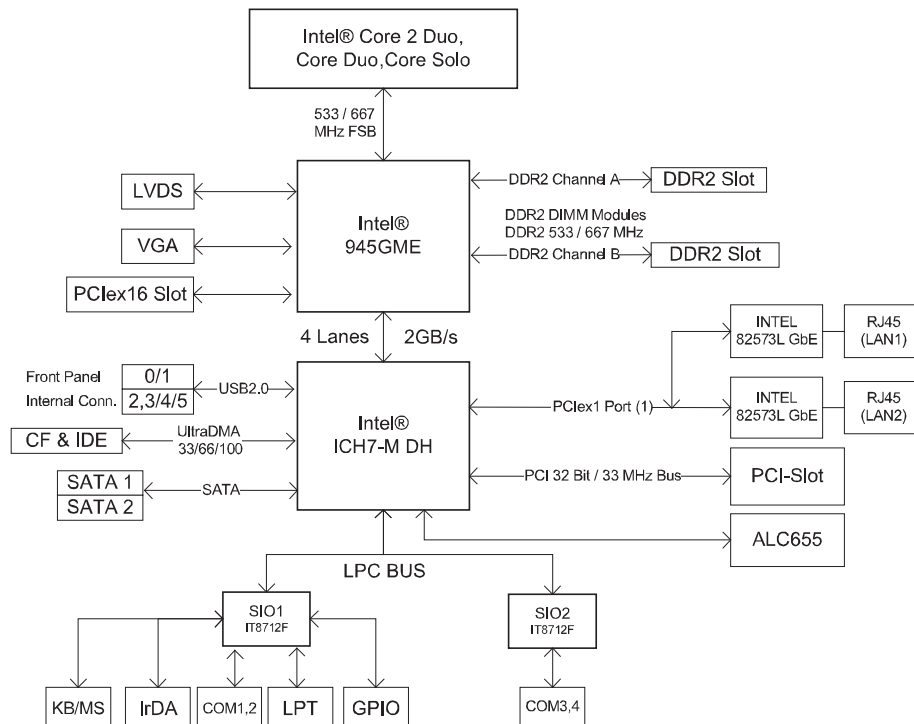

Expansion

- 1 x PCIe x16 slot
- 1 x PCI slot

I/O Interface

- USB 2.0: 2 ports edge connector
- USB 2.0: 4 ports, by 1x6 2.5mm JST connector
- Serial ports: 4 x SIO, with 2x20 box header (2.0mm) support RS-232 only
1 x jumper to switch 5V and 12V power source
- Parallel port: 1 port, with 2x13 box header (2.0mm)
- PS/2: 1 x Mini-Din Keyboard/Mouse
- GPIO: Support 4 sets of general purpose I/O each with TTL level (5V) interface
- FAN: Two 1 x 3-pin connectors for system Fan, one 1 x 4 pin connector for CPU Fan
- 1 x on-board 5-pin header for IrDA, TX, RX
- On-board buzzer/SMBus 2.0/Reset/On off switch button

Watchdog Timer

- Watchdog Timer is programmable by software from 1 to 255 seconds
(Tolerance 10% under room temperature 25°C)

Storage

- 2 x SATA II ports
- 1 x IDE 44-pin connector
- 1 x CF internal socket, supports One Type I & II Compact Flash Card (Primary Master)

System Monitor

- 5 voltage (For +3.3V, +5V, +12V, Vcore and +2.5V)
- 3 Temperatures (CPU, two external Temperature Sensor)
- 3 FANs speed (CPU and System FANs)

On-board RTC

- On-chip RTC with battery back up
- 1 x External Li-ion Battery
- RTC Tolerance less than 2sec (24 hours) under 25°C environment

Power Requirements

- Supports both AT and ATX Mode (default setting is AT mode)

CPU: P-M 2.17GHz	+12 V	+5 V
Memory: 2 x 1G DDR2		
Full-Loading Mode	3.25 A	4.97 A
Light-Loading Mode	0.40 A	2.97 A

NOTE:

1. Full Loading: Utilize CPU 100% with Burn-in test running
2. Light Loading: Utilize CPU loading below 5% without data or application running.

Dimensions

- 5.25" form factor: 203mm (L) x 146mm (W) (7.9" x 5.7")

Environment

- Board level operating temperature: 0°C to 60°C
- Storage temperature: -20°C to 80°C
- Relative humidity: 10% to 90% (Non-condensing)

Certifications

- CE approval
- FCC Class A

Ordering Information

- **EBC 500 (P/N: 10E00050000X0)** RoHS Compliant
5.25" Embedded Board supporting Intel® Core™ 2 Duo, Core™ Duo and Core™ Solo CPU w/ VGA/LVDS/Audio/4 COMs/6 USB2.0/Dual Gigabit LAN
- **Packing List**

Part No.	Description
60233USB59X00	USB CABLE
60233POW73X00	POWER CABLE (2x10 TO 2x5)
60233POW34X00	POWER CABLE (BIG 4P)
60233MK202X00	PS2 Y CABLE
60233IDE86X00	IDE CABLE 44P TO 40P
60233ATA06X00	SATA CABLE L: 330mm
6023325262X00	PRINT CABLE
6023309402X00	COM CABLE L: 300mm