



High Accuracy Analog and Digital I/O for PC/104 non-DMA Systems MPC565



The MPC565 enables high accuracy analog and digital I/O for the growing number of non-DMA processors in the embedded Intel family. It provides a 1024 word deep FIFO to store readings from up to 32 single-ended 16-bit analog inputs that are fault protected to $\pm 40V$. The analog input section offers individual channel selection of single-ended or differential modes in any combination. The MPC565 also features basic and autoscan modes. Basic mode directly controls all modes, gains, channel selection, and filters. With autoscan mode, a user can preset individual channel attributes—channel on/off, mode, gain, and low pass filter in on-board RAM.

In autoscan mode, a pacer clock automatically moves samples to an on-board FIFO register.

Features

- ✓ 32 channels of 16-bit analog input
- ✓ Fault protection on analog/digital
- ✓ Ultra-low noise design
- ✓ DSP and noise analysis software
- ✓ Low-pass filtering
- ✓ 14-bit, 4-channel DAC
- ✓ Digital I/O, Counter/Timer
- ✓ 5V only operation from PC/104
- ✓ -40° to $+85^{\circ}C$ operation available

FIFO flags can trigger a system IRQ to allow efficient simultaneous read/write servicing by the program. The analog input includes a low-drift reference, noise-protected by a faraday shield. Optional 14-bit analog outputs have full-scale output of $\pm 10.1V$. The digital-to-analog converter is noise-protected by a faraday shield. Each output has a 1-pole lowpass filter.

Twelve digital I/O lines can be individually set for input or output, with fault protection against power sequencing and static discharge.

All analog power supplies are generated from the 5V input. The on-board analog supplies include input and output filtering and post-regulation of the initial converters providing low-noise and stable power.

Software Support

Example code for all functions
C-code/Mathcad™ for advanced
algorithms

Compatible Hardware

Any Micro/sys CPU with PC/104
expansion connector

Mounting/Packaging

PC/104 standard

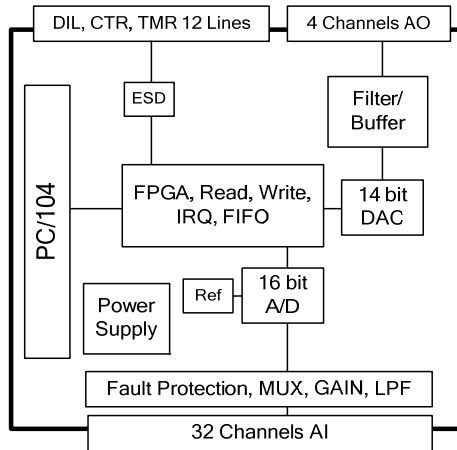

Specifications:

Mechanical:

- ❑ PC/104 standard
- ❑ 3.55" (plus I/O region) x 3.775"

Power Requirements:

- ❑ +5V \pm 5% at 500mA

Environmental:

- ❑ 0° - +70°C operating
- ❑ -40° - +85°C operating, -ET version
- ❑ 5%-95% relative humidity, non-condensing

PC/104 Interface:

- ❑ 16-bit transfers
- ❑ IRQ 3, 4, 5, 6, 7, 9, 10, 11, 12, 14, 15 supported

Digital I/O:

- ❑ 12 Multi-function TTL-level bit selectable I/O at 8mA sink/source
- ❑ Ext-trigger, Ext-pacer clock, User I/O
- ❑ Any/all inputs can generate an IRQ
- ❑ Read-back function on outputs

Analog Inputs:

- ❑ 16-bit, 32-channels individually selected for single/differential
- ❑ ADC conversion time of 5usec
- ❑ -3dB typical full-power response of input circuitry: 20Vpp @ 35kHz, 5Vpp @ 100kHz
- ❑ Each channel can be set by software for the following attributes: on/off, single/differential, input range of \pm 5.05V or \pm 10.1V, Lowpass filter (1kHz or 100kHz)
- ❑ Default Basic Mode from reset allows readings of individual channels from software directly with EOC being Polled/IRQ.
- ❑ Auto-scan Mode waits for an ext-trigger or software to start the pacer-clock to systematically run through each channel with its preset values and store the data into 1024 deep FIFO

Analog Outputs:

- ❑ 14-bit, 4-channels
- ❑ 10usec DAC settling time
- ❑ Each channel has a 1-pole reconstruction filter and output buffer
- ❑ \pm 10.1V output

Counter/Timer:

- ❑ 1Mhz 16-bit timer for pacer-clock
16C550-compatible

External Connections:

- ❑ 10/100BASE-T Ethernet port
- ❑ 50-pin header for analog input
- ❑ 16-pin header for digital/counter/timer I/O
- ❑ 10-pin header for analog output

Ordering Information:**OEM Single Board Computers:**

MPC565	16-bit, 16-channel analog input, digital I/O, non-DMA systems
MPC565-ET	16-bit, 16-channel analog input, digital I/O, non-DMA systems, -40°C to +85°C operating temp
565OPT11(ET)	16-bit, 32-channel analog input, digital I/O
565OPT12(ET)	14-bit, 4-channel analog output

Related Products:

CA5049	50-pin to 50-pin ribbon cable
CA4002	16-pin to 16-pin ribbon cable
CA5052	10-pin to 10-pin ribbon cable
TB5001	Breakout board, 50-point terminal strip

Cables nominally 15", other lengths available
Mathcad trademark MathSoft Engineering and Education, Inc.