

Tension-Clamp Ultra-Slim Signal Conditioners M6S Series

SIGNAL TRANSMITTER

(two isolated outputs)

Functions & Features

- Maintenance-free tension clamp connection
- 5.9-mm wide ultra-slim design
- Low profile allows the M6S module mounted in a 120-mm deep panel
- Galvanically isolates process instrumentation signals
- High-density mounting
- Power indicator LED
- UL approval

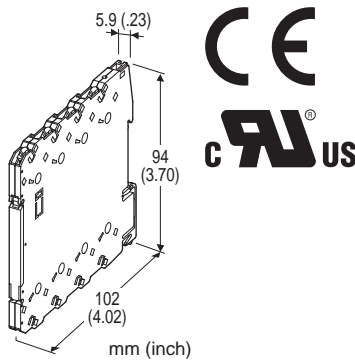

MODEL: M6SWVS-[1][2][3]-R[4]

ORDERING INFORMATION

- Code number: M6SWVS-[1][2][3]-R[4]
Specify a code from below for each [1] through [4].
(e.g. M6SWVS-AAA-R/K/UL)

[1] INPUT

Current

- A: 4 - 20 mA DC (Input resistance 50 Ω)
- B: 2 - 10 mA DC (Input resistance 100 Ω)
- C: 1 - 5 mA DC (Input resistance 200 Ω)
- D: 0 - 20 mA DC (Input resistance 50 Ω)
- E: 0 - 16 mA DC (Input resistance 50 Ω)
- F: 0 - 10 mA DC (Input resistance 100 Ω)
- G: 0 - 1 mA DC (Input resistance 1000 Ω)
- H: 10 - 50 mA DC (Input resistance 20 Ω)
- Z: Specify current (See INPUT SPECIFICATIONS)

Voltage

- 3: 0 - 1 V DC (Input resistance 1 M Ω min.)
- 4: 0 - 10 V DC (Input resistance 1 M Ω min.)
- 5: 0 - 5 V DC (Input resistance 1 M Ω min.)
- 6: 1 - 5 V DC (Input resistance 1 M Ω min.)
- 4W: -10 - +10 V DC (Input resistance 1 M Ω min.)

- 5W: -5 - +5 V DC (Input resistance 1 M Ω min.)
- 0: Specify voltage (See INPUT SPECIFICATIONS)

[2] OUTPUT 1

Current

- A: 4 - 20 mA DC (Load resistance 280 Ω max.)
- D: 0 - 20 mA DC (Load resistance 280 Ω max.)

Voltage

- 5: 0 - 5 V DC (Load resistance 5000 Ω min.)
- 6: 1 - 5 V DC (Load resistance 5000 Ω min.)

[3] OUTPUT 2

Same range availability as Output 1

Y: None

POWER INPUT

DC Power

- R: 24 V DC
(Operational voltage range 24 V \pm 10 %, ripple 10 %p-p max.)

[4] OPTIONS (multiple selections)

RESPONSE TIME (0 - 90 %)

- blank: Standard (\leq 0.5 sec.)
- /K: Fast Response (Approx. 3.5 msec.)

STANDARDS & APPROVALS

- blank: CE marking
- /UL: UL approval (CE marking)

GENERAL SPECIFICATIONS

Connection

Input and output: Tension clamp

Power input: Via the Installation Base (model: M6SBS)
or Tension clamp

Applicable wire size: 0.2 to 2.5 mm², stripped length 8 mm

Housing material: Flame-resistant resin (black)

Isolation: Input to output 1 to output 2 to power

Zero adjustment: -2 to +2 % (front)

Span adjustment: 98 to 102 % (front)

Power LED: Green light turns on when the power is supplied.

INPUT SPECIFICATIONS

- **DC Current:** Input resistor incorporated
Specify input resistance value for code Z.
($R \leq 0.125 \text{ W} \div [\text{F.S. Current}]^2$)
- **DC Voltage:** -30 - +30 V DC
- Minimum span:** 100 mV
- Offset:** Max. 1.5 times span
- Input resistance:** 1 M Ω min. (10 k Ω min. with no power supplied)

INSTALLATION

Power consumption: Approx. 0.6 W
Operating temperature: -20 to +55°C (-4 to +131°F)
Operating humidity: 30 to 90 %RH (non-condensing)
Mounting: Installation Base (model: M6SBS) or DIN rail
Weight: 60 g (2.1 oz)

PERFORMANCE in percentage of span

Accuracy: $\pm 0.1\%$
Temp. coefficient: $\pm 0.01\%/^{\circ}\text{C}$ ($\pm 0.006\%/^{\circ}\text{F}$)
Line voltage effect: $\pm 0.1\%$ over voltage range
Insulation resistance: $\geq 100\text{ M}\Omega$ with 500 V DC
Dielectric strength: 2000 V AC @1 minute (input to output
1 to output 2 to power to ground)

STANDARDS & APPROVALS

CE conformity:
EMC Directive (2004/108/EC)
EN 61000-6-4 (EMI)
EN 61000-6-2 (EMS)

Approval:
UL/C-UL nonincendive Class I, Division 2,
Groups A, B, C, and D hazardous locations
(ANSI/ISA-12.12.01, CAN/CSA-C22.2 No.213)
UL/C-UL general safety requirements
(UL 61010-1, CAN/CSA-C22.2 No.61010-1)

EXTERNAL VIEW

(With the cover open)

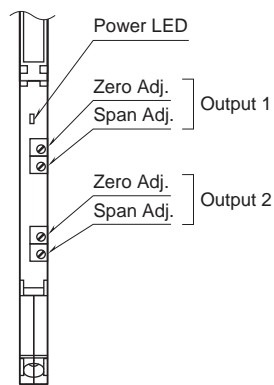

DIMENSIONS unit: mm (inch)

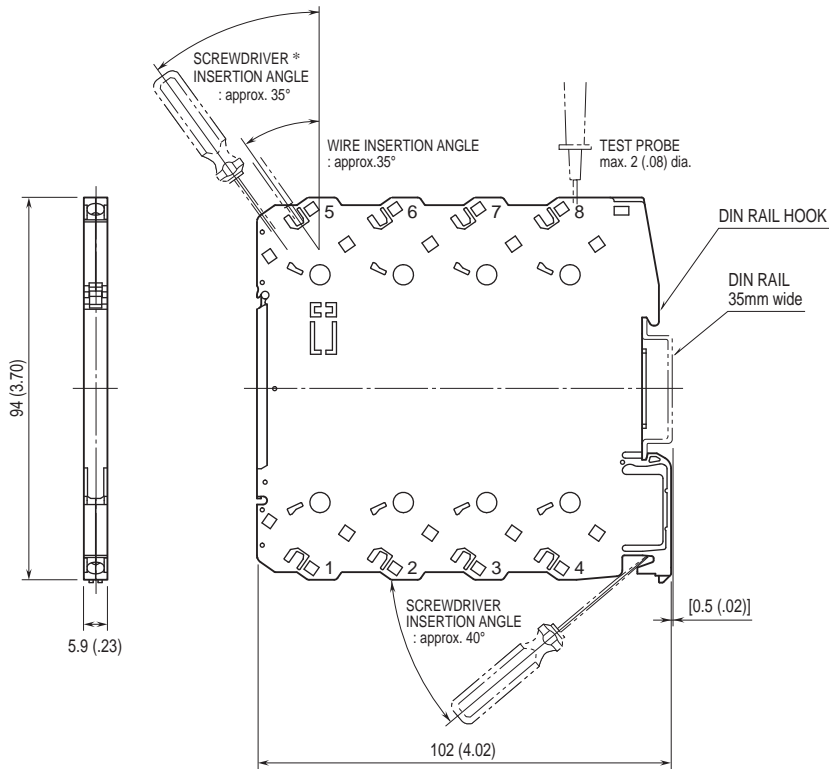

• When mounting, no extra space is needed between units.

*Use a minus screwdriver: tip width 3.8 mm max., tip thickness 0.5 to 0.6 mm

SCHEMATIC CIRCUITRY & CONNECTION DIAGRAM

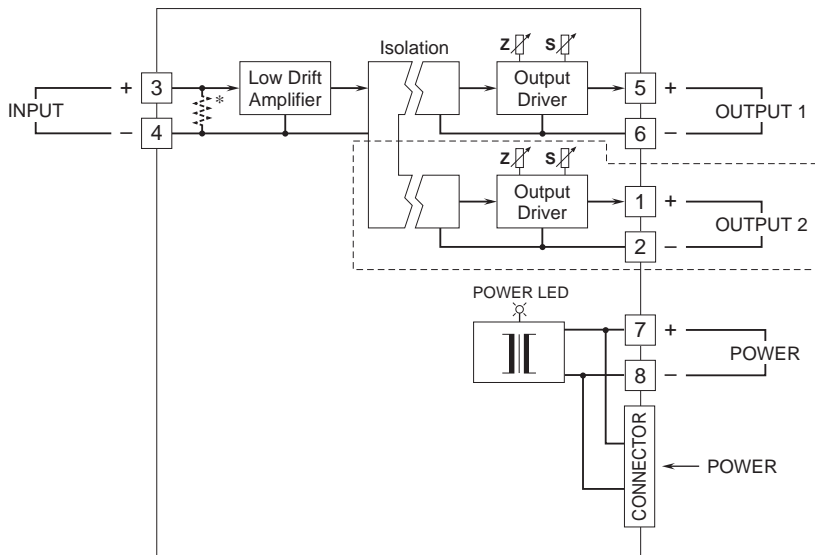

*Input shunt resistor incorporated for current input.

Remark: The section enclosed by broken line is only with 2nd output option.



Specifications are subject to change without notice.