

FPM-3170G

Industrial 17" SXGA Flat Panel Monitor with Direct-VGA Port, DVI, Video, S-Video



Features

- 17" SXGA TFT LCD with resolution up to 1280 x 1024
- Robust design with stainless steel chassis and aluminum front panel
- Hard anodic coating to prevent panel abrasion and acid corrosion
- Anti-reflective screen with tempered glass
- Supports stainless steel front panel (Customization)
- OSD control pad on front panel
- Supports industrial 24-48 V_{DC} power input (Optional)
- Supports transreflective LCD technology (Customization)
- Supports Panel, Wall, Desktop, Rack or VESA arm mounting
- NEMA4/IP65 Compliant
- RoHS Compliant

Introduction

FPM-3170G is a 17-inch color TFT LCD flat panel monitor specifically designed for industrial applications. With a viewing size as large as 17", it presents an ample display area as well as vivid and sharp images for your HMI. It features direct VGA signal transmission. You can thus upgrade the displays without making changes to the existing system. The onscreen display function also makes it easy to adjust the images on the screen. The whole chassis is designed in stainless steel and the front panel is made of aluminum with NEMA4/IP65 compliance.

Specifications

General

- **Button Controls** OSD (Onscreen Display) control pad on front panel
- **Certification** BSMI, CCC, CE, FCC-B
- **Dimension (W x H x D)** 482 x 354 x 68 mm (19" x 13.9" x 2.7")
- **Enclosure** Front panel : Aluminum with hard anodic coating.
Rear cover : Stainless steel chassis
- **Mounting** Panel, wall, desktop, VESA arm, or 19" rackmount with optional mounting kit
- **Power Input** External 50 W power adapter, with AC 100 V ~ 240 V input and DC +12 V @ 4.16 A output
- **Video Port** VGA, DVI-D, S-Video, Video
- **Weight (Net)** 9.25 kg (20.39 lbs)

LCD Display

- **Display Type** SXGA TFT LCD (CPT)
- **Display Size** 17"
- **Max. Resolution** 1280 x 1024
- **Max. Color** 16.2M
- **Viewing Angle (H, V)°** 140, 130
- **Luminance (cd/m²)** 300
- **Backlight Life (hrs)** 40,000
- **Contrast Ratio** 500 : 1

Touchscreen (Optional)

- **Sensor** ELO
- **Type** 5W Resistive
- **Interface** RS-232 or USB
- **Lifespan** 35 million touches at a single point
- **Light Transmission** 80%±5
- **OS Support** DOS, Windows® 95/98/ME/2000/XP/NT
- **Power Consumption** +5 V @ 100 mA
- **Touch Resolution** 4096 x 4096

Environment

- **Operation Temperature** 0 ~ 50° C (32 ~ 122° F)
- **Storage Temperature** -20 ~ 60° C (-4 ~ 140° F)
- **Humidity (Storage)** 10 ~ 95% non-condensing
- **Waterproof** IEC529 IP65 (Front Panel)
- **Vibration** 5 ~ 500 Hz, 1 Grms (Operating, Random)

Ordering Information

- **FPM-3170G-XBE** Ind.17" SXGA FPM w/D-VGA,DVI-D,S-V,Video Input
- **FPM-3170G-RBE** FPM-3170G-XBE w/Resistive TS (RS-232 interface)
- **FPM-3170G-UBE** FPM-3170G-XBE w/Resistive TS (USB Interface)
- **PWR-246E** Ind. DC to DC Converter w/24-48 V_{DC} Power Input

Dimensions

FPM-3170G

Unit: mm

Diameters of the rackmount holes:
Vertical: 6.5 mm
Horizontal: 9 mm

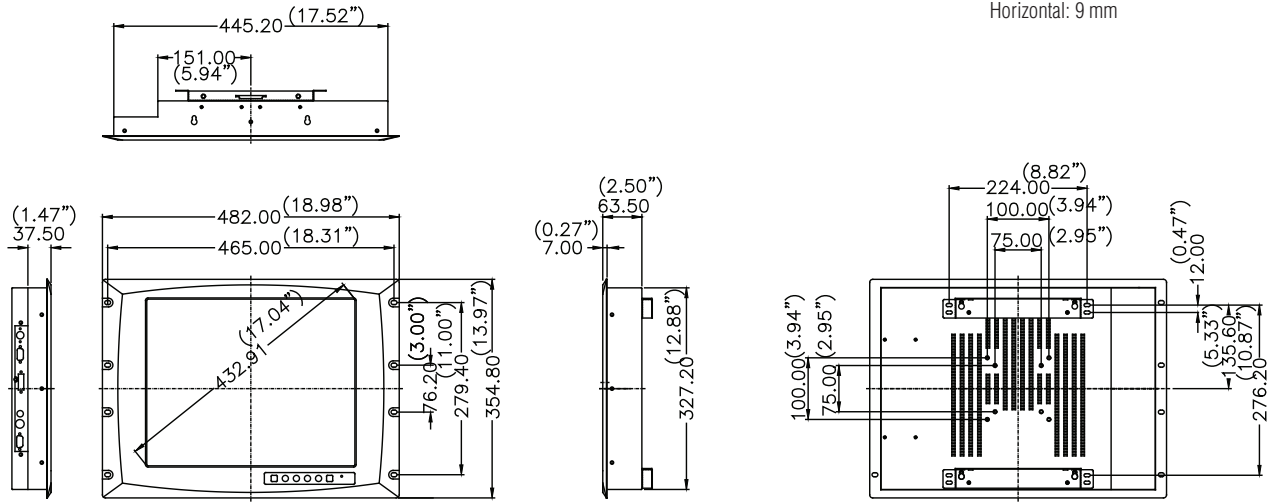

Cut out dimension 451 x 333 mm (17.75" x 13.38")

I/O View

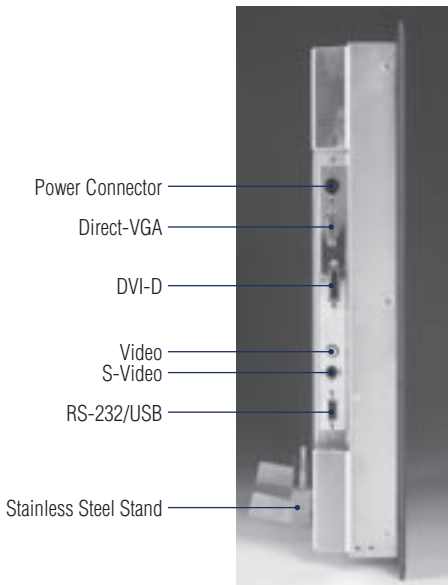

Mounting with DC Source

