

2111

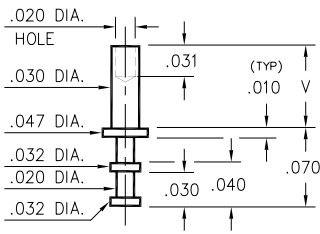

- X -	Board Thickness	Length V
1	.031	.053
2	.062	.084
3	.094	.115

2111-X-00-XX-00-00-07-0
Swage mount in .033 hole

2113

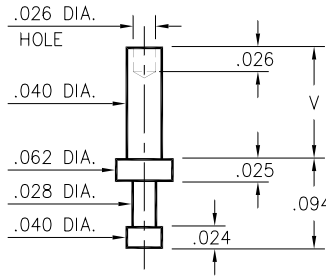

- X -	Board Thickness	Length V
1	.031	.053
2	.062	.084
3	.094	.115
4	.125	.147

2113-X-00-XX-00-00-07-0
Swage mount in .043 hole

2108

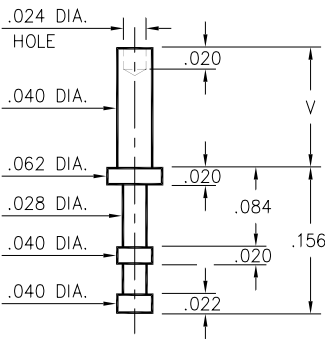

- X -	Board Thickness	Length V
1	.031	.053
2	.062	.084
3	.094	.115
4	.125	.147

2108-X-00-XX-00-00-07-0
Swage mount in .043 hole

2102

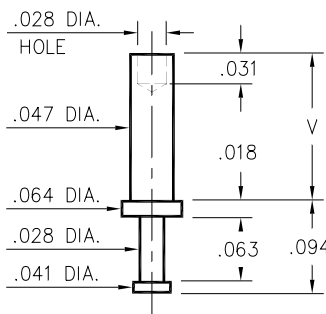

- X -	Board Thickness	Length V
5	.016	.035
1	.031	.054
2	.062	.084
3	.094	.115
4	.125	.147

2102-X-00-XX-00-00-07-0
Swage mount in .052 hole

2109

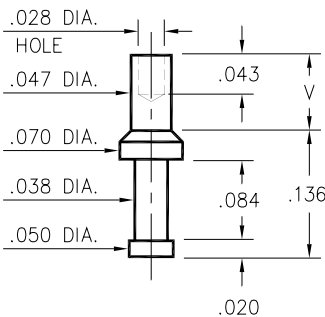

- X -	Board Thickness	Length V
1	.031	.052
2	.062	.085

2109-X-00-XX-00-00-07-0
Swage mount in .052 hole

2324

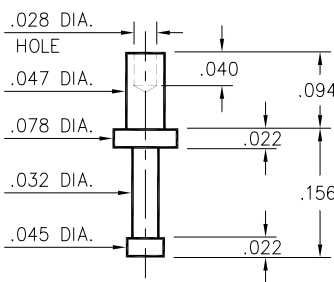

2324-2-00-XX-00-00-07-0
Swage mount in .052 hole
for .062 thick board

SPECIFICATIONS

PIN MATERIAL:
Brass Alloy 360, 1/2 Hard
Swage pins are annealed

DIMENSION IN INCHES
TOLERANCES ON:
LENGTHS: ±.005
DIAMETERS: ±.002
ANGLES: ± 2°

ORDER CODE: 2XXX - X - 00 - XX - 00 - 00 - 07 - 0

BASIC PART # →

SPECIFY PIN FINISH:
01 200μ" TIN/LEAD OVER NICKEL
44 300μ" SILVER OVER COPPER
50 300μ" ELECTRO-SOLDER
(60/40 SnPb)