

KEY FEATURES

High performance processor blade with four PMC sites

RoHS (5 of 6) compliant

1.8 GHz Intel Pentium M processor

Intel E7501 server-class chipset supporting 4.3GB/s memory bandwidth

Up to 4GB ECC-protected DDR266 SDRAM

Complete software operating environment including OS

PICMG 3.0 Gigabit Ethernet base interface support

PICMG 3.1, Option 1 and 2 fabric interface support

Multiple hard disk drive options

Service Availability™ Forum (SA Forum) compliant HPI and AIS software interfaces

Designed for NEBS and ETSI compliance

Designed for PICMG® 3.0 and 3.5 AdvancedTCA® compliant systems, the Motorola ATCA-7107 processor blade features the 1.8 GHz Intel® Pentium® M processor with a high MIPS/watt capability in an 8U form factor. It also includes an Intel® E7501 chipset with a memory bandwidth of 4.3GB/s, accommodates four PMC modules for additional processing power and/or I/O, and supports 4GB ECC-protected DDR266 SDRAM.

The ATCA-7107 blades are RoHS (5 of 6) compliant, eliminating the need for customers to incur the time, resource and expense associated with creating and/or converting existing product to meet this international requirement.

The ATCA-7107 blade features a managed, multi-layered 16-port Gigabit Ethernet switch that delivers the flexibility required for routing Gigabit Ethernet interfaces between the base board control processor, the PMC-based processing or I/O nodes, and the PICMG compliant base and fabric interfaces. The ATCA-7107 is available in two memory configurations (2GB and 4GB) and supports optional, on-board parallel and serial ATA hard drive devices; adding to the performance and flexibility of this processor blade.

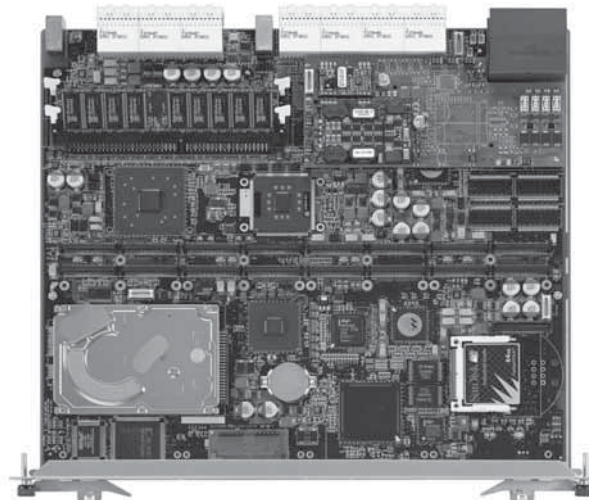

AdvancedTCA®

AdvancedTCA Processor Blade

The Motorola ATCA-7107 processor blade is designed to operate within both the Motorola Centellis™ 3000 and Avantellis™ 3000 series of communications servers. The Intel Pentium M processor delivers outstanding performance and supports light I/O and/or coprocessing via PMC sites; making it ideal for implementing almost any control plane applications.

ATCA-7107, R3

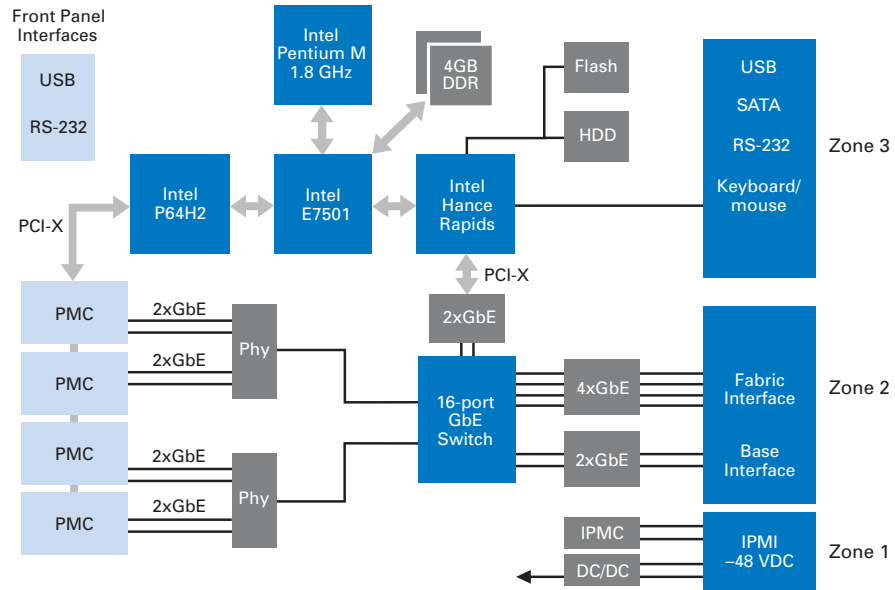
BLOCK DIAGRAM



STANDARD NETWORKING SUPPORT

The ATCA-7107 processor blade provides PICMG 3.0 base interface connectivity in a dual star configuration using standard Gigabit Ethernet technology. The PICMG 3.1 fabric interface is also supported and several configurations are available depending on application bandwidth requirements.

PICMG 3.1, Option 1 – Single, redundant Gigabit Ethernet pair (1.0Gbps)

PICMG 3.1, Option 2 – Dual, redundant Gigabit Ethernet pairs (2.0Gbps)

PROCESSOR COMPLEX

Surrounding the Intel Pentium M processor is an array of high performance components that combine to form a powerful processor complex.

FEATURES INCLUDE:

Up to 4GB, ECC-protected DDR2 SDRAM.

Intel E7501 server-class chipset supporting 4.3GB/s memory bandwidth

1.0MB boot flash

Parallel and SATA hard disk drive options

SOFTWARE SUPPORT

All Motorola ATCA blades can be configured with optional software that, when combined with the hardware, create a fully integrated and verified telecom platform. Two software packages are available:

Centellis 3000 software package
Avantellis 3000 software package

The Centellis-Avantellis 3000 platforms come complete with, and are verified with, a standard Carrier Grade Linux (CGL) distribution; MontaVista CGE 4.0, the market leader in Carrier Grade Linux. MontaVista CGE 4.0 comes complete with all required Linux Support Packages (LSPs) to support Motorola ATCA blades as well as several userland applications.

The Centellis 3000 software package comes complete with:

MontaVista CGE 4.0
Basic Blade Services

Basic Blades Services (BBS) software is provided to enable a set of ATCA hardware and software components into a fully integrated and verified telecom platform – the Centellis 3000 platform. This platform is ready for customers HA middleware and application environment.

Basic Blade Services (generic to all ATCA blades):

Hardware Platform Management including local IPMC,
LED, EKeying and blade extraction software
Firmware upgrade utility
Local management access (SNMP, CLI)

The Avantellis 3000 software package comes complete with:

MontaVista CGE 4.0
Platform Control Software
NetPlane® Core Services

NetPlane Core Services (NCS) is Motorola's SA Forum compliant HA middleware combined with select complimentary services to create a complete service availability solution. Platform Control Software (PCS) is lower level software that binds the platform independent NCS software to the specific hardware platform. These software packages, combined with MontaVista CGE 4.0, provide a high availability platform ready for customer applications – the Avantellis 3000 platform.

RELEVANT STANDARDS

Open Source Development Labs (OSDL), rev. 1.0
SA Forum

- Hardware Platform Interface (HPI) – rev. 1.0, A .01.01
- Application Interface Specification (AIS) – rev. 1.0, A .01.01

For more information on the Centellis and Avantellis 3000 platforms, please refer to the Centellis 3000 and Avantellis 3000 series datasheets.

INTELLIGENT PLATFORM MANAGEMENT CONTROL

The PICMG 3.0 AdvancedTCA standard specifies a low-level, environmental management architecture referred to as intelligent platform management interface (IPMI). The ATCA-7107 blade implements this functionality using an off-the-shelf hardware and software based IPM controller that monitors all local, blade-specific environmental information. Management access to this information is provided through the SA Forum defined HPI interface.

REAR TRANSITION MODULES

Motorola offers a rear transition module (RTM) for the ATCA-7107 processor blade for access to an assortment of interfaces like USB, keyboard/mouse as well as SATA storage interfaces.

PMC SITE

The ATCA-7107 blade provides four, single width IEEE1386.1-2001 PMC sites. The PMC site supports PCI-X 64-bit 133 MHz capable PMC modules. These can be used for any combination of processor, coprocessor or I/O functions.

PROCESSOR

1.8 GHz Intel Pentium M Processor
 512KB L2 on-chip cache
 400 MHz frontside bus
 Intel E7501 system controller

MEMORY

Up to 4GB, ECC-protected SDRAM. Supported configurations – 2GB and 4GB
 256Byte CMOS NVRAM for BIOS configuration
 1.0MB boot flash, single bank architecture
 1.0MB backup boot flash (can alternatively be used as application flash)
 Support for CompactFlash card

COUNTERS/TIMERS

Real-time clock
 Programmable watchdog timer

PCI MEZZANINE CARD

Four PMC sites with 100 MHz PCI-X interface and dual Gigabit Ethernet interface

BASE AND FABRIC INTERFACES

Dual star configuration
 PICMG 3.0 base interface compliant, Gigabit Ethernet (1.0Gbps)
 PICMG 3.1 fabric interface compliant, Gigabit Ethernet
 – PICMG 3.1, Option 1 – Single, redundant Gigabit Ethernet pair (1.0Gbps)
 – PICMG 3.1, Option 2 – Dual, redundant Gigabit Ethernet pairs (2.0Gbps)

EXTERNAL INTERFACES

Front Panel
 – USB 2.0, mini USB Type AB (2)
 – Serial, RJ-45 (2)
 – Keyboard/mouse, PS2 (1)
 Via Optional RTM
 – USB 2.0, Type A (2); Serial, RJ-45 (2); SATA (1).
 – From PTMC: E1/T1, RJ-45 (16); Serial, RJ-45 (2)
 – Keyboard/mouse, PS2 (1)

POWER REQUIREMENTS

Dual-redundant –48V rails
 Input range: 39.5 – 72 VDC
 Typical power: 120 – 140W

THERMAL CHARACTERISTICS

Operating range: –5° C to 55° C

BLADE SIZE

8U form factor, 280 mm X 322.5 mm, single slot

RELEVANT STANDARDS

PICMG 3.0 (form factor, IPMI, base interface, hot swap, RTM)
 PICMG 3.1, Option 1 and 2

ORDERING INFORMATION

Part Number	Description
ATCA-7107/2G/5E	ATCA processor blade with Intel Pentium M processor, 2GB memory and 4 PMC slots (RoHS 5/6)
ATCA-7107/4G/5E	ATCA processor blade with Intel Pentium M processor, 4GB memory and 4 PMC slots (RoHS 5/6)
RTM-ATCA-7107/5E	RTM for the ATCA-7107 blade (RoHS 5/6)
ATCA-7107/HDD/6E	30GB IDE PATA HDD and mounting kit for the ATCA-7107 (RoHS 6/6)
ATCA-7107/HD-SATA/6E	30GB IDE SATA HDD and mounting kit for the ATCA-7107 (RoHS 6/6)
ATCA-CMC-MODULE/6E	Provides serial interfaces (COM1 and COM3) and keyboard/mouse on the front panel of ATCA-7107, mounted in PMC site #4 (RoHS 6/6)
CABLE/PMC/RJ45/6E	Adapter cable - single RJ-45 plug to dual RJ-45 sockets (RoHS 6/6)
CABLE/USB/6E	Adapter cable - mini USB B-male to USB A-female (needed to connect e.g., a disk drive to front panel of ATCA-7107) (RoHS 6/6)
CABLE/RJ45/DSUB/6E	Adapter cable - RJ-45 to DSUB9 female (needed to connect e.g., a laptop to serial interface of ATCA-7107) (RoHS 6/6)

REGULATORY COMPLIANCE

Item	Description
Designed to comply with NEBS	GR-63-CORE, NEBS Physical Protection, Level 3
	GR-1089-CORE, Electromagnetic Compatibility and Electrical Safety — Generic Criteria for Network Telecommunications Equipment. Level 3, Equipment Type 2
Designed to comply with ETSI	ETSI Storage, ETS 300 019-2-1, Class 1.2 equipment, Not Temperature Controlled Storage Locations
	ETSI Transportation, ETS 300 019-2-2, Class 2.3 equipment, Public Transportation
	ETSI Operation, ETS 300 019-2-3, Class 3.2 equipment, Partly Temperature Controlled Locations
Designed to comply with Acoustic	ETS-300-753, Equipment Engineering (EE); Acoustic noise emitted by telecommunications equipment
EMC	EN-300-386 Electromagnetic compatibility and Radio spectrum Matters (ERM); telecommunication network equipment; ElectroMagnetic Compatibility (EMC) requirements, Telecommunication equipment room (attended)
	FCC 47 CFR Part 15 Subpart B (US), Class A
	EMC Directive 89/336/EEC (EU)
	AS/NZS 3548 (Australia/New Zealand), Limits and Methods of Measurement of Radio Disturbance Characteristics of Information Technology Equipment
	VCCI Class A (Japan), Voluntary Control Council for Interference by Information Technology Equipment
Safety	Compliance to UL/CSA 60950-1, EN 60950-1 and IEC 60950-1 CB Scheme. Marked with U.S. NRTL, Canadian Safety and CE Mark. Safety of information technology equipment, including electrical business equipment
	ETS 300-132-2 Environmental Engineering (EE); Power supply interface at the input to telecommunications equipment; Part 2: Operated by direct current (dc)
RoHS/WEEE compliance	DIRECTIVE 2002/95/EC OF THE EUROPEAN PARLIAMENT AND OF THE COUNCIL on the restriction of the use of certain hazardous substances in electrical and electronic equipment (RoHS)
	DIRECTIVE 2002/96/EC OF THE EUROPEAN PARLIAMENT AND OF THE COUNCIL on waste electrical and electronic equipment (WEEE)

SOLUTION SERVICES

Motorola provides a portfolio of solution services optimized to meet your needs throughout the product lifecycle. Design services help speed time-to-market. Deployment services include global 24x7 technical support. Renewal services enable product longevity and technology refresh. And solution extras include enhanced warranty and repairs.

Sales Offices

Tempe, AZ U.S.A. 1 800 759 1107 or +1 602 438 5720
 Paris, France +33 1 69 35 25 88
 Munich, Germany +49 89 608 14-0
 Loughborough, UK +44 1509 634300

Tel Aviv, Israel +972 3 568 4385
 Shanghai, China +86 215292 5693
 Tokyo, Japan +81 3 5424 3101
 Hong Kong, China +852 2966 3209

This document identifies products, their specifications, and their characteristics, which may be suitable for certain applications. It does not constitute an offer to sell or a commitment of present or future availability, and should not be relied upon to state the terms and conditions, including warranties and disclaimers thereof, on which Motorola may sell products. A prospective buyer should exercise its own independent judgment to confirm the suitability of the products for particular applications. Motorola reserves the right to make changes, without notice, to any products or information herein which will, in its sole discretion, improve reliability, function, or design. Motorola does not assume any liability arising out of the application or use of any product or circuit described herein; neither does it convey any license under its patent or other intellectual property rights or under others. This disclaimer extends to any prospective buyer, and it includes Motorola's licensee, licensee's transferees, and licensee's customers and users. Availability of some of the products and services described herein may be restricted in some locations.



www.motorola.com/computing

MOTOROLA and the Stylized M Logo are registered in the U.S. Patent and Trademark Office. PICMG, AdvancedTCA and the AdvancedTCA logo are registered trademarks of the PCI Industrial Computer Manufacturers Group. Service Availability is a proprietary trademark used under license. Intel and Pentium are trademarks or registered trademarks of Intel Corporation or its subsidiaries in the United States and other countries. All other product or service names are the property of their respective owners.
 © Motorola, Inc. 2006

ATCA7107-D0 06/06