

## Screw Terminal Ultra-Slim Signal Conditioners M6N Series

### SIGNAL TRANSMITTER

(PC programmable)

#### Functions & Features

- 7.5-mm wide ultra-slim design
- Low profile allows the M6N module mounted in a 120-mm deep panel
- Converts a DC input into a standard process signal
- PC programmable
- High-density mounting
- Power indicator LED
- UL approval

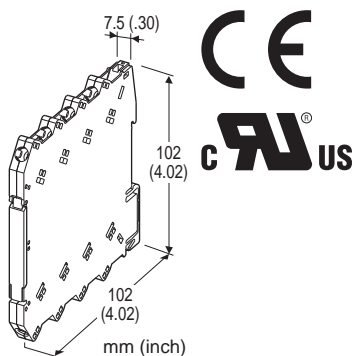

### MODEL: M6NXV-[1][2]-R[3]

#### ORDERING INFORMATION

- Code number: M6NXV-[1][2]-R[3]  
Specify a code from below for each [1] through [3].  
(e.g. M6NXV-Z1Z1-R/UL)
- Input range (e.g. 4 - 20 mA DC)
- Output range (e.g. 4 - 20 mA DC)

#### [1] INPUT

##### Current

**Z1:** Range 0 - 50 mA DC (Input resistance 24.9 Ω)

##### Voltage

**S1:** Range -1000 - +1000 mV DC (Input resistance 1 MΩ min.)

**S2:** Range -10 - +10 V DC (Input resistance 1 MΩ min.)

(Configurator software is used to change the input type and precise range.)

#### [2] OUTPUT

##### Current

**Z1:** Range 0 - 20 mA DC

##### Voltage

**V2:** Range -10 - +10 V DC

**V3:** Range -5 - +5 V DC

(Configurator software is used to change output over the described range of the selected suffix code.

For changing between suffix codes, set the Output Range Selector on the side of unit before software adjustment.)

#### POWER INPUT

##### DC Power

**R:** 24 V DC

(Operational voltage range 24 V ±10 %, ripple 10 %p-p max.)

#### [3] OPTIONS

##### STANDARDS & APPROVALS

**blank:** CE marking

**/UL:** UL approval (CE marking)

#### RELATED PRODUCTS

- PC configurator software (model: M6CFG)

Downloadable at M-System's web site.

A dedicated cable is required to connect the module to the PC. Please refer to the internet software download site or the users manual for the PC configurator for applicable cable types.

#### GENERAL SPECIFICATIONS

##### Connection

**Input and output:** M3 screw terminal (torque 0.5 N·m)

**Power input:** Via the Installation Base (model: M6NBS) or M3 screw terminal (torque 0.5 N·m)

**Recommended solderless terminal:** Max. 5.8 mm (0.23") wide; Ones with insulation sleeve do not fit.  
Applicable wire size 0.2 - 2.5 mm<sup>2</sup>

**Housing material:** Flame-resistant resin (black)

**Isolation:** Input to output to power

**Overrange output:** -2 - +102 %

(Negative current output is not available.)

**Zero adjustment:** -2 to +2% (PC programming)

**Span adjustment:** 98 to 102% (PC programming)

**Power LED:** Green light turns on when the power is supplied.

**Status indicator LED:** Orange LED; Flashing patterns indicate different operating status of the transmitter.

**Programming:** Downloaded from PC; input type and range, output type and range, zero and span, user's linearization table (max. 101 points, specified within -2 to +102% for both input and output), etc.

For detailed information, refer to the users manual for the PC configurator.

**Configurator connection:** 2.5 dia. miniature jack; RS-232C level

## Recommended solderless terminal

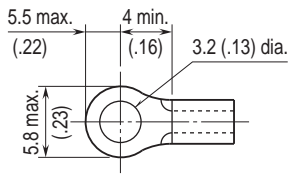

## INPUT SPECIFICATIONS

- **DC Current:** Input resistor incorporated  
(If not specified, the input range is 4 - 20 mA DC.)  
**Input range:** 0 - 50 mA DC  
**Minimum span:** 2 mA  
**Offset:** Lower range can be any specific value within the input range provided that the minimum span is maintained.
- **DC Voltage**  
**Code S1 (narrow spans)**  
**Input range:** -1000 - +1000 mV DC  
**Minimum span:** 100 mV  
**Code S2 (wide spans)**  
**Input range:** -10 - +10 V DC  
**Minimum span:** 1 V  
**Offset:** Lower range can be any specific value within the input range provided that the minimum span is maintained.  
If not specified, the input range is shown below.  
S1: 0 - 100 mV DC  
S2: 1 - 5 V DC

## OUTPUT SPECIFICATIONS

- **DC CURRENT**  
**Output range:** 0 - 20 mA DC  
**Conformance range:** 0 - 20.4 mA DC  
**Minimum span:** 1 mA  
**Offset:** Lower range can be any specific value within the output range provided that the minimum span is maintained.  
**Load resistance:** Output drive 11 V max.  
(e.g. 4 - 20 mA: 550 Ω [11 V/20 mA])  
If not specified, the output range is 4 - 20 mA DC.
- **DC VOLTAGE**  
**Code V2 (wide spans)**  
**Output range:** -10 - +10 V DC  
**Conformance range:** -10.4 - +10.4 V DC  
**Minimum span:** 1 V  
**Code V3 (narrow spans)**  
**Output range:** -5 - +5 V DC  
**Conformance range:** -5.2 - +5.2 V DC  
**Minimum span:** 0.5 V  
**Offset:** Lower range can be any specific value within the output range provided that the minimum span is maintained.  
**Load resistance:** Output drive 1 mA max.

- (e.g. 1 - 5 V: 5000 Ω [5 V/1 mA])  
If not specified, the output range is shown below.  
V2: 0 - 10 V DC  
V3: 1 - 5 V DC

## INSTALLATION

- Power consumption:** Approx. 0.5 W  
**Operating temperature:** -20 to +55°C (-4 to +131°F)  
**Operating humidity:** 30 to 90 %RH (non-condensing)  
**Mounting:** Installation Base (model: M6NBS) or DIN rail  
**Weight:** 65 g (2.3 oz)

## PERFORMANCE in percentage of span

- Overall accuracy:** Input accuracy + output accuracy  
Inversely proportional to the span.  
See CALCULATION EXAMPLES OF OVERALL ACCURACY.
- **Input accuracy:** (% of max. input range)  
-1000 - +1000 mV : ±0.01 %  
-10 - +10 V : ±0.01 %  
0 - 50 mA : ±0.02 %
  - **Output accuracy:** ±0.04 % of max. output range
  - Temp. coefficient:** ±0.01 %/°C (±0.006 %/°F) of max. span
  - Response time:** ≤ 0.5 sec. (0 - 90 %)
  - Line voltage effect:** ±0.1 % over voltage range
  - Insulation resistance:** ≥ 100 MΩ with 500 V DC
  - Dielectric strength:** 2000 V AC @1 minute (input to output to power to ground)

## CALCULATION EXAMPLES OF OVERALL ACCURACY

- [Example] Input Type -10 - +10 V, Input Range 1 - 5 V,  
Output Type -5 - +5 V, Output Range 1 - 5 V
- Input accuracy = Max. Input Range (20 V) / Span (4 V) × 0.01 % = 0.05 %
  - Output accuracy = Max. Output Range (10 V) / Span (4 V) × 0.04 % = 0.1 %
- Accuracy = ±0.15 %

## STANDARDS & APPROVALS

- CE conformity:**  
EMC Directive (2004/108/EC)  
EN 61000-6-4 (EMI)  
EN 61000-6-2 (EMS)
- Approval:**  
UL/C-UL nonincendive Class I, Division 2,  
Groups A, B, C, and D hazardous locations  
(ANSI/ISA-12.12.01, CAN/CSA-C22.2 No.213)  
UL/C-UL general safety requirements  
(UL 61010-1, CAN/CSA-C22.2 No.61010-1)

## EXTERNAL VIEW

■ FRONT VIEW (with the cover open)

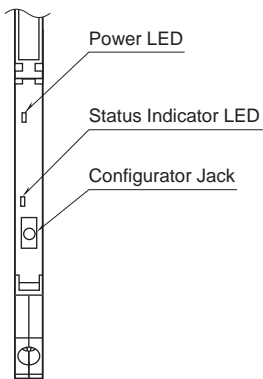

■ SIDE VIEW

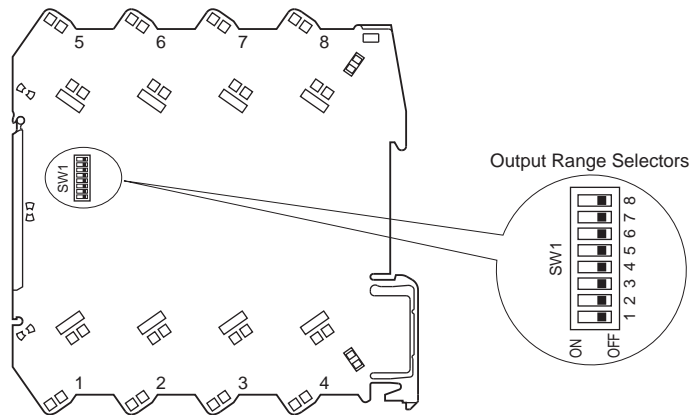

The DIP switch setting is required to select output types before setting a precise output range using PC Configurator Software (model: M6CFG). Refer to the instruction manual for detailed procedures.

## DIMENSIONS unit: mm (inch)

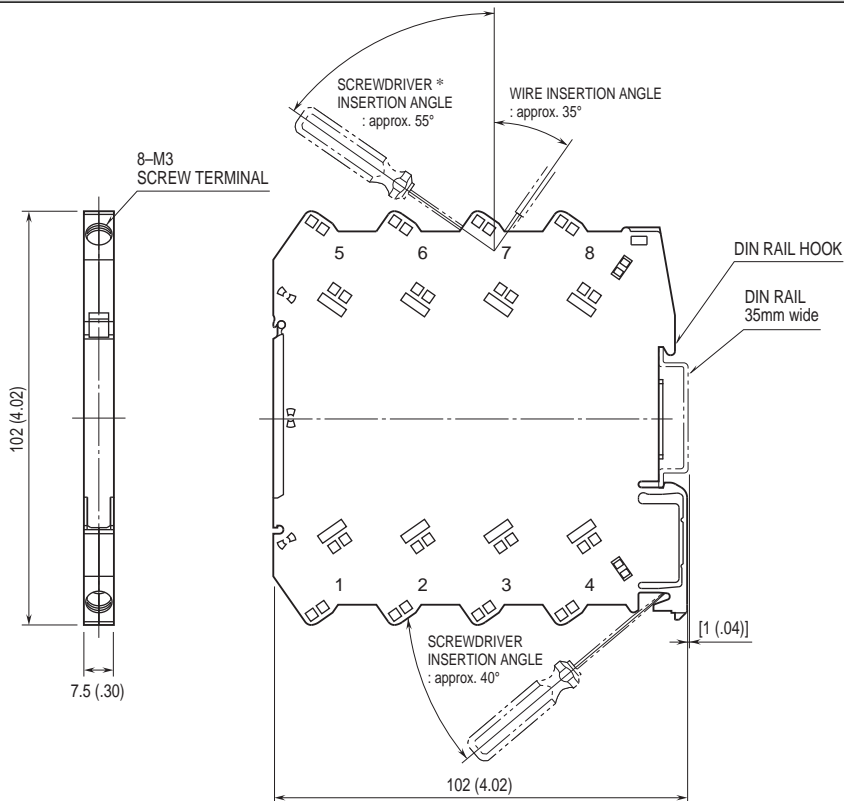

\*Screwdriver stem diameter: 6 mm (.24") or less

• When mounting, no extra space is needed between units.

**SCHEMATIC CIRCUITRY & CONNECTION DIAGRAM**

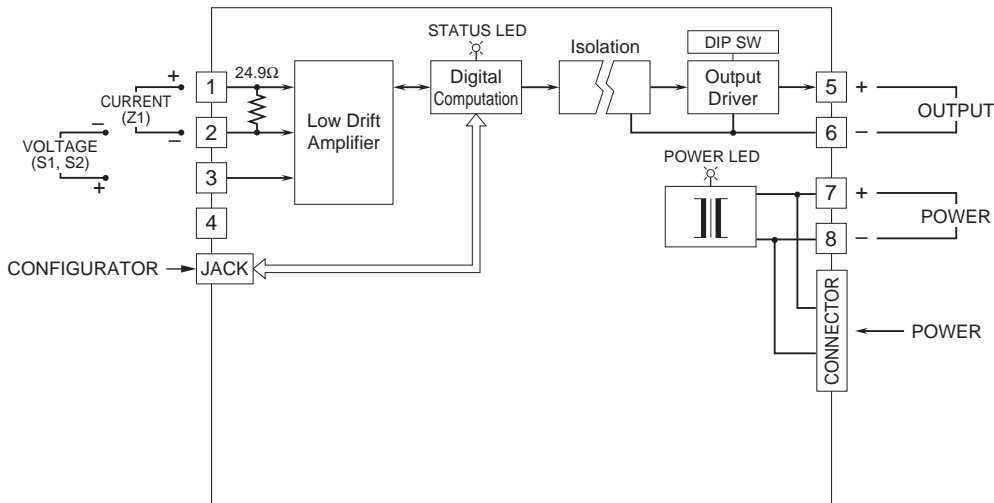

Specifications are subject to change without notice.