

# IPC-6608

## 8-slot Desktop/Wallmount Chassis with PS/2 Power Supply



### Features

- Equipped with an 8-slot ISA or ISA/PCI backplane to hold eight full-length cards
- Two front accessed 5.25" half-height disk drives and one 3.5" FDD
- High pressure cooling fan supports abundant cooling and streamlined ventilation
- Vibration protected driver mounting for industrial applications

### Introduction

Specifically designed for factory floors and other harsh industrial environments, IPC-6608 Wall-mount industrial computer chassis is ideal for system integrators or users who require a compact, rugged PC/AT compatible system. IPC-6608 features an 8-slot passive backplane and a wide selection of power supplies to meet different application needs. The chassis is only 6.8" wide and can easily be mounted bi-directionally on panels or walls with the supplied bracket.

### Specifications

Drive Bay	3.5"	Front-accessible 1
	5.25"	2
Cooling	Fan	1 (hot-swap, 84 CFM)
	Air Filter	Yes
Miscellaneous	Control	Front panel power switch and reset switch
	Indicator	LEDs for power On/Off and HDD activity
Environment	Temperature	0 ~ 40 °C (32 ~ 104 °F), operating
	Humidity	10 ~ 95 % @ 40 °C, non-condensing
Physical	Dimensions (W x H x D)	173 x 315 x 410 mm (6.8" x 12.4" x 16.1")
	Weight	5.6 Kg (12.3 lb)

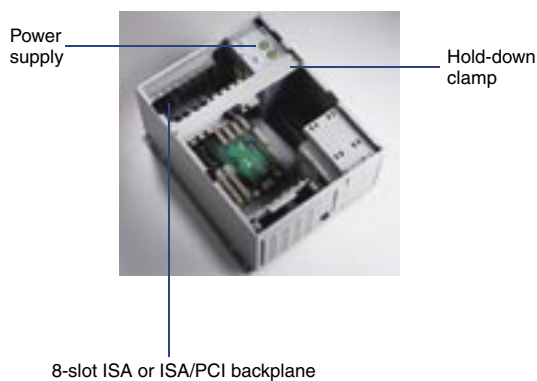
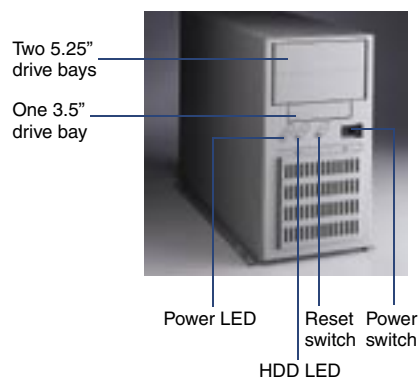

### Dimension Diagram

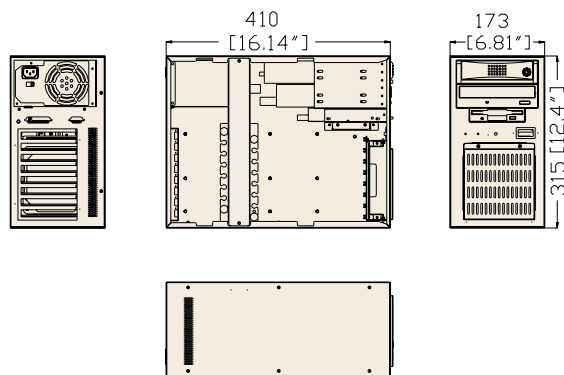

Unit: mm (inch)

### Installation

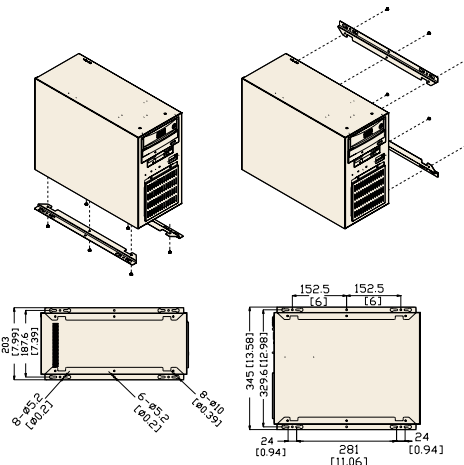

Unit: mm (inch)

### Power Supply Options

Part Number	Watt	Input	Output	Specifications		
				Mini-load	Safety	MTBF
PS-250ATX-Z (ATX, PFC)	250 W	AC 95 ~ 132 V AC 190 ~ 264 V (Selectable)	+5 V @ 27 A +3.3 V @ 20 A +12 V @ 13 A -12 V @ 0.8 A -5 V @ 0.3 A +5 Vsb @ 2 A	+5 V @ 0.5 A +12 V @ 0.3 A	UL/cUL (60950 3rd) CE (EN61000-3-2 Class D) TUV/FCC/CSA/Nemko CB/CCC	100,000 hours @ 25 °C full load
PS-260-610E (AT)	260 W	AC 110/220 V	+5 V @ 25 A +12 V @ 9 A -5 V @ 0.5 A -12 V @ 2 A	+5 V @ 1 A +12 V @ 0.1 A	UL/cUL/CSA/CE/FCC/TUV	140,000 hours @ 50 °C full load
RPS-250-SDTB (AT)	230 W/200 W @ 40 °C	AC 110/220 V	+5 V @ 25 A +12 V @ 12 A -5 V @ 1 A -12 V @ 1 A	+5 V @ 4 A +12 V @ 1 A	UL/cUL/CE/FCC/CSA/TUV	250,000 hours @ 30 °C full load
PS-300ATX-ZB (ATX, PFC)	300 W	AC90-264 V (Full-range)	+5 V @ 30 A +3.3 V @ 28 A +12 V @ 15 A -12 V @ 0.8 A -5 V @ 0.3 A +5 Vsb @ 2 A	+5 V @ 0.1 A +3.3 V @ 0.3 A	UL/cUL (60950 3rd) CE (EN61000-3-2 Class D) TUV/FCC/CSA/Nemko CB/CCC	100,000 hours @ 25 °C

### Passive Backplane Options

Part Number	Slot	Segment
PCA-6108E-0C1	8 ISA	Single
PCA-6108P4-C	3 ISA, 3 PCI, 1 PICMG/PCI, 1 PICMG	Single
PCA-6108P6-0B3	1 ISA, 5 PCI, 1 PICMG/PCI, 1 PICMG	Single
PCA-6108P6X-0A1	6 PCI, 2PICMG	Single
PCA-6108P8-0A1	8 PCI	Single

### Ordering Information

Part Number	With Power Supply	With Backplane	Regulation
IPC-6608BP-00	Without power supply, with AT/ATX switch both	--	None
IPC-6608BP-25Z	PS-250ATX-Z	--	UL, cUL, CE
IPC-6608BP-26P	PS-260-610E	--	UL, cUL
IPC-6608BP-30Z	PS-300ATX-ZB	--	UL, cUL, CE
IPC-6608BP-25R	RPS-250-SDTB	--	None