

High-speed line driver output 4 axes motion control board for PCI

SMC-4DL-PCI



* Specifications, color and design of the products are subject to change without notice.

This product is a PCI bus-standard motion control board that can position a stepping motor or (a pulse-train input type of) servomotor.

This product has the functions for positioning, origin return, linear interpolation, and for S-curve acceleration and deceleration, capable of multi-axial linear interpolation and speed/position overriding.

This product covers a wide range of applications including semiconductor equipment, test instruments, multi-axis robots, and X-Y robots.

This product can control up to four axes alone.

Using the bundled driver library [API-PAC(W32)], you can create Windows application software for this board in your favorite programming language supporting Win32 API functions, such as Visual Basic or Visual C++.

About Migration From The Existing Products

This product cannot use [API-SMC(98/PC)] (CD-ROM attached) which is the driver software for the existing products SMC-2P(PCI), SMC-4P(PCI), and SMC-3(PC). [API-SMC(98/PC)] (bundled CD-ROM) cannot be used. Please use [API-SMC(WDM)] (bundled CD-ROM) which is the driver software for this product. As a reference material when migrating from the existing products to this product, "Migration guide" which summarizes migration methods and differences about initial settings and API function units is provided. Please use the guide for your reference.

"Migration guide" can be downloaded from the download library of CONTEC's Web site (<http://www.contec.com/download>)

Features

Capable of multi-axis independent control and pulse output up to 9.8Mpps

Control for up to 4 axes and motor control pulse output up to 9.8Mpps are available.

Command pulse for motor control supports common pulse, independent pulse and 90° phase difference pulse.

Limit input 3channels/axis, general-purpose input 7channels/axis, and general-purpose output 3channels/axis are equipped. Also, depending on the software setting, 5 general-purpose inputs can be used as alarm inputs, and general-purpose outputs as deviation counter clear outputs.

Capable of controlling the jogging at fixed speed or by linear/S-curve acceleration and deceleration, positioning, and origin returning

Carrying a motor control IC in the PCL6100 series from Nippon Pulse Motor Co., Ltd., capable of controlling jogging, positioning, origin returning, synchronization control and linear interpolation

Provided with various input/output formats enabling connection to an encoder input circuit as well as pulse output circuit.

Encoder input circuits can be connected with differential output, TTL level output, and open-collector output. Pulse output circuits can be connected with differential input, opto-coupler and TTL level input.

With the multi-axis synchronization control function, capable of aligning the timing for operation start and end

Synchronization control of multi-axis simultaneous start/stop control, linear interpolation operation is available.

Capable of speed and position overriding

Capable of changing the speed and target position during operation

Comparator circuits allowing the set value and counter value to be compared

A pair of comparator circuits is provided for each axis, allowing the set value and counter value to be compared with each other. They also allow signals to be output while comparator conditions are met.

Provided with seven general-purpose input pins and three general-purpose output pins per axis

Seven general-purpose inputs are provided for each axis, five of which are also available as alarm, positioning completion, deceleration stop, counter latch, and positioning start inputs. Logic can be changed by software.

Three output pins are provided for each axis. The output signals can be switched among alarm clear output, driver deviation clear output and comparator output by the software. Logic can be changed by software.

Dedicated terminal strip CCB-SMC2 (option) available focusing on the ease of use for wiring

A dedicated terminal strip CCB-SMC2 (option) which assigns signals for each axis is provided. Driver units and limit sensors for stepping motors and servo motors can be connected up to 4 pieces.

Specification

Common Section

Item	Specification
Control target	Stepping motor or servo motor driver unit(pulse train input type)
Number of axes to control	4 axes
Device used	PCL6143 (Nippon Pulse Motor CO., LTD.) or equivalence to it
Interrupt	1 ch
Interrupt factor	At the time of stop by positive-direction end limit input ON At the time of stop by negative-direction end limit input ON At the time of stop by alarm input on At the time of stop by simultaneous stop operation At the time of stop by deceleration (decelerated stop) input on At the time of occurring the encoder input error The other event (setting by the software)
I/O address	Any 128 ports boundary
Current consumption (Max.)	5VDC 700mA
Operating condition	0 - 50°C, 10 - 90% (No condensation)
PCI bus specification	32-bit, 33MHz, Universal key shapes supported *1
Dimension (mm)	176.41(L) x 106.68(H)
Connector used	HDRA-EC100LFD+ [made by HONDA TSUSHIN KOGYO CO., LTD.] or equivalence to it
Weight	100g

*1 This board requires power supply at +5 V from an expansion slot (it does not work on a machine with a +3.3V power supply alone).

Encoder Input Section

Item	Specification
Encode type	Incremental
Maximum counter value	8000000h - 7FFFFFFh(-134,217,728 - 134,217,727), 28 bit
Input signal type	Single-phase input (UP/DOWN/Z) / Phase input(A/B/Z)
Supported output type	Differential output, TTL level output, open-collector output
Device used	AM26LS32A(T.I) or equivalence to it
Terminal resistor	150Ω (Separable with SW)
Receiver input sensitivity	±200mV
In-phase input voltage range	±7V
Distance in which signal can be extended	10m (Depending on the time of connecting the differential output, wiring environment and input frequency) 3m (Depending on the time of connecting the open-collector output, wiring environment and input frequency) 1.5m (Depending on the time of connecting the TTL level output, wiring environment and input frequency)
Response frequency	5MHz (Depending on the time of connecting the differential output, two-phase input, multiply by 4, duty 50%), 3MHz (Depending on the time of connecting the TTL level output, two-phase input, multiply by 4, duty 50%), 1MHz (Depending on the time of connecting the open-collector output, two-phase input, multiply by 4, duty 50%)

Limit Input Section

Item	Specification
Signal channel	3ch/axis (original point, Forward limit, reserve limit)
Input signal name	ORG : origin input +LIM : positive direction end limit input -LIM : negative direction end limit input
Input logic	Enables selecting the positive/negative logic by using the Software
Input type	Opto-isolated input (corresponding to current sink output)
Response time (Max.)	200 μsec
Input resistor	4.7kΩ
Input ON current	2.0mA or more
Input OFF current	0.16mA or less
External circuit power supply	12V - 24VDC(±10%)

General-purpose Input Section

Item	Specification
Signal channel	7ch/axis
Input signal name	IN1/ALM : alarm input, general-purpose input IN2/INP : positioning completion input, general-purpose input IN3/SD : deceleration (decelerated stop) input, general-purpose input IN4/LTC : counter latch input, general-purpose input IN5/PCS : positioning control start input, general-purpose input IN6 : general-purpose input IN7 : general-purpose input
Input logic	Enables selecting the positive/negative logic by using the Software
Input type	Opto-coupler input (corresponding to current sink output)
Response time (Max.)	200 μsec
Input resistor	4.7kΩ
Input ON current	2.0mA or more
Input OFF current	0.16mA or less
External circuit power supply	12V - 24VDC(±10%)

Pulse Output Section

Item	Specification
Pulse rate	0.3 - 9.8 Mpps
Output signal name	CW : pulse / CW output CCW : direction / CCW output
Output signal system	2 Pulse types (pulse for positive/negative direction) or the common pulse type (pulse signal/directional signal), 90-degree phase difference pulse (lead/lag pulse)
Output form	Un-isolated differential line driver output
Device used	AM26LS31(T.I) or equivalence to it
H-level output voltage	2.5V - 5.25V
L-level output voltage	0V - 0.5V
Output rating current (Max.)	20mA

General-purpose Output Section

Item	Specification
Number of signal channel	3ch/axis
Output signal name	OUT1 : general-purpose output OUT2 : general-purpose output OUT3 : general-purpose output (Each output pin can be switched with the following functions) ALMCLR : alarm clear output ERC : driver differential clear output CP1 : comparator1 output CP2 : comparator2 output
Signal specification	Un-isolated open collector output (current sink type) (Enables selecting the positive/negative logic by using the Software)
Response time (Max.)	10 μsec (when using the loading on the input side 510Ω, +24VDC)
Rated output current (Max.)	100mA per 1ch, 300mA per 1axis
Rated output withstanding voltage (Max.)	50VDC

Support Software

Windows version of motion control driver API-SMC(WDM) [Stored on the bundled CD-ROM driver library API-PAC(W32)]

The API-SMC(WDM) is the Windows version driver library software that provides products in the form of Win32 API functions (DLL). Various sample programs such as Visual Basic and Visual C++, etc and diagnostic program useful for checking operation is provided.

< Operating environment >

OS Windows 7, Vista, XP, Server 2008, Server 2003, 2000

Adaptation language Visual Basic, Visual C++, Visual C#

You can download the updated version from the CONTEC's Web site (<http://www.contec.com/apipac/>). For more details on the supported OS, applicable language and new information, please visit the CONTEC's Web site.

Cable & Connector

Cable (Option)

Shielded Cable With Two 100pin Connector

: PCB100PS-0.5 (0.5m)
: PCB100PS-1.5 (1.5m)
: PCB100PS-3 (3m)
: PCB100PS-5 (5m)

Flat Cable with One 100-Pin Connector

: PCA100P-1.5 (1.5m)
: PCA100P-3 (3m)
: PCA100P-5 (5m)

Accessories

Accessories (Option)

Connection Conversion Board for SMC : CCB-SMC2 *1*2*3
Screw Terminal (M3*100) : EPD-100A *2*3*4

- *1 Distributes 100-pin 0.8-mm pitch connector x 1 to: D-SUB 37 connector x 4, D-SUB-9 connector x 4.
 - *2 A PCB100PS optional cable is required separately.
 - *3 Cables and accessories are required each connector.
 - *4 "Spring-up" type terminal is used to prevent terminal screws from falling off.
- * Check the CONTEC's Web site for more information on these options.

Packing List

Board [SMC-4DL-PCI] ...1
First step guide ...1

- *1 The CD-ROM contains the driver software and User's Guide.

Block Diagram

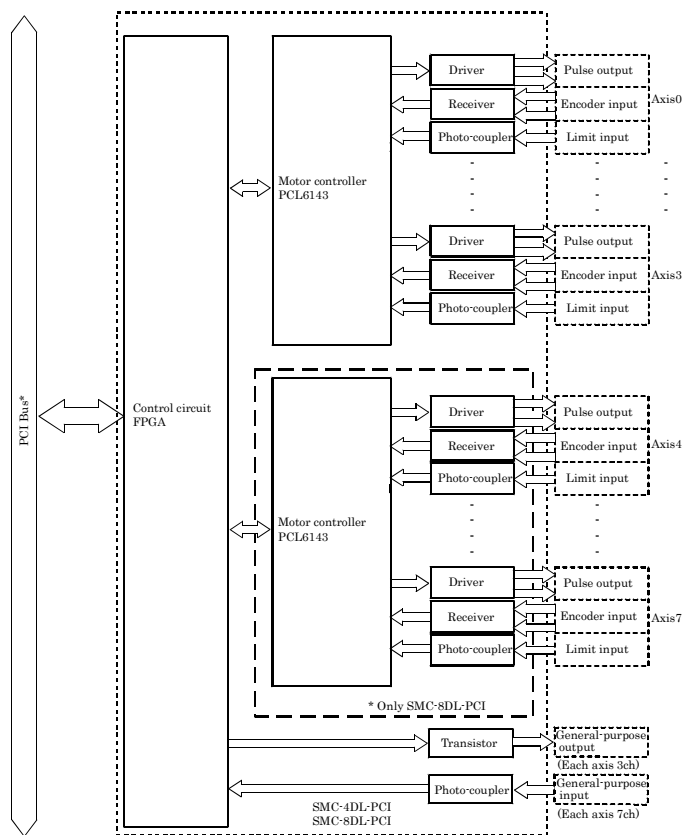

How to connect the connectors

The on-board interface connector (CN1) is used when connecting this product and the external devices.

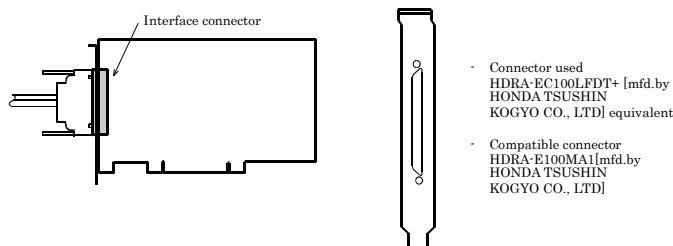

- * Please refer to page 2 for more information on the supported cable and accessories.

Pin Assignments of Interface Connector

CN1			
axis0 : P-COM	100	50	axis2 : P-COM
axis0 : IN1/ALM	99	49	axis2 : IN1/ALM
axis0 : IN2/INP	98	48	axis2 : IN2/INP
axis0 : IN3/SD	97	47	axis2 : IN3/SD
axis0 : IN4/LTC	96	46	axis2 : IN4/LTC
axis0 : IN5/PCS	95	45	axis2 : IN5/PCS
axis0 : IN6	94	44	axis2 : IN6
axis0 : IN7	93	43	axis2 : IN7
axis0 : ORG	92	42	axis2 : ORG
axis0 : +LIM	91	41	axis2 : +LIM
axis0 : -LIM	90	40	axis2 : -LIM
axis1 : P-COM	89	39	axis3 : P-COM
axis1 : IN1/ALM	88	38	axis3 : IN1/ALM
axis1 : IN2/INP	87	37	axis3 : IN2/INP
axis1 : IN3/SD	86	36	axis3 : IN3/SD
axis1 : IN4/LTC	85	35	axis3 : IN4/LTC
axis1 : IN5/PCS	84	34	axis3 : IN5/PCS
axis1 : IN6	83	33	axis3 : IN6
axis1 : IN7	82	32	axis3 : IN7
axis1 : ORG	81	31	axis3 : ORG
axis1 : +LIM	80	30	axis3 : +LIM
axis1 : -LIM	79	29	axis3 : -LIM
axis0 : A+	78	28	axis2 : A+
axis0 : A-	77	27	axis2 : A-
axis0 : B+	76	26	axis2 : B+
axis0 : B-	75	25	axis2 : B-
axis0 : Z+	74	24	axis2 : Z+
axis0 : Z-	73	23	axis2 : Z-
axis1 : A+	72	22	axis3 : A+
axis1 : A-	71	21	axis3 : A-
axis1 : B+	70	20	axis3 : B+
axis1 : B-	69	19	axis3 : B-
axis1 : Z+	68	18	axis3 : Z+
axis1 : Z-	67	17	axis3 : Z-
axis0 : OUT3	66	16	axis2 : OUT3
axis0 : OUT2	65	15	axis2 : OUT2
axis0 : OUT1	64	14	axis2 : OUT1
axis0 : DIR+/CCW+	63	13	axis2 : DIR+/CCW+
axis0 : DIR-/CCW-	62	12	axis2 : DIR-/CCW-
axis0 : OUT+/CW+	61	11	axis2 : OUT+/CW+
axis0 : OUT-/CW-	60	10	axis2 : OUT-/CW-
GND	59	9	GND
axis1 : OUT3	58	8	axis3 : OUT3
axis1 : OUT2	57	7	axis3 : OUT2
axis1 : OUT1	56	6	axis3 : OUT1
axis1 : DIR+/CCW+	55	5	axis3 : DIR+/CCW+
axis1 : DIR-/CCW-	54	4	axis3 : DIR-/CCW-
axis1 : OUT+/CW+	53	3	axis3 : OUT+/CW+
axis1 : OUT-/CW-	52	2	axis3 : OUT-/CW-
GND	51	1	GND

- * Axis0 - Axis3 of this manual corresponds to Axis No.1 - Axis No.4 in API-SMC(WDM).

P-COM	Plus common	B+	Encoder phase B input+
IN1/ALM	General-purpose input1/Alarm input	B-	Encoder phase B input-
IN2/INP	General-purpose input2/Positionig input	Z+	Encoder phase Z input+
IN3/SD	General-purpose input3/Slow down input	Z-	Encoder phase Z input-
IN4/LTC	General-purpose input4/counter latch input	OUT1	General-purpose output1
IN5/PCS	General-purpose input5/positioning operation start input	OUT2	General-purpose output2
IN6	General-purpose input6	OUT3	General-purpose output3
IN7	General-purpose input7	DIR+/CCW+	Direction/CCW output+
ORG	Origin input	DIR-/CCW-	Direction/CCW output-
+LIM	Positive-direction limit	OUT+/CW+	Pulse/CW output+
-LIM	Negative-direction limit	OUT-/CW-	Pulse/CW output-
A+	Encoder phase A input+	GND	Power ground input (common to internal GND)
A-	Encoder phase A input-		

Connecting Output Signals

Pulse output circuit (CW, CCW)

Pulse output circuit on this product is illustrated below. The signal output is a differential line-driver output.

Connection with the differential input

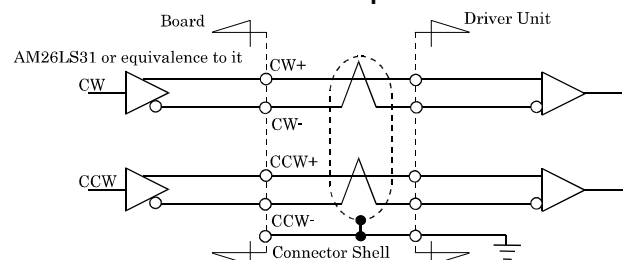

CAUTION

Please use the twisted-pair cable that does the shield processing as a noise measures when connecting it with the differential input.

Connection with the opto-coupler input (When the driver unit guarantees the connection with the differential output)

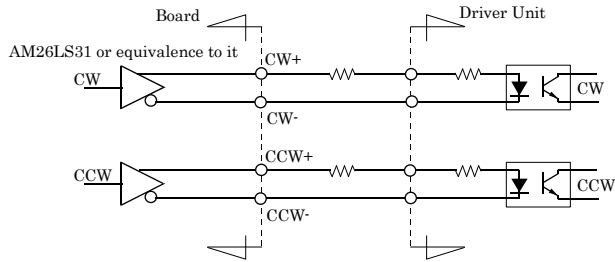

Connection with the opto-coupler input

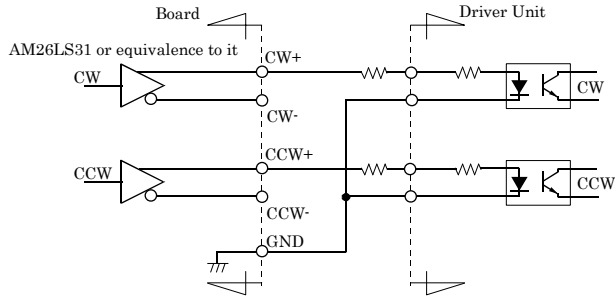

Connection with TTL level input

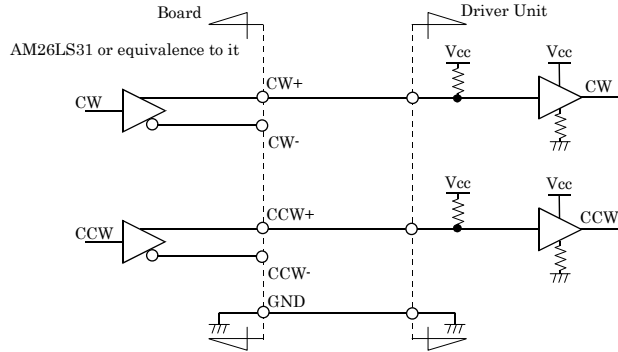

CAUTION

The pulse output part of this product outputs the voltage by 2.5V or more at the High level output, and outputs the voltage of 0.5V or less at the Low level output. When connecting with the photo-coupler input or the TTL level input, please connect it after confirming the specification in the pulse input part of the driver unit operates by the above-mentioned voltage. In addition, please insert a current-limiting resistor according to the allowable current and drive current of the connected input circuit.

To prevent the circuit from malfunctioning due to noise, wire it as far away from other signal lines and noise sources as possible.

Control signal/general-purpose signal output circuit (OUT1 - OUT3, ERC, CP1, CP2)

Output circuit of each output signal on this product is illustrated below. The signal output is an open-collector output. A ground wire must therefore be connected for driving.

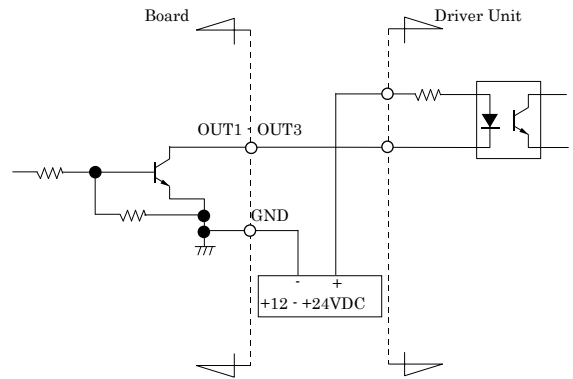

Connecting Input Signals

Encoder input circuit

Encoder input circuit on this product is illustrated below. The signal input is a differential input capable of connecting a line driver output, TTL level output and open-collector output.

Connection with the differential output

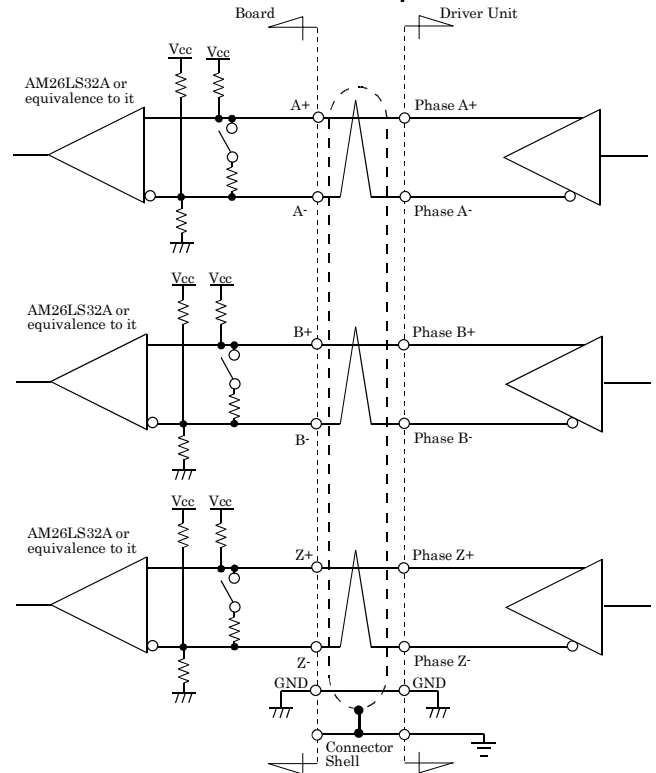

CAUTION

Please use the twisted-pair cable that does the shield processing as a noise measures when connecting it with the differential output.

Restrict the use of cables to 10m for the line driver output.

Connection with the TTL level output

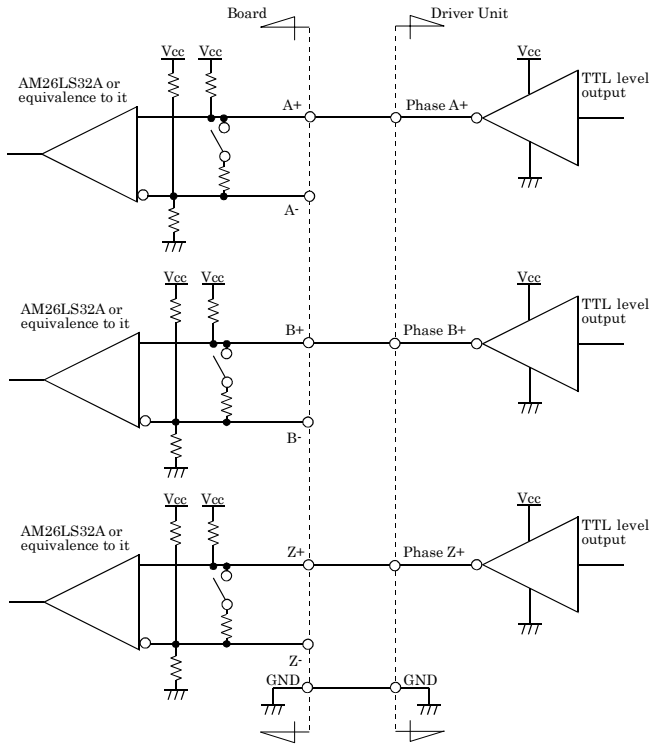

⚠ CAUTION

When connecting TTL level output signals, please do not insert a terminating resistor with reference to "Setting the Terminating Resistor in chapter 2". When inserted with a terminating resistor (factory setting), this product may malfunction, overheat, or causes a failure.

Restrict the use of cables to 1.5m for the TTL level output.

To prevent the circuit from malfunctioning due to noise, wire it as far away from other signal lines and noise sources as possible.

Connection with the open-collector output

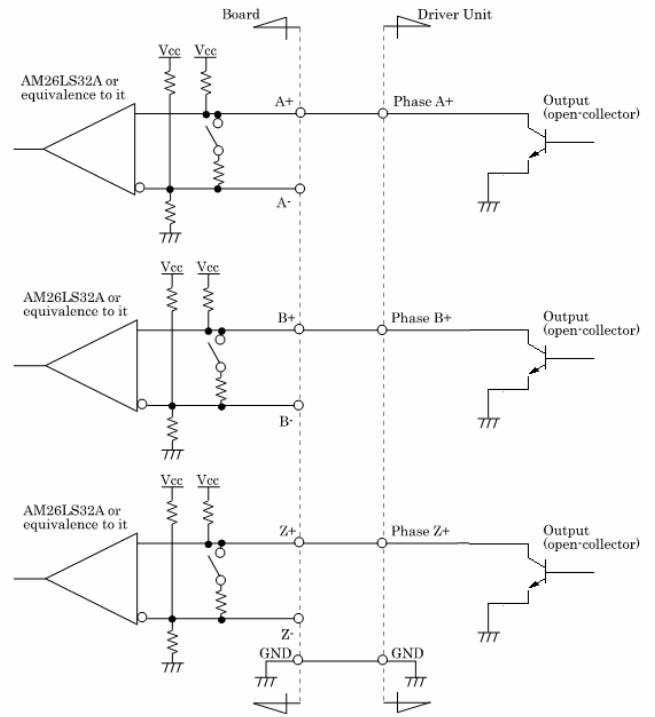

⚠ CAUTION

When connecting open-collector output signals, please do not insert a terminating resistor with reference to "Setting the Terminating Resistor in chapter 2". When inserted with a terminating resistor (factory setting), this product may malfunction, overheat, or causes a failure.

Restrict the use of cables to 3m for the open-collector output.

To prevent the circuit from malfunctioning due to noise, wire it as far away from other signal lines and noise sources as possible.

Limit input/general-purpose input/control input circuit (IN1 - IN7, +LIM, -LIM, ORG)

The limit input/general-purpose input/control input circuit on this board is illustrated below.

The signal input is an opto-isolated, current driven input (sink type). To drive the limit input/general-purpose input/control input block, therefore, an external power supply is required at +12 - +24 V

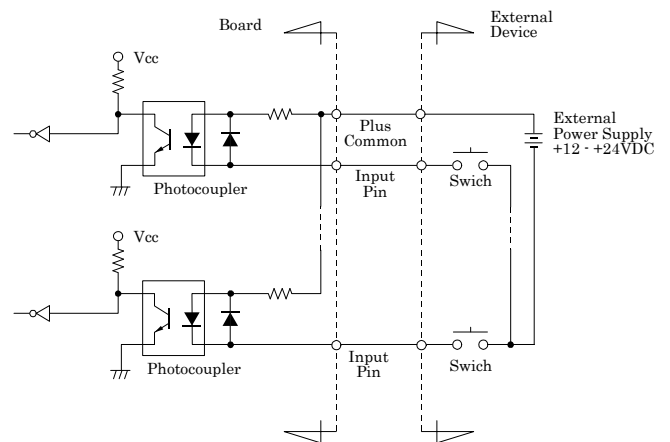

* Input pin is IN1 - IN7, +LIM, -LIM, ORG.

Connection Examples

Given below are practical examples of connection of this product that outputs pulses by the independent pulsing method to motor drivers. These examples show the connections through axis0 (Axis No.1 in API-SMC(WDM)).

Example of Connection to driver unit (Σ II Series) for Servo motor

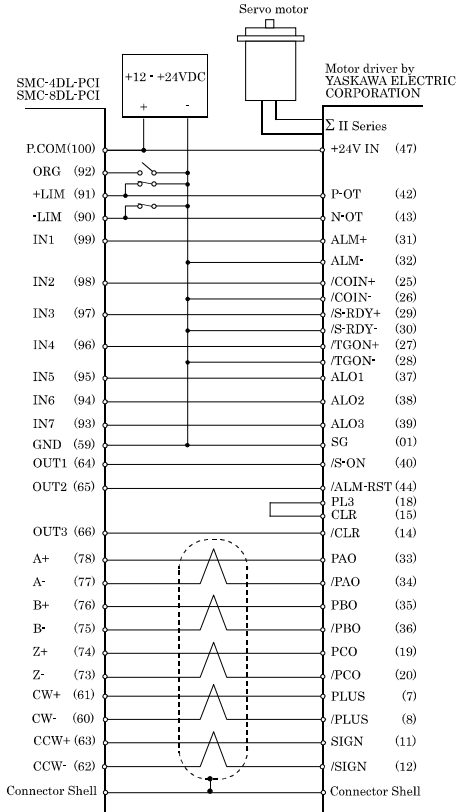

* Please connect the Shield Line of cable with the Connector Shell.

Motion control system configuration

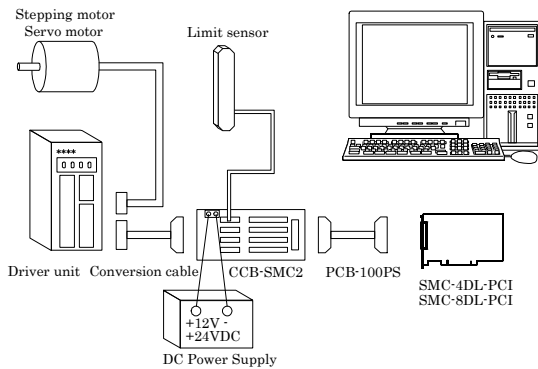

Component features

Item	Description
SMC-4DL-PCI (Main board)	When installed on the PC, this board generates pulses required for position control.
PCB-100PS (Option)	This cable connects the board to the CCB-SMC2.
CCB-SMC2 (Option)	This screw terminal is used to efficiently connect the devices (the board, driver unit, DC power supply, limit sensor) required for position control. The screw terminal can connect a four-axes motion control system alone.
Conversion cable (User)	The shape of the control connector of each driver unit is largely different depending on the manufacturer and type. A conversion cable must be prepared to connect each driver unit to the CCB-SMC2.
Driver unit (Motor maker)	Motor and driver unit to be subject to motion control. Available in various types by motor capacity, power-supply voltage, and motor shape. Select the ones that best fit your needs.
Limit sensor (Switch maker)	This sensor is installed at the forward/backward limit and origin detection positions. When a table is used in the system, the sensor is bundled with the table. For a self-made system, use commercially available switches.
DC Power supply (Power supply maker)	Power supply to the CCB-SMC2. Use a 12 - 24-VDC power supply.