

# NETernity™ GBX460

## Rugged 6U OpenVPX Fully Managed Layer 2/3 10 GigE Switch Module

### Features

- 6U OpenVPX Compliant: (VITA 65.0)
- VITA 48 (REDI)
- VITA 46.0-2007 (VPX Baseline Standard)
- Switch Profile: SLT6-SWH-16U20F-10.4.2
  - Data Plane: 20 x 10GE Ports
  - Control Plane: 16 x 1 GbE Ports
- Optional Profile: SLT6-SWH-24F-10.4.3
  - Data Plane: 24 x 10GE Ports
- Non-Blocking
- Front I/O: Up to four 10GigE Fiber Ports available for slot profile SLT6-SWH-16U20F-10.4.2
- Full wire-speed 10GE Performance
- Ruggedization Build Levels:
  - Level 1, 2 & 3 Air Cooled
  - Level 4 & 5 Conduction Cooled
- RoHS 2002/95/EC Compliant
- Based on high-performance Low Latency, Ethernet switch fabric from Fulcrum Microsystems
- IEEE 802.3-2005
- Option for Unmanaged operation
- Hardware enabled IPv6 and IPv4 support
- OpenWare Switch Management environment
- Multi-cast Support: IGMP Snooping Querier and MLD Snooping Querier
- Allows up to 4096 VLANs
- L-3 Protocol support including OSPF, RIP and VRRP

Neternity™ GBX460 is the world's first rugged 6U OpenVPX Fully Managed Layer 2/3 10Gigabit Ethernet switch module supporting low latency, high throughput interprocessor communication (IPC) aimed at deployed defense and aerospace applications.

GBX460 delivers full wire-speed 10Gigabit Ethernet switching that can be fully managed via our OpenWare software. Proven, high performance architecture and a multilayer switching fabric provides a rich feature set, broad functionality, scalability, and product life longevity. Based on a PowerPC management processor and a leading high performance switch fabric, the GBX460 has integrated Layer-2/3 switching capabilities including support for IPv6 as well as the ability to support higher Layer 4-7 functionality when required.

IPv6 brings improved security, reliability and flexibility, enhanced support for mobile computing devices, and larger address space for global reach and scalability to applications. In the near future, support for IPv6 will be required for Military and Defense customers, and because this switch also supports IPv4 it offers a path forward which protects existing investments.

GBX460 delivers any node to any node connectivity between multiple computer nodes to support the very latest (HPC) Intel and NVIDIA GPGPU high performance

computing cluster architectures. Typical applications include sensor and image processing for a range of intelligence, surveillance and reconnaissance (ISR) platforms including radar and communications processing.

Designed to support GE-IPs market leading, rugged 6U OpenVPX single board computers (SBCs) and GPGPU processors, the GBX460 harnesses the speed and flexibility of the very latest 10GigE switch fabric from Fulcrum Microsystems. This innovative solution supports non-blocking, low latency data transfers across a multiprocessor cluster at up to full wire speed enabling new levels of performance for the most demanding ISR applications.

GE-IP's latest 6U OpenVPX products are available in air and conduction cooled variants providing a clear choice for size, weight and power (SWaP) sensitive HPC applications. In addition, it has the flexibility to support high speed sensor I/O over 10GigE and system scaling from one to many compute nodes on airborne, ground vehicle and naval platforms to meet the most demanding mission profiles.

The extremely fast boot time for the GBX460 enables it to meet the needs of customer applications that require their network to be passing traffic in the shortest period of time after power-on.



# NETernity™ GBX460 Rugged 6U OpenVPX Fully Managed Layer 2/3 10 GigE Switch Module

NETernity GBX460 is a High Performance Layer 2/3+ Ethernet embedded switch with extensive management capabilities and provides hardware speed switching of L-2 and L-3 frames including IPv6 switching and routing. Optionally, the twenty 10GigE and sixteen 1GigE version of the GBX460 can support up to four 10Gigabit Ethernet Fiber connections on the front panel. Per the OpenVPX standard, the 10 Gigabit Ethernet connections support the data plane and the sixteen 1Gigabit Ethernet connections support the control plane. The GBX460 is also available in a configuration supporting twenty four 10Gigabit Ethernet ports routed to the VPX Switch Fabric ports.

Designed to meet the needs of a wide range of challenging applications in military systems, the 6U VPX form factor GBX460 facilitates communications at high speed within the chassis or for external networks via its 10Gigabit Ethernet ports. The GBX460's high speed network capability is ideal for applications such as situational awareness, imaging, and sensor data.

## Switch Fabric and OpenWare Protocol Features

- Supports both Layer-2 (L2) and Layer 3 (L3) packet switching. Packets are categorized by the MAC addresses for L2 switching and by IP addresses for L3 switching.
- QoS prioritization (IEEE 802.1D) permits classifying packet priorities which is beneficial in delay-sensitive applications.
- Packet filtering to prevent forwarding of certain packets; filtering capabilities are available in Layers 2 - 7.
- Link aggregation (IEEE 802.3ad) links a group of physical ports creating a single logical port to provide higher bandwidth and increase redundancy between switches. The fabric is capable of full wire speed switching, allowing a maximum aggregate throughput that is the sum of all aggregated ports.
- Virtual LANs (VLANs) (IEEE 802.1Q) defines a forwarding (switching) domain; supports up to 4096 VLANs.
- Multiple Spanning Tree Protocol (MSTP) (IEEE 802.1Q) enables automatic and rapid determination of an optimal loop-free topology from an arbitrary network of enabled switches with duplicate and redundant connections; supports rapid reconfiguration in the event of a link or switch failure; backward compatible with RSTP and STP.

- Broadcast storm control screens excessive traffic and controls the rate limit for each port and prevents flooding in the network.
- IGMP snooping permits the switch to monitor IGMP interactions between hosts and routers and to adjust its forwarding tables accordingly resulting in more efficient bandwidth use.
- Port mirroring eases debug and packet pattern study. This is a method to observe on one port traffic that is flowing on another port.

## L-3 IP Routing Protocols

- OSPF (Open Shortest Path First), a flexible link state protocol, tests the state of links and transmits that information throughout the system to establish the shortest path to the destination. This protocol also load balances by distributing traffic equally among routes. Messages may also be routed based on the type of service so that critical messages can transverse the most reliable routes.
- RIP (Routing Information Protocol), an easy-to-implement, dynamic routing protocol, allows routers to exchange information for computing routes through networks. Routing tables are used to store destination and metric pairs.
- VRRP (Virtual Router Redundancy Protocol) eliminates single points of failure on a network. Using an election protocol to provide failover for forwarding packets, VRRP provides a higher availability default path.

# NETernity™ GBX460 Rugged 6U OpenVPX Fully Managed Layer 2/3 10 GigE Switch Module

## OpenWare Switch Management Environment

OpenWare™ is available exclusively on selected Neternity fully-managed Layer-2/3 Ethernet switches. Comprehensive and powerful, this switch management environment provides integrated management services including configuration, monitoring, switching control, addressing, routing and all supported protocols. Configuration and monitoring functions are accessible from a serial console or via a network. Supported access methods include Telnet, SSH and SNMP.

### OpenWare features:

- IPv6 support for improved security, reliability and flexibility, enhanced support for mobile computing devices, and larger address space for global reach and scalability. IPv4 is also supported offering a path forward which protects existing investments.
- Easy deployment and management that results from the wide range of protocols supported. These protocols are defined by RFCs, and cover a range of operations: Switch, VLANs, Aggregation, Multicast, Filtering, Routing, QoS, and Management, Neternity switches with OpenWare offer broad functionality and support communications within the chassis as well as supporting the network outside of the chassis.
- MSTP, the latest version of the Spanning Tree protocol, allows use of the latest technology to create efficient, loop-free networks by combining multiple VLANs. In the event of link or switch failure, the network can be rapidly reconfigured minimizing down time. MSTP is backward compatible with RSTP and STP.
- Highly efficient bandwidth utilization. Multicast with IGMP Snooping Querier and MLD Snooping Querier for IPv6 operation ensures that frames are only forwarded on those ports having nodes that have joined the group.
- OpenWare makes use of Linux® based software to allow faster implementation and easy updates to firmware as part of standard releases or when customization is required. Customizations may be leveraged across all Neternity/OpenWare platforms. Standard Linux commands may be used as well as open source protocol and routing capabilities.
- OpenWare allows for a number of ways to manage the switch via serial console, Telnet or Web Interface.
- Using a combination of open source protocol software and OpenWare allows us in certain instances to provide full software source to customers. Additionally, full control over the software environments permits customization for specific requirements such as customer-specific handling of failover conditions.

## Why choose GE Intelligent Platforms Neternity Ethernet Switches?

GE Intelligent Platforms has a wealth of expertise in Military, Commercial and Telecommunications markets. This makes us unique in the embedded computing industry – we understand application requirements and we know communication protocols.

Our line of Neternity Ethernet Switches is unmatched. Not only is our product selection extensive, but the switches themselves provide maximum flexibility, performance, and density. Neternity Ethernet Switches are available in a variety of form factors, interfaces, and levels of ruggedness, port configurations, media support, and types of management.

Fully Managed switches are Layer 2/3+ switches with control and monitoring capabilities via local or remote access. Layer 2 managed switches are switches with control and monitoring capabilities, but with the management limited to layer 2 capabilities. These are also accessed locally or remotely. Unmanaged switches are Layer-2 switches with no operator interfacing and are designed for quick deployment in simpler applications.

Call GE Intelligent Platforms knowledgeable sales team for help in selecting the switch that best meets your applications requirements.

# NETernity™ GBX460 Rugged 6U OpenVPX Fully Managed Layer 2/3 10 GigE Switch Module

## Specifications

### Physical Interface

- All 10 Gigabit and 1 Gigabit Ethernet ports are routed to the VPX backplane along with the Ethernet management port and serial console.
- 10 Gigabit Ethernet ports support 10GBASE-CX4 or 10GBASE-KX-4
- 1 Gigabit Ethernet ports support - 1000BaseCX

### Form Factor

- 6U OpenVPX™ air, spray and conduction cooled builds
- 6U VITA48 REDI for 2LM
- Weight: TBD

### OpenVPX™

- SLT6-SWH-16U20F-10.4.2
- SLT6-SWH-24F-10.4.3

### Power Requirements (Maximum)

- TBD

### MTBF

- TBD

### Environmental

- Ruggedization Level 1
  - Operating Temperature: 0 to +55C
  - Storage Temperature: -50 to +100C
  - Vibration: 0.002g/Hz from 10 to 2000Hz random and 2g sinusoidal from 5 to 500Hz
  - Shock: 20g peak sawtooth, 11ms duration
  - Humidity: Up to 95%RH
- Ruggedization Level 2
  - Operating Temperature: -20 to +65C
  - Storage Temperature: -50 to +100C
  - Vibration: 0.002g/Hz from 10 to 2000Hz random and 2g sinusoidal from 5 to 500Hz
  - Shock: 20g peak sawtooth, 11ms duration
  - Humidity: Up to 95%RH
- Ruggedization Level 3
  - Operating Temperature: -40 to +75C
  - Storage Temperature: -50 to +100C
  - Vibration: 0.004g/Hz 20 to 2000Hz with a flat response to 1000Hz. 6dB/octave roo-off from 1000 to 2000Hz
  - Shock: 20g peak sawtooth, 11ms duration
  - Humidity: Up to 95%RH
- Ruggedization Level 4
  - Operating Temperature: -40 to +75C at thermal interface
  - Storage Temperature: -50 to +100C
  - Vibration: Random 0.1g2/HZ from 15 to 2000HZ per MIL-STD-810E Fig 514.4 -8 for high performance aircraft - 12g RMS
  - Shock: 40g peak sawtooth, 11ms duration
  - Humidity: Up to 95%RH
- Ruggedization Level 5
  - Operating Temperature: -40 to +85C at thermal interface
  - Storage Temperature: -50 to +100C
  - Vibration: Random 0.1g2/HZ from 15 to 2000HZ per MIL-STD-810E Fig 514.4 -8 for high performance aircraft - 12g RMS
  - Shock: 40g peak sawtooth, 11ms duration
  - Humidity: Up to 95%RH

## Block Diagram

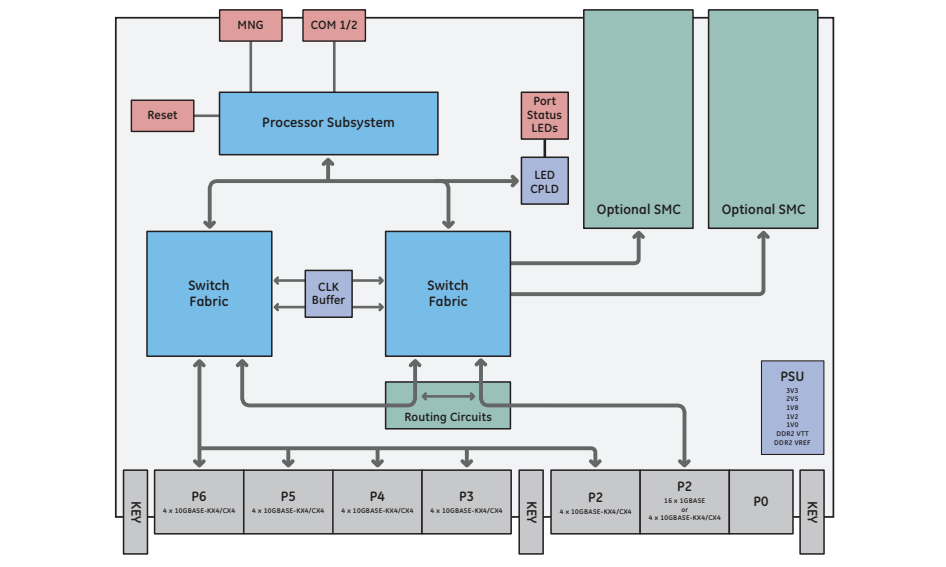

## Ordering Information

### GBX460 - abcdef

Where a is level of ruggedization 1-5 r = 1,2,3,4,5

Where b is 1 for 24 10GigE ports; 2 for 2010GigE + 16 1GigE ports

Where c is number of 10GigE fiber ports: c = 1,2,3 or 4

Where d is 10GigE transceiver type: 0=N/A; 1=SR, 2=LR and 3=ER

Where e is for type of rear I/O standard; 0=10GBase-KX4; 1=10GBase-CX4

Where f is 0=unmanaged or 1=managed

**GBX460RTM-11 6U VPX** Rear Transition Module with ten 10GigE CX-4 connectors

**GBX460RTM1-11 6U VPX** Rear Transition Module with two 10GigE CX-4 connectors and eight 1GigE SFP's (unpopulated)

**POPW-GBX460-01M** OpenWare Maintenance

**POPW-GBX460-01A** OpenWare Maintenance Renewal

## About GE Intelligent Platforms

GE Intelligent Platforms, a General Electric Company (NYSE: GE), is an experienced high-performance technology company and a global provider of hardware, software, services, and expertise in automation and embedded computing. We offer a unique foundation of agile, advanced and ultra-reliable technology that provides customers a sustainable advantage in the industries they serve, including energy, water, consumer packaged goods, government and defense, and telecommunications. GE Intelligent Platforms is a worldwide company headquartered in Charlottesville, VA and is part of GE Home and Business Solutions. For more information, visit [www.ge-ip.com](http://www.ge-ip.com).

## GE Intelligent Platforms Contact Information

Americas: **1 800 433 2682** or **1 434 978 5100**

Global regional phone numbers are listed by location on our web site at [www.ge-ip.com/contact](http://www.ge-ip.com/contact)

[www.ge-ip.com/ethernet-lan](http://www.ge-ip.com/ethernet-lan)

