

Super-mini Signal Conditioners Mini-M Series

CURRENT LOOP SUPPLY

(with square root extractor)

Functions & Features

- Powers a 4 - 20 mA DC current loop
- Square root extraction
- Shortcircuit protection
- Applicable to smart transmitters
- CE marking
- UL approval

Typical Applications

- Various 2-wire transmitters

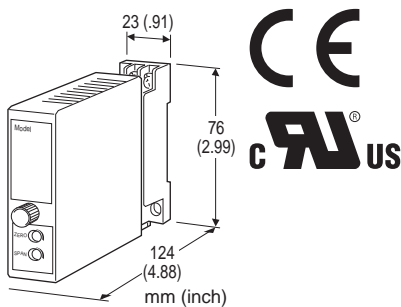

MODEL: M2DNY-24[1]-[2][3]

ORDERING INFORMATION

- Code number: M2DNY-24[1]-[2][3]
- Specify a code from below for each [1] through [3]. (e.g. M2DNY-24A-M2/CE/Q)
- Special output range (For codes Z & 0)
- Specify the specification for option code /Q (e.g. /C01/S01)

SUPPLY OUTPUT

24: 24 V DC

INPUT

Current

4 - 20 mA DC

[1] OUTPUT

Current

- A: 4 - 20 mA DC (Load resistance 750 Ω max.)
- B: 2 - 10 mA DC (Load resistance 1500 Ω max.)
- C: 1 - 5 mA DC (Load resistance 3000 Ω max.)
- D: 0 - 20 mA DC (Load resistance 750 Ω max.)
- E: 0 - 16 mA DC (Load resistance 900 Ω max.)

F: 0 - 10 mA DC (Load resistance 1500 Ω max.)

G: 0 - 1 mA DC (Load resistance 15 kΩ max.)

Z: Specify current (See OUTPUT SPECIFICATIONS)

Voltage

1: 0 - 10 mV DC (Load resistance 10 kΩ min.)

2: 0 - 100 mV DC (Load resistance 100 kΩ min.)

3: 0 - 1 V DC (Load resistance 1000 Ω min.)

4: 0 - 10 V DC (Load resistance 10 kΩ min.)

5: 0 - 5 V DC (Load resistance 5000 Ω min.)

6: 1 - 5 V DC (Load resistance 5000 Ω min.)

0: Specify voltage (See OUTPUT SPECIFICATIONS)

[2] POWER INPUT

AC Power

M: 85 - 264 V AC (Operational voltage range 85 - 264 V, 47 - 66 Hz)

(Select '/N' for 'Standards & Approvals' code.)

M2: 100 - 240 V AC (Operational voltage range 85 - 264 V, 47 - 66 Hz)

(90 - 264 V for UL)

DC Power

R: 24 V DC

(Operational voltage range 24 V ±10 %, ripple 10 %p-p max.)

R2: 11 - 27 V DC

(Operational voltage range 11 - 27 V, ripple 10 %p-p max.)

(Select '/N' for 'Standards & Approvals' code.)

P: 110 V DC

(Operational voltage range 85 - 150 V, ripple 10 %p-p max.)

(110 V ±10 % for UL)

[3] OPTIONS (multiple selections)

STANDARDS & APPROVALS (must be specified)

/N: Without CE or UL

/CE: CE marking

/UL: UL approval (CE marking)

OTHER OPTIONS

blank: none

/Q: Option other than the above (specify the specification)

(UL not available)

SPECIFICATIONS OF OPTION: Q (multiple selections)

COATING (For the detail, refer to M-System's web site.)

/C01: Silicone coating

/C02: Polyurethane coating

/C03: Rubber coating

TERMINAL SCREW MATERIAL

/S01: Stainless steel

GENERAL SPECIFICATIONS

Construction: Plug-in
Connection: M3 screw terminals (torque 0.8 N·m)
Housing material: Flame-resistant resin (black)
Isolation: Input to output to power
Overrange output: 0 to 110 % at 1 - 5 V
Zero adjustment: -5 to +5 % (front)
Span adjustment: 95 to 105 % (front)
Low-end cutout: Approx. 4 - 8 % (output)

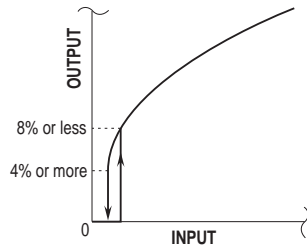

SUPPLY OUTPUT

(across the terminals 1 - 8)
Output voltage: 24 - 28 V DC with no load
 18 V DC min. at 20 mA
Current rating: ≤ 22 mA DC
 • **Shortcircuit Protection**
Current limited: 30 mA max.
Protected time duration: No limit

INPUT SPECIFICATIONS

• **DC Current:** Input resistors incorporated
 Approx. 300 Ω (50 Ω as receiving resistor, 250 Ω across the monitor terminals)

OUTPUT SPECIFICATIONS

• **DC Current:** 0 - 20 mA DC
Minimum span: 1 mA
Offset: Max. 1.5 times span
Load resistance: Output drive 15 V max.
 • **DC Voltage:** 0 - 12 V DC
Minimum span: 10 mV
Offset: Max. 1.5 times span
Load resistance: Output drive 1 mA max.; at ≥ 0.5 V

INSTALLATION

Power Consumption
 • **AC Power input:**
 Approx. 3 VA at 100 V
 Approx. 4 VA at 200 V
 Approx. 5 VA at 264 V
 • **DC Power input:** Approx. 3 W
Operating temperature: -5 to +55°C (23 to 131°F)

Operating humidity: 30 to 90 %RH (non-condensing)
Mounting: Surface or DIN rail
Weight: 150 g (0.33 lbs)

PERFORMANCE in percentage of span

Accuracy: ±0.2 % (input 1 - 100 %)
Temp. coefficient: ±0.015 %/°C (±0.008 %/°F)
Response time: ≤ 0.5 sec. (0 - 90 %)
Line voltage effect
 • **Supply output:** ±3 % over voltage range
 • **Output signal:** ±0.1 % over voltage range
Insulation resistance: ≥ 100 MΩ with 500 V DC
Dielectric strength: 2000 V AC @1 minute (input to output to power to ground)

STANDARDS & APPROVALS

CE conformity:
 EMC Directive (2004/108/EC)
 EN 61000-6-4 (EMI)
 EN 61000-6-2 (EMS)
 Low Voltage Directive (2006/95/EC)
 EN 61010-1
 Installation Category II
 Pollution Degree 2
 Max. operating voltage 300 V
 Input or output to power: Reinforced insulation
 Input to output: Basic insulation

Approval:
 UL/C-UL nonincendive Class I, Division 2,
 Groups A, B, C, and D hazardous locations
 (ANSI/ISA-12.12.01, CAN/CSA-C22.2 No.213)
 UL/C-UL general safety requirements
 (UL 61010B-1, CAN/CSA-C22.2 No.1010-1)

DIMENSIONS unit: mm (inch)

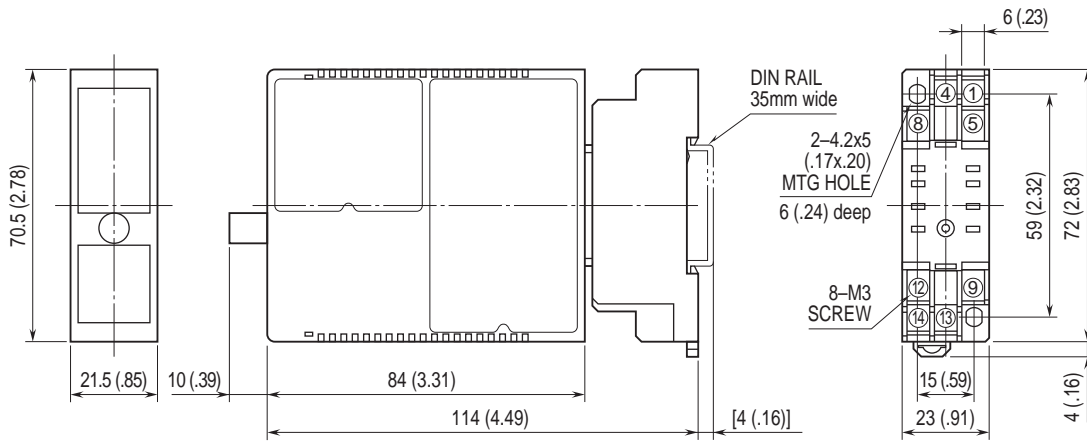

• When mounting, no extra space is needed between units.

SCHEMATIC CIRCUITRY & CONNECTION DIAGRAM

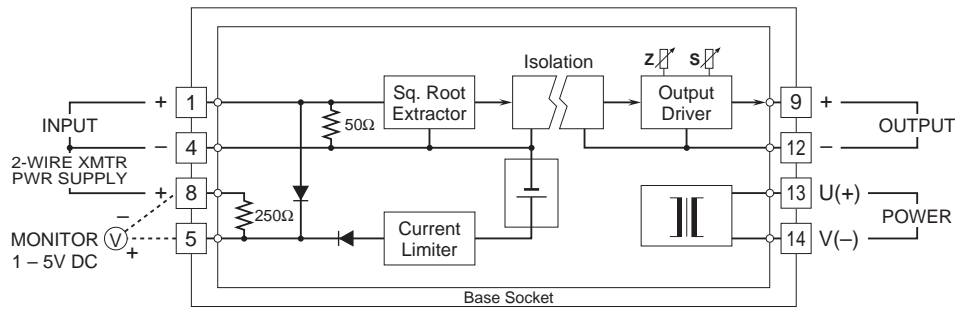

■ When Used as DC Supply

2-WIRE
TRANSMITTER

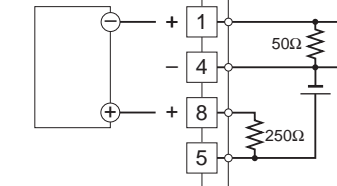

■ When Used as Square Root Extractor

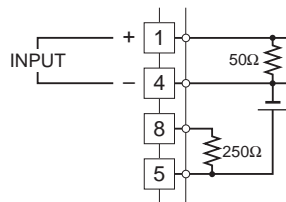

Specifications are subject to change without notice.