

### E-trAC® XFC SERIES ADDED FEATURES

This manual documents the features available with the release of software revision 13.1 / 13.3 or greater. The software revision number can be viewed in parameter 02-RVLVL in Level 2 programming. Please note the following changes from previous manuals and other software revisions:



## *XFC Series Micro-Inverter*

XFC1000 Series - 1/2 & 1 HP

XFC2000 Series - 1/2 through 5 HP

XFC4000 Series - 1 through 5 HP

Installation, Operation and  
Maintenance Instructions



**TB WOOD'S INCORPORATED**  
Chambersburg, Pennsylvania

**E-TRAC® XFC SERIES MICRO-INVERTER**  
PARAMETER CODE SUMMARY



PARAMETER	DESCRIPTION	RANGE (FACTORY SETTING)	PAGE	CUSTOMER SETTING
02-RVLVL	Software Revision	Note 1	34	
03-IRAT	Inverter Rated Current	Note 1	34	
07-FLT3	Last Fault	Note 1	34	
08-FLT2	2nd Fault	Note 1	34	
09-FLT1	1st Fault	Note 1	34	
12-FOUT	Motor Output Frequency	0-400 Hz	34	
13-VOUT	Motor Output Voltage	0-100% of line voltage	35	
14-IOUT	Motor Output Current	0-60	35	
15-LOAD	Drive Load	0-200% of 03-IRAT	35	
16-TORQ	Load Torque	0-200%	35	
17-TEMP	Drive Temperature	0-100°C	35	
21-MODE	Input Mode	00-11 Note 2	36	
24-FSEL	Speed Setpoint Selector	0-3 (0)	37	
31-FMIN	Minimum Frequency	0-400 Hz (0)	37	
32-FMAX	Maximum Frequency	20-400 Hz (60)	37	
33-F2	Preset Frequency #2	0-400 Hz (5)	37	
34-F3	Preset Frequency #3	0-400 Hz (20)	37	
35-F4	Preset Frequency #4	0-400 Hz (40)	37	
36-F5	Preset Frequency #5	0-400 Hz (60)	37	
37-F6	Preset Frequency #6	0-400 Hz (0)	37	
38-F7	Preset Frequency #7	0-400 Hz (0)	37	
39-FTL	Minimum Frequency in Torque Limit	0-400 Hz (10)	38	
41-RSEL	Ramp Selector	0-7 (0)	38	
42-ACC1	Acceleration Time #1	0.1-600 Sec (3)	39	
43-DEC1	Deceleration Time #1	0.1-600 Sec (3)	39	
44-ACC2	Acceleration Time #2	0.1-600 Sec (1)	39	
45-DEC2	Deceleration Time #2	0.1-600 Sec (1)	39	
46-DECTL	Deceleration Time in Torque Limit	0.1-30 Sec (1)	39	

PARAMETER	DESCRIPTION	RANGE (FACTORY SETTING)	PAGE	CUSTOMER SETTING
47-DCBRK	DC Brake Time	0-5 Sec (0.2)	40	
48-DCVLT	DC Brake Voltage	0-15%	40	
51-VSEL	V/Hz Characteristic Selector	0-5 (0)	41	
52-BOOST	Torque Boost	0-25%	42	
53-FKNEE	V/Hz Knee Frequency	26-960 Hz (60)	42	
59-MVOLT	Rated Motor Voltage	185-240 370-480	42	
61-LTLF	Preset Load Torque Limit FWD	30-150% (150)	42	
62-LTLR	Preset Load Torque Limit REV	30-150% (150)	42	
63-RTL F	Preset Regenerative Torque Limit FWD	30-110% (80)	42	
64-RTL R	Preset Regenerative Torque Limit REV	30-110% (80)	42	
65-SLIP	Slip Compensation	0-12% (0)	43	
66-STAB	Current Stability	0-1 (1)	43	
67-TOL	Timed Overload Trip Point	0-100% (0)	43	
68-NRST	Trip Restart Number	0-8 (0)	44	
69-DRST	Restart Time Delay	0-60 Sec (0)	45	
70-MCAL	Analog Meter Output Calibration	0-255 (Set for 10 VDC)	45	
71-METER	Analog Meter Output Selector	0-3 (1)	45	
75-STR	Auxiliary Relay Output	0-10 (2)	46	
77-MOL	Motor Overload Input	0-3 (0)	47	
81-PRGNO	Special Program Number	0-9999 (0)	48	
82-START	Start Options	0-7 (0)	48	
84-DISP	Display Option Setting	0-3000 (0)	50	
87-ACODE	Security Access Code	0-999 (0)	50	

NOTE: 1. See Section 4.2 for definitions of data  
2. Models with keypad:  
Models without keypad:  
3. Level 1 Parameters shown shaded.

Data Code = 0  
Data Code = 3

## TABLE OF CONTENTS

<b>Section 1 - General Information</b>	<b>Page</b>
1.1 Preface .....	1
1.2 Inspection .....	1
1.3 Model Identification Number .....	2
1.4 Power Specifications .....	3
1.5 General Drive Specifications .....	4
<b>Section 2 - Installation and Enclosure Information</b>	
2.1 General Rules for Installation .....	6
2.2 Explosion Proof Applications .....	7
2.3 Line Starting .....	7
2.4 Dimensional Data .....	8
2.5 Input AC Line Requirements .....	12
2.5A Single Phase Operation.....	13
2.6 AC Line Protection.....	14
2.7 Wiring Practices.....	15
2.8 Reducing Current Surges .....	16
2.9 Function and Use of Terminals.....	18
2.10 J22 Option Connector.....	20
2.11 Input Terminal Usage .....	21
2.12 J19 Configuration .....	23
<b>Section 3 - Getting Started</b>	
3.1 General Information .....	24
3.2 Digital Keypad .....	25
3.3 Keypad Operation.....	25
3.4 Operation Mode.....	26
3.5 Program Mode.....	27
3.6 Status Indicator.....	28
3.7 Description of Displays .....	28
3.8 Parameter Access .....	30
3.9 Display Scroll Rate .....	30
3.10 Restoring Factory Settings .....	30
3.11 Help .....	30
3.12 Quick Start.....	31

## TABLE OF CONTENTS

<b>Section 4 - Parameter Descriptions and Programming</b>	
4.1 Programming .....	33
4.2 Parameter Descriptions .....	34
<b>Section 5 - Connection Diagrams</b>	
5.1 AC Line and Motor Connections.....	51
5.2 2-Wire Run/Stop Connections .....	52
5.3 3-Wire Run/Stop Connections .....	52
5.4 Analog Speed Input Connections .....	53
5.5 MOL Terminal Connections.....	53
5.6 Optional Connections .....	54
<b>Section 6 - Troubleshooting</b>	
6.1 Special Indications.....	55
6.2 Fault Trip Indications .....	56
6.3 Resetting a Fault .....	56
6.4 Fault Codes .....	57
6.5 Troubleshooting.....	59
<b>Section 7 - Appendix</b>	
7.1 Warranty Statement.....	60
7.2 E-trAC® XFC Series Options.....	61

## SECTION 1 GENERAL INFORMATION

### 1.1 Preface

This manual contains the specifications, installation instructions, description of operation, and trouble-shooting procedures for the E-trAC® XFC1000, XFC2000 and XFC4000 micro-inverter. Before installing the drive, read this manual carefully to ensure correct installation and maximum performance.

### 1.2 Inspection

- A. Upon receipt, unpack and carefully inspect for any damage sustained in transit (depression in the enclosure, damage to parts, missing parts). If damage is apparent, the shipping agent should be notified.
- B. Remove the terminal access cover (See Section 2.9C), if supplied, and inspect for any apparent damage or foreign objects.
- C. Read the technical data label and ensure that the correct horsepower and input voltage for the application has been purchased.
- D. If the inverter is to be stored for a long period of time, re-pack and store in a clean, dry place, free from direct sunlight or corrosive fumes, and in a location where the ambient temperature will not be less than -20°C (-4°F) nor more than +60°C (+140°F).

### 1.3 Model Identification Number

A systematic numbering system is used to define all E-trAC® models by torque output, input voltage rating horsepower rating and enclosure type. The model number appears on the shipping carton label and the technical data label of the drive. (See Table 1.1 below).

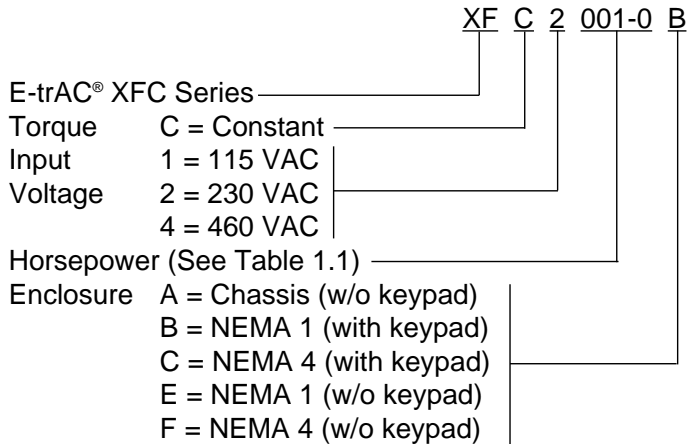

This model number describes a constant torque, E-trAC® XFC series micro-inverter in a NEMA 1 enclosure with keypad, rated 1.0HP, with input voltage of 230 VAC.

HP CODE	HP	115 VAC	230 VAC	460 VAC
000-5	1/2	X	X	
001-0	1.0	X	X	X
002-0	2.0		X	X
003-0	3.0		X	X
005-0	5.0		X	X

TABLE 1.1

### 1.4 Power Specifications

Model - XFC	Input Phases	1000-5	1001-0	2000-5	2001-0	2002-0	2003-0	2005-0	4001-0	4002-0	4003-0	4005-0 (2)	4005-0 (3)
Horsepower	3	---	---	0.5	1.0	2.0	3.0	5.0	1.0	2.0	3.0	5.0	5.0
Kilowatt (kW)	3	---	---	0.37	0.75	1.5	2.2	3.7	0.75	1.5	2.2	3.7	3.7
Horsepower	1	0.5	1.0	0.33	0.75	1.5	2.0	3.0	---	---	---	---	---
Kilowatt (kW)	1	0.37	0.75	0.25	0.55	1.1	1.5	2.2	---	---	---	---	---
Output Voltage (Three Phase)		3.5 - 230VAC		3.5 - 230VAC		3.5 - 230VAC		7.0 - 460 VAC		7.0 - 460 VAC		7.0-400 VAC	7.0-460 VAC
Maximum Continuous Output Amps	3	---	---	2.2 (1)	4.0 (1)	7.5 (1)	10.6 (1)	16.7 (1)	2.2 (1)	4.1 (1)	6.1 (1)	9.9 (1)	8.4
	1	2.2 (1)	4.0 (1)	1.8	3.1	5.7	7.5	10.5	---	---	---	---	---
Input Voltage (±10%)		115 VAC		208-230 VAC		400-460 VAC		400-460 VAC		400-460 VAC		400 VAC 460 VAC	
Input Amps	3	---	---	1.9	3.8	7.5	10.4	17.6	2.3	5.1	6.2	10.8	10.8
	1	4.5	8.9	2.2	4.4	8.1	14.5	21.0	---	---	---	---	---

Note 1. Value = 1.1 x 03-IRAT (See Section 4.2)

Note 2. Models XFC4005-0A, B, E

Note 3. Models XFC4005-0C, F

TABLE 1.2

### 1.5 General Drive Specifications

<b>Overload Capacity</b>	150% for 60 Seconds
<b>Starting Torque</b>	Greater than 100%
<b>Input Frequency (± 10%)</b>	50/60 Hz
<b>Phase Imbalance (3Ø only)</b>	±2%
<b>Operating Temperature</b>	0°C to +40°C (NEMA 1/NEMA 4 models) 0°C to +50°C (Chassis model)
<b>Humidity</b>	90% RH or less, non-condensing
<b>Vibration</b>	0.6 G Maximum
<b>Elevation</b>	1000 Meters (3,300 Feet) w/o derating
<b>Frequency Range</b>	0.1-400 Hz programmable in 0.05 Hz increments. (0.1 Hz above 99.95 Hz)
<b>Control System</b>	Voltage Vector PWM
<b>Frequency Command Selections</b>	0-5 VDC, 0-10 VDC, 0-20 mA, 4-20 mA, direct or inverted; Digital Keypad; Program Memory Unit; Remote Keypad Unit
<b>Frequency resolution</b>	0.05 Hz or 0.1% of maximum frequency
<b>V/Hz Ratio</b>	0.24 - 8.85 (230 VAC models) 0.48 - 17.69 (460 VAC models)
<b>Acceleration and Deceleration Range</b>	Programmable 0.1 to 600 seconds to maximum frequency (2 Each)
<b>Maximum / Minimum Frequency</b>	Separately programmable to 400 Hz
<b>Preset Speeds</b>	Up to 8 available; programmable to maximum frequency

TABLE 1.3

## General Specifications (continued)

<b>Dynamic Braking</b>	Up to 60% for 6 sec. with standard DB resistor
<b>PWM Frequency</b>	7.8/9.2kHz (model dependent)
<b>Operating Controls</b>	1. Keypad                      3. Remote Keypad Unit 2. Terminal Strip        4. Program Memory Unit
<b>LED Indicators</b>	Red & Green for operation and fault annunciation (See Section 3.6)
<b>Keypad Display</b>	6 digit, backlit LCD with special annunciators and unit symbols
<b>Auxiliary Relay</b>	Programmed as Fault. Programmable to signal one of ten conditions
<b>Programming Levels</b>	Level 1 - Operator Level 2 - Engineer
<b>Input Control Terminals</b>	15; multi-functional; pull-up or pull-down logic
<b>Agency Listings</b>	UL & CUL Listed

TABLE 1.3 (continued)

## Protection Features

<b>Ground Fault</b>	Startup-all models; NEMA 4 models full-time; NEMA 1 and Chassis models full-time optional
<b>Short Circuit</b>	Protected from damage
<b>Motor Overload</b>	Programmable inverse time overload trip
<b>Overvoltage</b>	Protected from damage. 500 mS ride-through
<b>Undervoltage</b>	Protected from damage. 200 mS ride through, load dependent
<b>MOL Input Terminal</b>	Programmable for N.C. or N.O. contacts.
<b>Torque Limit</b>	Full time four quadrant "Trip-Free" operation
<b>Over Temperature</b>	Protected from damage, warning display

TABLE 1.4

## SECTION 2 INSTALLATION AND ENCLOSURE DIMENSIONS

### 2.1 General Rules for Installation

Improper installation of the inverter will greatly affect its life. Be sure to observe the following points when selecting a mounting location. **VIOLATING THE CONDITIONS LISTED BELOW MAY VOID THE WARRANTY!**

- Do not install the inverter in a place subjected to high temperature, high humidity, or excessive vibration. (See Table 1.4 for temperature, humidity and maximum vibration limits.)
- Mount the drive vertically and do not restrict the air flow to the heat sink fins.
- The E-trAC® XFC generates heat. Allow sufficient space around the unit, as shown in Figure 2.1.

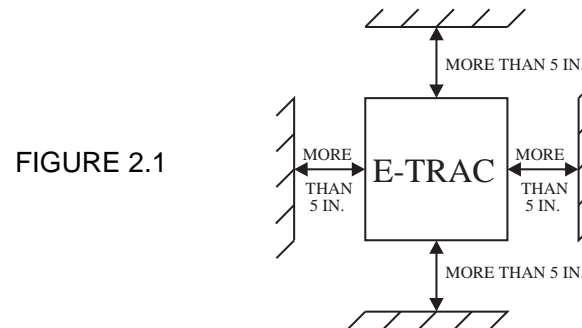

FIGURE 2.1

- When mounting a drive in another enclosure (with the fins inside the enclosure), consult TB Wood's for enclosure sizing and mounting instructions.
- Do not mount the E-trAC® XFC above heat generating equipment, or in direct sunlight.

## 2.2 Explosion Proof Applications

Explosion proof motors that are not rated for inverter use lose their certification when used for variable speed. Due to the many areas of liability that may be encountered when dealing with these applications, the following statement of Company Policy applies:

**TB Wood's Incorporated AC Inverter products are sold for suitability with explosion proof AC motors rated for use with PWM inverters. These motors must be UL listed for use with either TB Wood's AC inverters or with PWM inverters and used within the specified speed ranges and carrier frequencies. TB Wood's accepts no responsibility for any direct, incidental or consequential loss, cost or damage associated with the misapplication of our AC products in these applications. In any misapplication, the purchaser expressly agrees to assume all risk of loss, cost or damage that may arise. TB Wood's Incorporated will not knowingly approve the application of their AC inverters with motors not rated for such applications.**

## 2.3 Line starting

E-trAC® XFC is designed to provide controlled starting and stopping of AC motors by use of the keypad or external contacts connected to the control terminal strip. The drive may also be started by using a maintained contact (2-wire operation) and applying AC power to terminals L1, L2, and L3. To prevent accidental starting of the motor, the inverter has line-start-lockout as a standard feature. This provision can be defeated by programming 82-START (See Section 4.2).

**THE INVERTER MAY BE STARTED ONCE EVERY TWO (2) MINUTES IN THE LINE STARTING MODE.**

## 2.4 DIMENSIONAL DATA

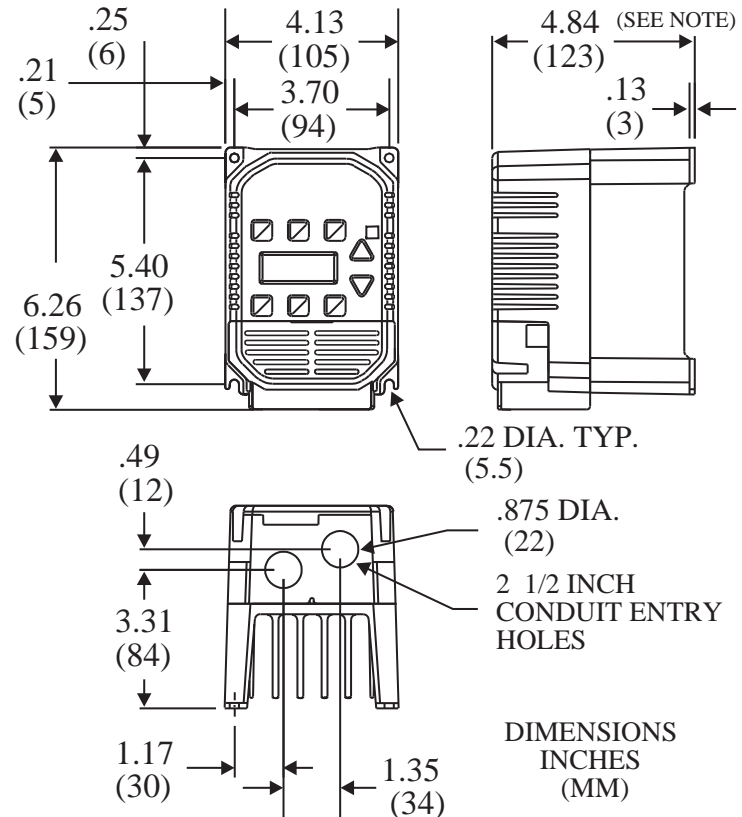

NOTE: CHASSIS MODELS SUPPLIED WITHOUT PLASTIC COVERS AND CONDUIT PLATES. DEPTH = 4.68 (119)

0.5 HP 115 VAC  
0.5 - 1.0 HP 230 & 460 VAC

FIGURE 2.2

**2.4 DIMENSIONAL DATA (continued)**

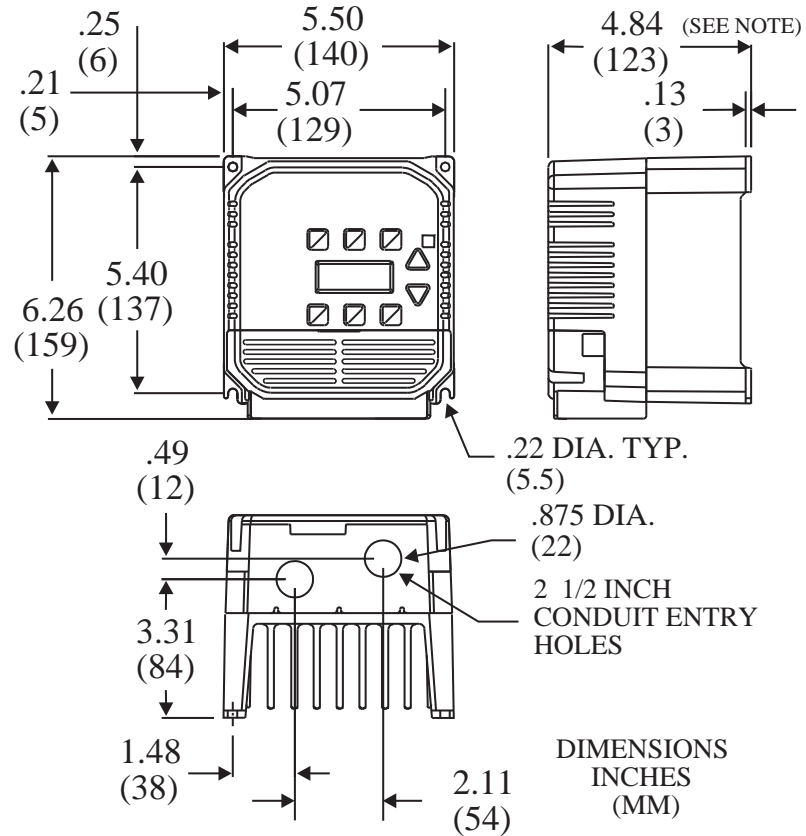

1.0 HP 115 VAC  
2.0 HP 230 & 460 VAC

FIGURE 2.3

**2.4 DIMENSIONAL DATA (continued)**

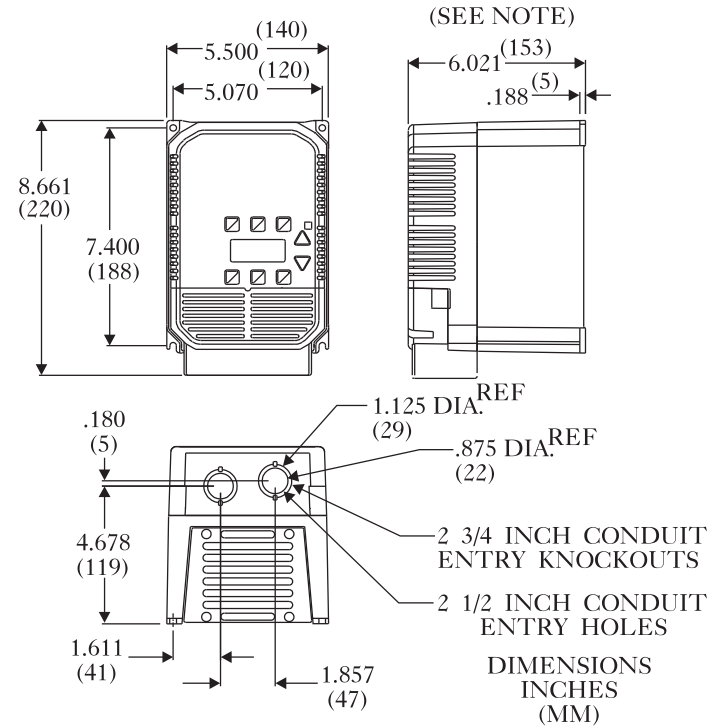

3 & 5 HP NEMA 1 Models

FIGURE 2.4



## 2.4 DIMENSIONAL DATA (continued)

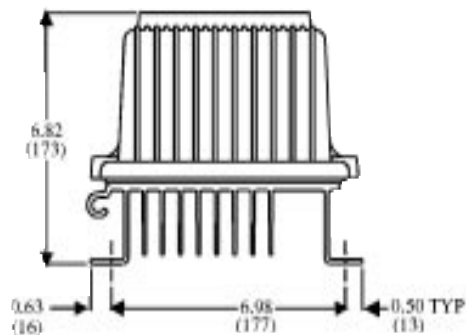
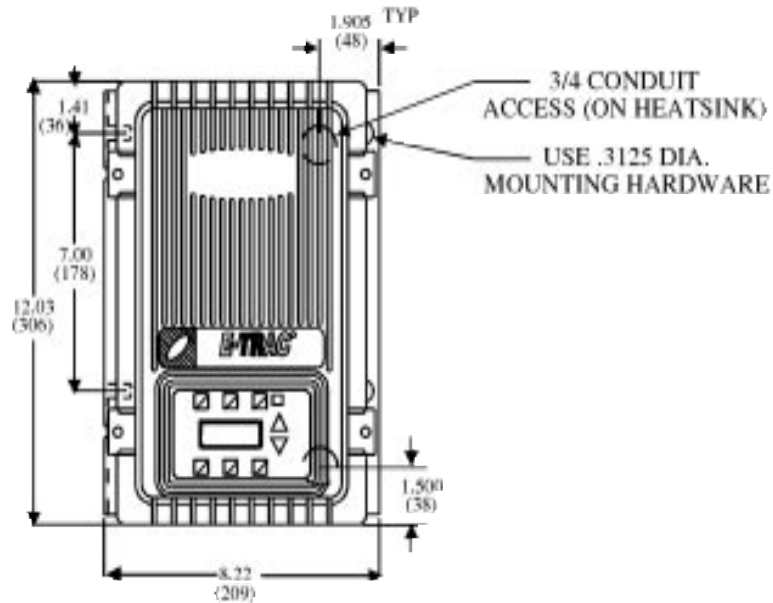

DIMENSIONS  
INCHES  
(MM)

FHP THROUGH 3 HP – 230V – NEMA 4  
1HP THROUGH 5HP – 460V – NEMA 4  
FIGURE 2.5

### WARNING

DISCONNECT ELECTRICAL SUPPLY BEFORE SERVICING THE ELECTRICAL SYSTEM.

### AVERTISSEMENT

COUPER L'ALIMENTATION AVANT D'ENREPRENDRE LE DEPANNAGE DU SYSTEME ELECTRIQUE.

## 2.5 Input AC Line Requirements

The allowable AC line voltage fluctuation is specified in Section 1.4. A supply voltage above or below these limits will cause the inverter to trip out with either an overvoltage or an undervoltage fault.

**NOTE:** If the source of the AC power to the E-trAC® XFC is greater than ten times the kVA rating shown in Table 2.1, an isolation transformer or line inductors are recommended. Consult the factory for help in sizing the inductors.

INPUT POWER TRANSFORMER RATINGS					
Rated Horsepower	0.5	1.0	2.0	3.0	5.0
Minimum kVA Rating	1.0	2.0	4.0	5.0	8.0

TABLE 2.1

**NOTE:** Caution must be exercised when applying E-trAC® XFC micro-inverters on low line conditions. For example, an E-trAC® XFC2000 series micro-inverter will operate properly on a 208 VAC line; however, the maximum output voltage will be limited to 208 VAC. If the motor is rated for 230 VAC line voltage,

higher motor currents and increased heating will result. **Ensure that the voltage rating of the motor matches the applied line voltage.** If other than 60 Hz output is desired, proper volts/hertz can be programmed into the inverter by the 53-FKNEE and 32-FMAX parameters. If you are unsure about this feature, consult the factory.

Phase voltage imbalance of the input AC source can cause unbalanced currents and excessive heat in the input rectifier diodes and in the DC bus capacitors of the inverter. Phase imbalance can also be damaging to motors running directly across the line.

**CAUTION: NEVER USE POWER-FACTOR CORRECTION CAPACITORS ON THE E-trAC® XFC MOTOR TERMINALS M1, M2, AND M3, OR DAMAGE TO THE SEMI-CONDUCTORS WILL RESULT.**

### A. Single Phase Operation

XFC2000 Series E-trAC® micro-inverters are designed for both three phase and single phase input power. If operating with single phase power, use line terminals **L1** and **L2**. The output of the drive will always be three phase. See Section 1.4 for applicable derating when using single phase input power and Section 5, Figure 5.1 for proper power connections. **Do not connect single-phase motors to the inverter output terminals M1, M2 or M3.**

## 2.6 AC Line Protection

The user must provide either a circuit breaker or a fused disconnect switch on the input AC line in accordance with all applicable electrical codes. The following rules should be used to select the correct size of the input line fuses or circuit breaker.

### A. Sizing

The E-trAC® XFC micro-inverter is able to withstand a 150% overload for 60 seconds. For applications with short intermittent loads over 100%, select a fuse or magnetic trip circuit breaker rated at 1.5 times the input current rating of the drive. For applications with repetitive load peaks above 100% select 1.7 times the input current (**See Section 1.4, Table 1.2 for input current ratings**). Minimum voltage rating for the protection device should be 250 VAC for XFC1000 & XFC2000 models, and 600 VAC for XFC4000 models.

### B. Fuse Type

The XFC inverter is able to withstand a 150% overload for 60 seconds. For maximum protection of the inverter, use the fuses listed in Table 2.2. Recommended suppliers are Bussman for 230VAC and 460VAC.

Model	Fuse	Model	Fuse
XFC1000-5	KTK-7 or KTK-R-7	XFC2005-0	KTK-40
XFC1001-0	KTK-15 or KTK-R-15	XFC4001-0	KTK-4 or KTK-R-4
XFC2000-5	KTK-3 or KTK-R-3	XFC4002-0	KTK-7 or KTK-R-7
XFC2001-0	KTK-10 or KTK-R-10	XFC4003-0	KTK-10 or KTK-R-10
XFC2002-0	KTK-15 or KTK-R-15	XFC4005-0	KTK-15 or KTK-R-15
XFC2003-0	KTK-25 or KTK-R-25		

TABLE 2.5

## 2.7 Wiring Practices

### A. Applicable Codes

All E-trAC® XFC models are Underwriters Laboratories, Inc. (UL™) and Canadian Underwriters Laboratories (CUL™) listed and therefore comply with the requirements of National Electrical Code (NEC) and the Canadian Electrical Code (CEC). Installations intended to meet UL™ and CUL™ requirements must follow the instructions provided herein as a minimum standard. Where local codes exceed these requirements, they must be followed. Refer to the E-trAC® technical data plate and the motor nameplate for electrical data.

### B. Power Wiring

Power wiring are those wires which are connected to terminals L1, L2, L3, M1, M2, and M3. Power wiring must be selected as follows:

1. Use only UL™ recognized wire.
2. Wire voltage rating must be a minimum of 300 V for 230 VAC systems, and 600 V for 460 VAC systems.
3. Wire gauge must be selected based on 125% of continuous output current rating of the drive. Wire gauge must be selected from wire tables for 60°C or 75°C insulation rating, and must be of copper construction. Refer to Table 1.2 for continuous output ratings.
4. Grounding must be in accordance with NEC and the CEC.

**NOTES: 1. Never connect input AC power to the motor output terminals M1, M2 and M3 or damage to the drive will result.**

2. Power delivered from variable frequency drives contains high frequencies which may cause interference with other equipment. Control wiring should not be run in the same conduit or raceway with power or motor wiring.

### C. Control Wiring

This is wiring connected to the control terminal strip (15 terminals). It must be selected as follows:

1. Shielded wire is recommended to prevent electrical noise interference from causing improper operation or nuisance tripping. Connect the shield to terminal **CM** (control common) on the E-trAC® XFC control terminal strip only.
2. Use only UL™ recognized wire.
3. Wire voltage rating must be a minimum of 300 V for 230 VAC systems, and 600 V for 460 VAC systems. This is Class 1 wire.
4. Never run the control wiring in the same conduit or raceway with power wiring. See NOTES above.

## 2.8 Reducing Current Surges and Voltage Transients

Inrush currents to the coils of magnetic contactors, relays and solenoids associated with, or in close proximity to, the inverter can induce high current spikes in the power and control wiring causing faulty inverter operation. If this condition occurs, a snubber network, consisting of a series resistor and capacitor for AC loads, or a free-wheeling or flyback diode for DC loads, should be placed across the relay coil.

For 115 VAC loads, TB Wood's part number **U4785**, or ITW Quencharc part number #104M06QC150 is suitable.

For magnetic contactors, relays and solenoids which are energized from a DC source, a free-wheeling diode should be used. The diode should be a high-speed, fast recovery type. Connect the diode across the coil with the cathode end toward the positive power source. The diode current and voltage should be selected by the following formula:

$$\text{Diode Current Rating (A)} \geq \frac{\text{Coil Capacity (VA)}}{\text{Rated Voltage of Coil (V)}}$$

$$\text{Diode Voltage Rating} \geq \text{Rated Voltage of Coil (V)} \times 2$$

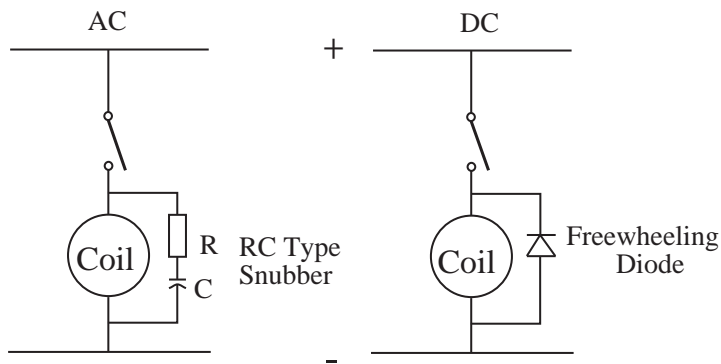

FIGURE 2.6

## 2.9 Function and Use of Terminals

Refer to Section 5 - Connection Diagrams for power and control wiring examples.

### A. Power Circuit Terminals

The power terminals are located on the E-trAC® power module, and are labeled **L1**, **L2**, and **L3** for incoming three phase AC line power, and **M1**, **M2**, and **M3** for the motor connections. Two ground connections (**GND**) are located on the upper left-hand side of the end plate on NEMA 1 models and on the heatsink on the chassis model. The screws are green and must be connected to earth ground in accordance with the NEC. **Note that for NEMA 4 units, L1, L2, and L3 must be run through the Ground Fault CT to maintain full-time ground fault protection** (see Figure 2.9).

### B. Control Terminals

The control terminals are located on the bottom edge of the inverter's control board. See Figure 2.8 and Section 2.11. These terminals are available for use with external devices.

**NOTE: Control input signals must not exceed 24 VDC ± 20% potential to ground.**

- Control terminal input impedance:
  - \* **VIN** terminal - 100 kΩ (0-5/10 VDC input)
  - \* **VIN** terminal - 250 Ω (0/4-20 mA input)
  - \* **FWD, REV, PS1, PS2, PS3, MOL**, - 4.5 kΩ

- Logic Input Levels:

LOGIC TYPE	PULL-UP	PULL-DOWN
ACTIVE	10 - 24 VDC	0 - 3 VDC
INACTIVE	0 - 3 VDC	10 - 12* VDC

\*Consult Factory Application Note #AN1 for higher voltages

**J19** selects active High or Low control inputs. (See Section 2.12)

### C. Terminal Access Cover Removal

NEMA 1 versions of E-trAC XFC are designed to prevent accidental removal of the terminal access cover. Enhancements to the mounting provisions have added to the protection against damage and injury to personnel. The mounting meets UL and NEC specifications for safety. To remove the access cover, loosen the two 8/32 screws (U1294) mounted at 45° angles at the lower corners of the access cover. Note that when replacing the screws, a snug fit only is required. Do NOT torque the screws or damage to access cover may result.

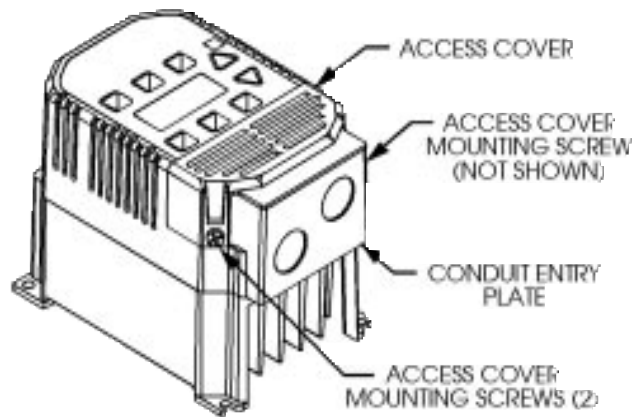

FIGURE 2.7

### D. NEMA 4 Cover Installation

To assure the environmental integrity of the NEMA 4 models, unused conduit fittings must be sealed. A conduit plug is pre-installed in the upper conduit hole.

Also, the cover screws must be properly tightened. After all electrical connections are made, swing the cover closed and torque all four (4) cover screws to a maximum torque of 10-15 in.lb. Tighten alternate corners to assure even compression of the enclosure gasket.

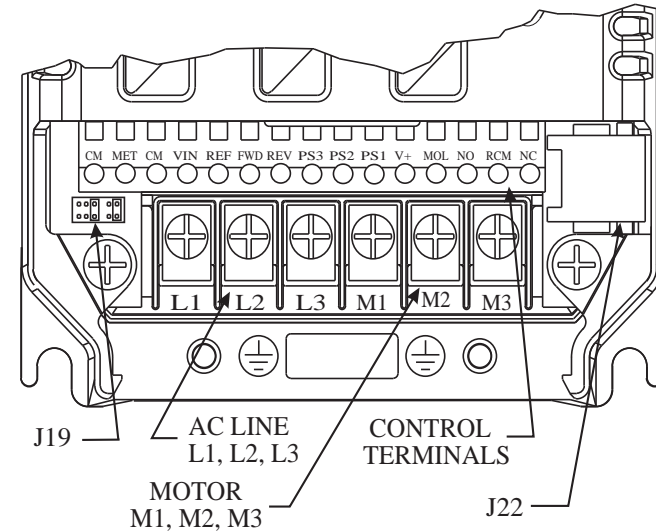

FIGURE 2.8

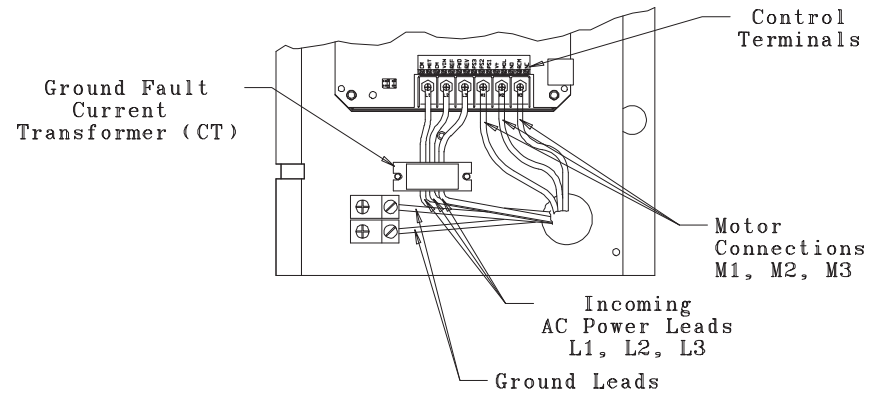

FIGURE 2.9

## 2.10 J22 Option Connector

Connector J22, located on the right side of the E-trAC® XFC micro-inverter, is used to interface with a number of external options (see Section 7.2). Keypad options interfaced thru J22 may be mounted up to 300 feet from the drive. Programmer options allow the storage of up to ten (10) separate parameter sets.

## 2.11 Input Terminal Usage

The E-trAC® XFC series micro-inverter has a 15 position control terminal block. Some functions are defined by the setting of jumper **J19**, while others are defined by programming. Refer to Section 5 - Connection Diagrams and Figure 2.8.

DESCRIPTION OF TERMINALS	
<b>CM</b>	Circuit Common, isolated from ground.
<b>MET</b>	Analog meter output providing a 0 to 10 VDC (1 mA Max.) signal proportional to Output Frequency, Load, or Current via setting of 71-METER. The output may be calibrated by programming 70-MCAL while running.
<b>VIN</b>	Analog speed input, <b>J19</b> jumper selectable for 0-5 VDC, 0-10 VDC or 0/4-20 mA DC. A 4 mA offset is programmed by 24-FSEL.
<b>REF</b>	5.2 VDC reference voltage, 3 mA maximum load. <b>USE ONLY FOR A FREQUENCY CONTROL POTENTIOMETER (5 kΩ Recommended)</b>
<b>FWD</b>	Digital input for Forward operation. May be programmed for maintained (standard) or momentary contacts by 21-MODE.
<b>REV</b>	Digital input for Reverse operation. May be programmed for maintained (standard) or momentary contacts by 21-MODE.
<b>V+</b>	Positive nominal 12 VDC voltage. Only for use with digital inputs. (See Section 5) NO OTHER USE IS ALLOWED.
<b>MOL</b>	Motor Overload Relay input. May be configured to generate a fault on opening or closing. May also be configured to command a Coast-To-Stop on opening or closing. See section 4.2, 77-MOL.

TABLE 2.3

DESCRIPTION OF TERMINALS				
<b>PS1</b> <b>PS2</b> <b>PS3</b>	Digital inputs normally used for preset speed selection. Jumper <b>J19</b> selects pull-up or pull-down logic (see Section 2.12). PS3 can define as a Run/Jog selector by 21-MODE or as the ART selector by 41-RSEL. Eight preset speeds are available if all 3 inputs are used, and four are available if PS3 is redefined via 21-MODE or 41-RSEL.			
	<b>PS1</b>	<b>PS2</b>	<b>PS3</b>	<b>EFFECTIVE SPEED REFERENCE</b>
	0	0	0	Basic speed setpoint (keypad or terminals)
	1	0	0	33-F2
	0	1	0	34-F3
	1	1	0	35-F4
	0	0	1	36-F5
	1	0	1	37-F6
	0	1	1	38-F7
1	1	1	32-FMAX	
<b>PS1</b> <b>PS2</b>	0	0	N/A	Basic speed setpoint (keypad or terminals)
	1	0	N/A	33-F2
	0	1	N/A	34-F3
	1	1	N/A	35-F4
<b>NO</b>	Normally open contact for the Auxiliary Relay. Will close when the relay is activated. Rating is 115 VAC at 1 Ampere			
<b>RCM</b>	Auxiliary relay common terminal. Factory programmed as a Fault relay but may be set to activate under one of ten conditions. See Section 4.2, 75-STR.			
<b>NC</b>	Normally closed contact for the Auxiliary Relay. Will open when the relay is activated. Rating is 115 VAC at 1 Ampere			

TABLE 2.3 (continued)

## 2.12 J19 Configuration

**J19** is a pin-jumper selector located below the terminal block on the left-hand side of the control board (See Figure 2.8). It has five (5) positions and two movable shorting jumpers. One jumper selects the analog speed reference used and the second jumper selects the active state (High or Low) of the digital inputs. A pair of small needle nose pliers will prove useful for moving these jumpers. **REMOVE AC POWER AND WAIT FOR ALL INDICATORS TO GO OUT BEFORE CHANGING THIS JUMPER.**

### Analog Reference Selection (24-FSEL selects direct or inverse operation)

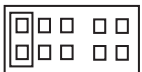

This configures the drive to accept an external 0-10 VDC speed reference signal. Input impedance is 100 k $\Omega$ .

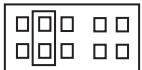

This configures the drive for either a 0-20 mA or a 4-20 mA input from an external source. 0 or 4 mA is selected by **24-FSEL**.

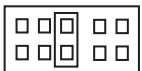

(DEFAULT SETTING) This configures the drive for an external 0-5 VDC signal, or a speed potentiometer powered from the REF terminal on the control terminal strip.

### Digital Input Logic Selection

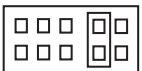

This configures the digital inputs for pull-down logic. That is, active when connected to terminal **CM**. Inputs are high, and are pulled low to activate.

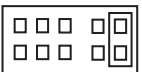

(DEFAULT SETTING) This configures the digital inputs for pull-up logic. That is, active when connected to terminal **V+**, or to an external power supply with its common connected to **CM**. Inputs are low and require a positive voltage to activate them. 0 to 3 VDC is INACTIVE, 10 to 24 VDC is ACTIVE.

## SECTION 3 GETTING STARTED

### 3.1 General Information

\* Some E-trAC<sup>®</sup> XFC Series micro-inverters do not include a digital keypad as standard equipment. These models are programmed to operate via the control terminal strip. They may be re-programmed using the optional keypad / programmer options outlined in Section 7.2.

\* Your E-trAC<sup>®</sup> XFC micro-inverter is pre-programmed to run a standard 4-pole AC induction motor; in many cases no additional programming is required.

\* The advanced digital keypad controls all operations of the inverter. The eight input keys allow “Press and Run” operation of the motor and straight forward programming of the parameters. To simplify the programming further, the parameters are separated into two Program Levels:

**LEVEL 1** Easily entered by pressing the **PROG** key at any time. Limits access to the most commonly used parameters for operator convenience.

**LEVEL 2** Accesses all parameters including those in Level 1. Used when the more advanced features are needed. It is entered by pressing and holding the **SHIFT** key then pressing the **PROG** key.

Parameters may only be programmed when the drive is stopped, with the exception of 70-MCAL which may be programmed at any time (See Section 4.2).

### 3.2 Digital Keypad

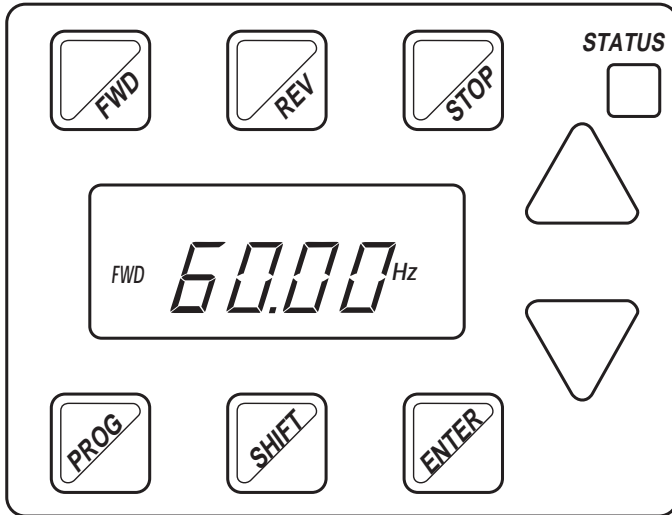

FIGURE 3.1

### 3.3 Keypad Operation

When 21-MODE is set to 0 or 10, start/stop and speed commands are accepted from the keypad. The keys are used to operate the inverter as described in Section 3.4

### 3.4 Operation Mode (RUN and STOP modes)

KEY	FUNCTION
<b>FWD</b>	Initiates forward run when pressed momentarily. If the drive is running in reverse when FWD is pressed, it will decelerate to zero speed, change direction, and accelerate to the set speed.
<b>REV</b>	Initiates reverse run when pressed momentarily. If the drive is running in forward when REV is pressed, it will decelerate to zero speed, change direction, and accelerate to the set speed.
<b>STOP</b>	Causes a Ramp-To-Stop when pressed. Programmable to Coast-To-Stop by 41-RSEL.
<b>UP</b>	In the Stop mode, pressing this key increases the desired running speed of the drive. In the Run mode, pressing this key increases the actual running speed of the drive. Setting resolution is 0.05 Hz up to 99.95 Hz and 0.1 Hz above this frequency. The display will scroll at an increased rate after holding the key for five seconds. Pressing SHIFT while holding the UP Arrow bypasses the delay.
<b>DOWN</b>	In the Stop mode, pressing this key decreases the desired running speed of the drive. In the Run mode, pressing this key decreases the actual running speed of the drive. Setting resolution is 0.05 Hz up to 99.95 Hz and 0.1 Hz above this frequency. The display will scroll at an increased rate after holding the key for five seconds. Pressing SHIFT while holding the DOWN Arrow bypasses the delay.
<b>ENTER</b>	In the Stop or Run modes, pressing this key will store the selected frequency as the initial operating frequency when the inverter is powered up. The frequency is maintained until another frequency is entered.
<b>PROG</b>	In Run mode, pressing this key will access Level 1 Parameters for Viewing only. Holding <b>SHIFT</b> and then pressing <b>PROG</b> will access Level 2. Any attempt to program (other than 70-MCAL) will result in a display that shows "----". In Stop mode, programming is allowed in both Level 1 and Level 2. See Section 3.5.

TABLE 3.1



### 3.5 Program Mode

KEY	FUNCTION
<b>PROG</b>	When in Stop mode, pressing this key will enter the Program mode at Level 1. Pressing the key at any time while in the Program mode will return the unit to the Operation mode. Pressing and holding <b>SHIFT</b> while pressing <b>PROG</b> will access Level 2. If an Access Code has been invoked, it must be entered to change Data Code. See Section 4.2, 87-ACODE.
<b>UP</b>	In the Program mode, pressing this key will move forward through the successive parameters. If the <b>PRG</b> indicator is flashing it increases the Data Code. The <b>ENTER</b> key must be pressed to store the Data Code.
<b>DOWN</b>	In the Program mode, pressing this key will move backward through the successive parameter addresses. If the <b>PRG</b> indicator is flashing it decreases the Data Code. The <b>ENTER</b> key must be pressed to store the Data Code.
	<b>NOTE:</b> If the <b>PRG</b> indicator is flashing, momentarily pressing and releasing both the <b>UP</b> and <b>DOWN</b> arrows simultaneously will return the Data Code to factory defaults. Press <b>ENTER</b> to store the new code.
<b>SHIFT</b>	Pressing this key while a parameter is displayed will allow that parameter to have its Data Code changed by use of the <b>UP</b> and <b>DOWN</b> arrow keys.
<b>ENTER</b>	This key must be pressed after the Data Code has been changed to store the new code. The display will show <b>STO</b> red for one second indicating that the Data Code has been entered into memory.

TABLE 3.2

### 3.6 Status Indicator

The STATUS indicator consists of two LEDs, one green and one red located in the upper right corner of the control board. They are visible through a lens in the upper right corner of the keypad on NEMA 1 or NEMA 4 models. The following table defines the STATUS indicator state for the various operating conditions of the inverter.

STATUS INDICATOR		OPERATING CONDITION
COLOR	DURATION	
Green & Red	Continuous	Power on, restart (2 Seconds)
Red	Continuous	Stop, running in torque limit
Green	Continuous	Run
Green & Red	Flashing	Running in and out of torque limit
Green	Flashing	Running in and out of an overvoltage or undervoltage condition
Red	Flashing	Drive faulted, emergency stop, line start lockout or low voltage

TABLE 3.3

### 3.7 Description of Displays

The custom, back-lit, LCD display provides information on drive operation and programming. The four large 7-segment displays show drive output and programming data. The two smaller digits are used to indicate parameter numbers in the Program mode. Special symbols and displays provide further clarification of drive operation. Figure 3.2 shows all segments displayed. In normal operation only those segments that are active are displayed.



FIGURE 3.2

Table 3.4 lists the special annunciators and their meaning.

SYMBOL	DESCRIPTION
<b>FWD</b>	Forward direction commanded
<b>REV</b>	Reverse direction commanded
<b>PRG</b>	Program mode selected (continuous) Data Code may be changed (flashing)
<b>SET</b>	Drive is stopped, or is having the running frequency set
<b>OV</b>	Drive is in an overvoltage condition
<b>UV</b>	Drive is in an undervoltage condition
<b>LIM</b>	Drive is running in torque limit
<b>OC</b>	Drive is in (flashing) or has tripped (continuous) due to an overcurrent condition
<b>TEMP</b>	Drive is near (flashing) or has tripped (continuous) due to an over temperature condition
<b>DB</b>	The standard Dynamic Brake circuit is active
<b>rpm</b>	Revolutions per minute indication
<b>Hz</b>	Frequency in Hertz
<b>h</b>	Time in hours
<b>s</b>	Time in seconds
<b>A</b>	Output current indication in Amperes
<b>V</b>	Output voltage indication in Volts
<b>%</b>	Display is in percent of units
<b>C</b>	Degrees centigrade

TABLE 3.4

### 3.8 Parameter Access

\* When the **PROG** (or **SHIFT-PROG**) key is pressed after the application of power or a fault reset, **21-MODE** will always be the first parameter displayed. See Section 4.1 for programming instructions.

\* If a different parameter is accessed and the Program mode is exited, that parameter will be the point of entry the next time the Program mode is accessed.

\* The E-trAC® XFC will remember a different “last parameter accessed” for Levels 1 and 2.

\* If no key is pressed for 10 minutes while in the Program mode, the drive will automatically revert back to the operating mode.

### 3.9 Display Scroll Rate

Three scroll rates are used to speed data entry.

\* If either the **UP** or **DOWN** arrow is pressed and held for five seconds, the scroll rate will increase.

\* If the **SHIFT** key is momentarily pressed while pressing one of the arrow keys, the five second delay will be bypassed.

\* If the **SHIFT** key is pressed a second time while pressing an arrow key the display will scroll at the fastest rate.

### 3.10 Restoring Factory Settings

\* Whenever a parameter Data Code is being changed (noted by **PRG** flashing) the original factory setting for that parameter can be restored by pressing and releasing both the **UP** and **DOWN** arrows simultaneously and then pressing the **ENTER** key.

\* To restore **ALL** parameters to factory settings, or recall a previously stored parameter set, see Section 4.2 **81-PRGNO**.

### 3.11 Help

\* For Application Assistance, call TB Wood's Electrical Application Engineering at 800-789-6637.

### 3.12 Quick Start

This section is for operators with simple applications who would like to get up and running quickly and with a minimum amount of reading of the manual. **Be sure to read sections 3.1 through 3.8 before proceeding.** In many cases your E-trAC® XFC will perform perfectly without making any changes to the factory settings. This section assumes that the E-trAC® XFC has either a standard keypad or remote keypad attached. If remote operators are being used, substitute the speed potentiometer for the UP and Down arrows and the remote Run/Stop switch for the FWD key in the following instructions.

- A. Perform all procedures for installation as specified in Section 2 - Installation Instructions.

**RE-VERIFY THAT THE PROPER VOLTAGE IS CONNECTED TO THE INVERTER BEFORE APPLYING POWER. FAILURE TO DO THIS CAN RESULT IN PERSONAL INJURY AND EQUIPMENT FAILURE!**

- B. Apply AC power to the input terminals. For about two seconds the display will show all segments active (See Figure 3.2). The STATUS indicator will then turn red (indicating a Stop condition) and the display will change to:



FIGURE 3.3

- C. The factory settings are for keypad only operation in the forward direction. This means that the REV key is disabled. Press the FWD key, the display will change to:



FIGURE 3.4

- D. Press the UP Arrow to increase the desired running frequency. When the display gets to 0.1 Hz, the inverter will start to produce an output. When the motor starts to turn, check the rotation. If the motor is turning in the wrong direction, **PRESS STOP, REMOVE AC POWER AND WAIT FOR ALL INDICATORS TO GO OUT.** After the STATUS indicator has gone out, reverse any two of the motor leads at M1, M2 or M3.
- E. The length of time that the UP Arrow is pressed determines the scroll rate of the display. After it is held for five seconds, the rate of change will increase. The five second time can be circumvented by momentarily pressing the SHIFT key while holding the UP (or DOWN) Arrow.
- F. The inverter is preset to run a “typical” NEMA B 4-pole induction motor to a maximum speed of 60.00 Hz with both Acceleration and Deceleration times set to 3.0 seconds. See the Parameter Code Summary (inside front cover) for a complete list of all factory settings.
- G. Use the Arrow keys to set the proper running speed of the motor and the FWD and STOP keys to control it's operation.

## SECTION 4 PARAMETER DESCRIPTIONS AND PROGRAMMING

Level 1 - Accesses only basic operator parameters.  
 Level 2 - Accesses all parameters including those in Level 1.

### 4.1 Programming

Refer to Figures 3.1 and 4.1.

To change the default Data Code in a given parameter:

- A. Press the **STOP** key to stop the inverter if running.
- B. Press the **PROG** key to enter Level 1 Program mode. To enter Level 2 press and hold the **SHIFT** key and then the **PROG** key. The **PRG** indicator will turn on.
- C. Press the **UP/DOWN** arrow keys to access the desired parameter. The parameter number will be displayed in the upper left corner of the digital display.
- D. Press the **SHIFT** key to allow the Data Code to be changed. **PRG** will start to blink.
- E. Press the **UP/DOWN** arrows to select the new Data Code.
- F. Press the **ENTER** key to store the new Data Code. The display shows **STO**red for one second.
- G. Press the **PROG** key to exit the Program mode or the **UP/DOWN** arrows to select a new parameter.



FIGURE 4.1

### 4.2 Parameter Descriptions

This section provides functional descriptions of all E-trAC® XFC parameters. Level numbers with an asterisk (\*) indicate parameters that cannot be programmed, only viewed.

Note: Setting resolution is 0.05 up to 99.95 and 0.1 above this point unless otherwise noted.

<u>Parameter</u>	<u>Units</u>	<u>Level</u>
<b>02-RVLVL</b> - Software Revision		L2*
This parameter holds the identification code of the Read Only Memory.		
<b>03-IRAT</b> - Inverter Rated Current	[A]	L2*
This defines the nominal output current of the inverter and serves as the 100% reference for all current measurements. Continuous drive capacity is 1.1 times 03-IRAT.		
<b>07-FLT3</b> - Last Fault		L1*
<b>08-FLT2</b> - Second Fault		L2*
<b>09-FLT1</b> - First Fault		L2*
This defines the most recent faults. The two left most digits are the fault code, and the right most is elapsed time in 0.1 hr increments, since the last restart of the drive, 0.9 hours max. See Section 6.2.		
<b>12-FOUT</b> - Motor Output Frequency	[Hz]	L1*
Inverter output frequency (Hz) applied to the motor.		

<u>Parameter</u>	<u>Units</u>	<u>Level</u>
<b>13-VOUT</b> - Motor Output Voltage Motor output voltage calculated as a percent of applied line input voltage.	[%]	L1*
<b>14-IOUT</b> - Motor Output Current Motor phase current computed to an accuracy of ± 20%.	[A]	L1*
<b>15-LOAD</b> - Drive Load True part of motor current. Output current measurement with motor power factor applied. Accuracy is ± 20%. Load reading is positive in motoring mode, and negative in regenerative mode.	[%]	L1*
<b>16-TORQ</b> - Load Torque Torque output of the motor. Computed from 15-LOAD, taking into account constant horsepower operation when 12-FOUT is greater than 53-FKNEE. Regenerative torque is shown with a negative sign.	[%]	L1*
<b>17-TEMP</b> - Drive Temperature Inverter heatsink temperature. The inverter will turn off when this temperature exceeds its maximum allowed temperature. This display is accurate to ±3°C.	[°C]	L1*

<u>Parameter</u>	<u>Units</u>	<u>Level</u>
<b>21-MODE</b> - Input Mode The MODE parameter defines the source for speed reference and Run/Stop control input.		L1

<u>DATA CODE</u>	<u>SPEED CONTROL</u>	<u>START/STOP CONTROL</u>
0	KEYPAD	KEYPAD (FWD Only)
10	KEYPAD	KEYPAD (FWD & REV)
1	VIN TERMINAL	KEYPAD (FWD Only)
11	VIN TERMINAL	KEYPAD (FWD & REV)
2	KEYPAD	TERMINALS (2-Wire Maintained Contact)
3	VIN TERMINAL	TERMINALS (2-Wire Maintained Contact)
4	KEYPAD	TERMINALS (3-Wire Momentary, RUN/JOG via PS3)
5	VIN TERMINAL	TERMINALS (3-Wire Momentary, RUN/JOG via PS3)
6	EMOP	TERMINALS
	(2-Wire, See Section 5.6 and table below)	
7	EMOP	TERMINALS
	(3-Wire, See Section 5.6 and table below)	

EMOP Control Terminal Logic Table

<u>DESCRIPTION</u>	<u>FWD</u>	<u>REV</u>	<u>PS1</u>	<u>PS2</u>
<b>STOP</b>	0	0	X	X
<b>Speed = 0</b>	1	1	X	X
<b>FWD Decrease</b>	1	0	1	X
<b>FWD Hold</b>	1	0	0	0
<b>FWD Increase</b>	1	0	0	1
<b>REV Decrease</b>	0	1	1	X
<b>REV Hold</b>	0	1	0	0
<b>REV Increase</b>	0	1	0	1

X = "Don't Care"

**Parameter** **Units** **Level**

**24-FSEL** - Speed Setpoint Selector L2  
 Selects the speed setpoint characteristics and the offset if required. Also see J19 Selection (Section 2.12).

DATA CODE	OPERATION	OFFSET	INPUT SIGNAL
0	DIRECT	0	0-10 VDC, 0-5 VDC, 0-20 mA
1	INVERSE	0	0-10 VDC, 0-5 VDC, 0-20 mA
2	DIRECT	20%	4-20 mA
3	INVERSE	20%	4-20 mA

NOTE: DIRECT = maximum output (**32-FMAX**) at maximum input.  
 INVERSE = minimum output (**31-FMIN**) at maximum input.

**31-FMIN** - Minimum Frequency [Hz] L1  
 Sets the minimum frequency to the motor. Programmable from 0 to 400 Hz. Minimum programmable output frequency is 0.1 Hz.

**32-FMAX** - Maximum Frequency [Hz] L1  
 Sets the maximum frequency to the motor. Programmable from 20 to 400 Hz.  
**Consult motor manufacturer if frequency is in excess of nameplate rating.**

**33-F2 through 38-F7** - Preset Frequencies [Hz] L2  
 Programmable from 0 to 400 Hz. Selected with input terminals PS1, PS2 and PS3 (See Sections 2.11 & 5.6). May be set to a frequency greater than 32-FMAX, but the output **WILL NOT** exceed 32-FMAX when running. **Consult motor manufacturer if frequency is in excess of motor nameplate rating.**

**Parameter** **Units** **Level**

**39-FTL** - Minimum Frequency in Torque Limit [Hz] L2  
 This parameter sets the lowest frequency that the drive will decelerate to when in torque limit. If the load is large enough to drive the inverter below this threshold, the drive will trip on overcurrent.  
 1. The rate of deceleration is set by 46-DECTL.  
 2. Programmable from 0 to 400 Hz. Factory set for 10 Hz.  
 3. To disable Torque Limit, set this to a Data Code greater than 32-FMAX.

**41-RSEL** - Ramp Selector L2  
 Selects the Acceleration and Deceleration ramps that control the motor and also enables the coast-to-stop function.

DATA CODE	DEFINITION
0	Ramp-to-stop with 42-ACC1 and 43-DEC1 active.
1	42-ACC1/43-DEC1 active in Forward, 44-ACC2/45-DEC2 active in Reverse.
2	42-ACC1/43-DEC1 active when the output frequency is less than preset frequency 37-F6, 44-ACC2/45-DEC2 active when output frequency is equal to or greater than 37-F6.
3	When 21-MODE is programmed for 2, 3 or 6, PS3 is re-defined as the Alternate Ramp Time (ART) selector. When this terminal is active, 44-ACC2 and 45-DEC2 are selected. Note that PS3 cannot be used as a Preset Speed selector when 41-RSEL = 3 (See Table 2.2 and 21-MODE).
4	Same as 0, except coast-to-stop is selected when stopping.
5	Same as 1, except coast-to-stop is selected when stopping.
6	Same as 2, except coast-to-stop is selected when stopping.
7	Same as 3, except coast-to-stop is selected when stopping.

<u>Parameter</u>	<u>Units</u>	<u>Level</u>
<b>42-ACC1</b> - Acceleration Time #1 Sets the length of time to accelerate from 0 Hz to 32-FMAX. Programmable from 0.1 to 600 seconds. Extremely short acceleration times may result in nuisance fault trips. (See 41-RSEL)	[s]	L1
<b>43-DEC1</b> - Deceleration Time #1 Sets the length of time to decelerate from 32-FMAX to 0 Hz. Programmable from 0.1 to 600 seconds. Extremely short deceleration times may result in nuisance fault trips or may require external dynamic braking resistor (consult factory). (See 41-RSEL)	[s]	L1
<b>44-ACC2</b> - Acceleration Time #2 Alternate Acceleration Ramp. Sets the length of time to accelerate from 0 Hz to 32-FMAX. Programmable from 0.1 to 600 seconds. Extremely short acceleration times may result in nuisance fault trips. (See 41-RSEL)	[s]	L2
<b>45-DEC2</b> - Deceleration Time #2 Alternate Deceleration Ramp. Sets the length of time to decelerate from 32-FMAX to 0 Hz. Programmable from 0.1 to 600 seconds. Extremely short deceleration times may result in nuisance fault trips or may require external dynamic braking resistor (consult factory). (See 41-RSEL)	[s]	L2
<b>46-DECTL</b> - Deceleration Time in Torque Limit This parameter sets the deceleration rate when the drive is operating in torque limit mode. Programmable from 0.1 to 30 seconds. It also serves as the acceleration rate when the drive is in torque limit due to a regenerative condition. (See 39-FTL)	[s]	L2

<u>Parameter</u>	<u>Units</u>	<u>Level</u>
<b>47-DCBRK</b> - DC Brake Time This is the time in seconds that DC current will be applied to the motor windings with the following conditions:  1. Data Code = 0 A. DC braking disabled in all modes.  2. Data Code = 0.05 - 4.95 (Timed DC braking) A. In terminal strip Stop/Start, when both FWD and REV terminals are active. B. In FWD or REV run mode and the speed reference is reduced to less than 0.1 Hz. C. A Stop command is given and the output frequency decelerates to less than 0.1 Hz.  3. Data Code = 5 (Continuous DC braking) A. In terminal strip Start/Stop, as long as both FWD and REV terminals are held active. B. In FWD or REV run mode and the speed reference is reduced to less than 0.1 Hz. C. There is no DC braking after a normal deceleration to stop.	[s]	L2
<b>48-DCVLT</b> - DC Brake Voltage This controls the amount of DC voltage applied to the motor windings by 47-DCBRK. Programmable from 0 to 15% of the input voltage rating. Factory setting is model dependant.	[%]	L2

**CAUTION: If DC Braking is used as a holding brake, excessive motor heating may result.**

**Parameter** **Units** **Level**

**51-VSEL** - V/Hz Characteristic Selector L2  
 Three V/Hz characteristics (constant torque, pump and fan curves) and two starting torque boost features may be selected.

DATA CODE	DESCRIPTION
0	Linear V/Hz, with Auto-Boost, used with constant torque applications. With Auto-Boost, the optimum boost will be selected depending on load and motor conditions, parameter 52-BOOST sets the maximum boost applied.
1	Linear V/Hz, with constant boost fixed by 52-BOOST.
2	Mixed (linear/quadratic) V/Hz, with Auto-Boost, typical of pumping applications.
3	Mixed V/Hz, with constant boost fixed by 52-BOOST.
4	Quadratic V/Hz, with Auto-Boost, for fan-law applications.
5	Quadratic V/Hz, with constant boost fixed by 52-BOOST.

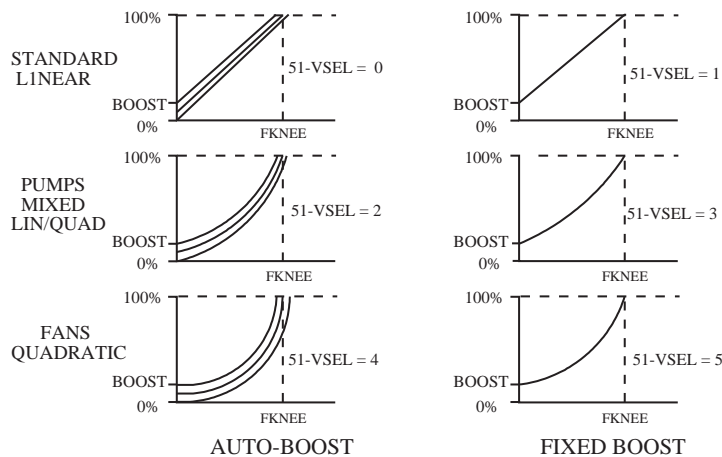

FIGURE 4.2

**Parameter** **Units** **Level**

**52-BOOST** - Torque Boost [%] L1  
 This parameter increases motor voltage at low speed as a percent of nominal voltage to increase the starting torque of the motor. Voltage boost will linearly decrease with increasing speed. Default Boost settings vary between models.

**NOTE: Care must be exercised with this adjustment. Too much torque boost may cause excessive motor currents and motor heating. Use only as much boost as is necessary to start the motor. Auto-Boost may be selected at parameter 51-VSEL to provide the optimum value of boost to suit the load automatically.**

**53-FKNEE** - V/Hz Knee Frequency [Hz] L2  
 This parameter sets the point on the frequency scale at which the output is at full line voltage. Programmable from 26 to 960 Hz. This is normally set at the base frequency of the motor but may be increased to enlarge the constant torque range on special motors. Setting FKNEE to a higher value can reduce motor losses at low frequencies.

**59-MVOLT** – Rated Motor Voltage [V] L2  
 This sets the voltage the inverter delivers to the motor terminals at the setting of 53-FKNEE. 230 volt models are programmable from 185 to 240 volts and 460 volt models from 370 to 480 volts. The drive will attempt to regulate the output voltage with a changing input voltage to better than 5%.

**61-LTLF** - Load Torque Limit Forward [%] L2  
**62-LTLR** - Load Torque Limit Reverse [%] L2  
**63-RTL** - Regenerative Torque Limit Forward [%] L2  
**64-RTL** - Regenerative Torque Limit Reverse [%] L2

These four parameters set the torque limiting points for the inverter in both motoring and regenerative modes with individual settings for forward and reverse operation. Programmable in 1% increments from 30 to 150% (110% in regenerative modes). TO DISABLE TORQUE LIMITING SET 39-FTL TO A VALUE GREATER THAN 32-FMAX.



**Parameter** **Units** **Level**

**65-SLIP** - Slip Compensation [%] L1  
 This parameter allows for compensation of slip in standard NEMA rated induction motors. Programmable from 0 to 12%. **DO NOT USE THIS FUNCTION WITH SYNCHRONOUS MOTORS, AS GROSS INSTABILITY MAY OCCUR.** Slip compensation is calculated as follows:

$$65\text{-SLIP} = \text{SLIP} \times (\text{IRAT}/\text{FLA}) \times 100$$

Where: IRAT = Data Code in 03-IRAT  
 FLA = Motor Nameplate Current  
 SLIP = (sync. speed - nameplate speed)/sync. speed

This parameter is inactive for 65-SLIP = 0

**66-STAB** - Current Stability Adjustment

Lightly loaded motors may tend to oscillate and become unstable due to electro-mechanical relationships in the motor. This may be more prevalent when the inverter capacity is larger than the motor. This adjustment will stabilize the motor current in these conditions. The value of 66-STAB is either 0 or 1, with the default being 1.

**67-TOL** - Timed Overload Trip Point [%] L1

This parameter defines the level of load that will cause a timed electronic overload trip to occur. Programmable in 1% increments from 0 to 100%. Trip time depends on overload severity, and is 1 minute for 150% of the 67-TOL setting. 67-TOL is active between 30 and 100% of the inverter rated current (03-IRAT).

**NOTE: When operating multiple motors from a single inverter, use a separate external motor protection device on each motor and set parameter 67-TOL to its factory setting of 0 (disabled).**

**Parameter** **Units** **Level**

Timed Overload is calculated as follows:

$$\text{TOL} = (\text{FLA}/\text{IRAT}) \times 100$$

Where:

IRAT = Data Code in 03-IRAT  
 FLA = Motor Nameplate Current

This parameter is inactive for 67-TOL = 0

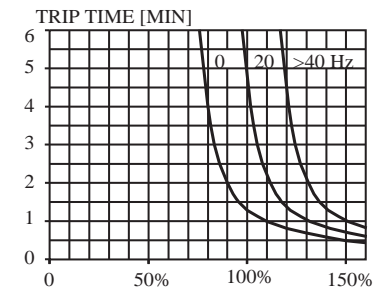

FIGURE 4.3

**68-NRST** - Trip Restart Number L2

**WARNING**

**INSURE THAT AUTOMATIC RESTARTING WILL NOT CAUSE DAMAGE TO EQUIPMENT OR INJURY TO PERSONNEL.**

**AVERTISSEMENT**

**ASSUREZ VOUS QU'UN DEPART AUTOMATIQUE N'ENDOMMAGERA PAS L'ÉQUIPEMENT OU DE BLESSURE AU PERSONNEL.**

The inverter will automatically perform a reset, after delay set by 69-DRST, from 1 to 8 times when any fault trip with a code of F11 and greater has occurred. If the FWD or REV terminal is still active (2-wire operation) the inverter will attempt a restart (See 21-MODE and Section 5.2). The count will reset if a another fault is not incurred within 10 minutes. If the programmed count is exceeded within 10 minutes, the inverter will not restart, but will display a fault trip message F10. **RESETTING THE FAULT CAN RESULT IN INSTANT STARTING. SEE WARNING ABOVE.**

This function is inactive for 68-NRST = 0.

**Parameter** **Units** **Level**

**69-DRST** - Restart Delay Time [s] L2  
 After a fault trip of F11 or greater has occurred, and 68-NRST is greater than zero, the inverter will wait for the specified number of seconds before attempting a restart. Programmable from 0 to 60 seconds in 1 second increments. Restart will be controlled by the setting of 82-START.

**70-MCAL** - Analog Meter Output Calibration L1

This parameter adjusts the meter output value at terminal MET. Programmable from 0 to 255. **70-MCAL can be programmed while the inverter is running.**

Factory default is for 10 VDC at terminal MET, at nominal full scale output.

**71-METER** - Analog Meter Output Selector L1

This parameter selects the analog output signal to be indicated at terminal MET. The factory full scale setting is 10 VDC but can be changed using parameter 70-MCAL.

DATA CODE	DESCRIPTION
0	Output off
1	Output proportional to output frequency (12-FOUT), with full scale at 32-FMAX.
2	Output proportional to output current (14-IOUT), with full scale at 200% of rated current.
3	Output proportional to inverter load (15-LOAD), with full scale at 200% of rated load.

**Parameter** **Units** **Level**

**75-STR** - Auxiliary Relay Output L1  
 The relay furnished with the inverter may be programmed to respond to any of the 10 conditions listed below. (See Section 2.11)

DATA CODE	DESCRIPTION
0	Off
1	Ready. The relay becomes active when the inverter is ready. It is inactive in Fault, Low Voltage and Program Modes.
2	Fault. The relay becomes active on Fault. See Note below.
3	Motor running Forward or Reverse, and output frequency above 0.5 Hz.
4	Motor running Reverse, and output frequency above 0.5 Hz.
5	Motor running Forward, and output frequency above 0.5 Hz.
6	Motor Speed = less than 0.5 Hz.
7	Motor at commanded speed.
8	Motor speed greater than preset speed 36-F5.
9	In Torque Limit.
10	Over temperature warning. Temperature is within 10°C of maximum temperature.

**NOTE: When automatic fault reset and restart is used (68-NRST), a fault will not be indicated until 69-NRST has been exceeded.**

**Parameter****Units Level****77-MOL** - Motor Overload Input

L2

Sets motor overload input function and polarity. This parameter, along with **J19** jumper selection, define the function of the **MOL** input terminal. It can be defined to generate an F07 fault or a Coast-to-Stop condition using either normally open or normally closed contacts. **J19** sets the input terminals for pull-up or pull-down logic (See Section 2.12).

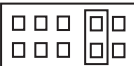
J19	DATA CODE	DESCRIPTION (MOL CONNECTION)
	0	High input (V+) or external signal (max +24 VDC referenced to CM) will generate an F07 Fault. (N.O. operation)
	1	Removal of high input (V+) or external signal will generate an F07 Fault. (N.C. operation)
	2	High input (V+) or external signal (max +24 VDC referenced to CM) will generate a Coast-to-Stop. (N.O. operation)
	3	Removal of high input (V+) or external signal will generate a Coast-to-STOP. (N.C. operation)
	0	Connecting MOL to CM will generate an F07 Fault. (N.O. operation)
	1	Opening MOL-CM connection will generate an F07 Fault. (N.C. operation)
	2	Connecting MOL to CM will generate a Coast-to-Stop. (N.O. operation)
	3	Opening MOL-CM connection will generate a Coast-to-Stop. (N.C. operation)

**NOTE: External thermal overload relay rating = 1.1 x motor continuous nameplate amps.**

**Parameter****Units Level****81-PRGNO** - Special Program Number

L2

This parameter allows for storing and resetting parameters and activating special functions. The function will be executed upon exiting the Program mode.

DATA CODE	DESCRIPTION
0	Standard Program
1	Reset parameters to factory settings (Display = <b>SETP</b> )
2	Store customer parameter settings (Display = <b>STOC</b> )
3	Recall customer parameter settings (Display = <b>SETC</b> )

**82-START** - Start Options

L2

Controls the operation of line start lock-out and/or Auto-Start into a rotating motor. Additionally enables or disables both the STOP key as an E-Stop when operating from the terminal strip and the Stop function due to a disconnection of a remote device connected to the drive through connector J22. See Section 6.1 for special display indications used with this parameter.

**WARNING**

**STARTING INTO A ROTATING MOTOR  
A LIGHTLY LOADED MOTOR MAY SUDDENLY ACCELERATE BEFORE  
LOCKING IN THE PROPER SPEED. ENSURE THAT THIS OPERATION  
WILL NOT CAUSE INJURY TO PERSONNEL OR DAMAGE TO  
EQUIPMENT.**

**AVERTISSEMENT**

**UN MOTEUR LÉGEREMENT CHARGÉ PEU ACCÉLÉRER  
SOUDAINEMENT AVANT D'ATTEINDRE LA VITESSE COMMANDER.  
ASSUREZ VOUS QUE CETTE CONDITION NE CAUSERAS PAS DE  
DOMMAGE À L'ÉQUIPEMENT OU DE BLESSURE AU PERSONNEL.**

DATA CODE	DESCRIPTION
0	Line Start Lock-out. If maintained contact run operators are used, they must be opened and then re-closed for the drive to start after application of AC power. STOP key active as Emergency, Coast-To-Stop, for 21-MODE = 2-7. To reset an E-Stop, press the STOP key again. No Stop with signal loss at connector J22.
1	Auto-Start. Will start on power-up if direction connection is made at the control terminals after application of AC power. STOP key active as Emergency, Coast-To-Stop, for 21-MODE = 2-7. To reset an E-Stop, press the STOP key again. No Stop with signal loss at connector J22.
2	Start into a rotating motor with Line Start Lock-out. (See Note on starting into a rotating motor). STOP key active as Emergency, Coast-To-Stop, for 21-MODE = 2-7. To reset an E-Stop, press the STOP key again. No Stop with signal loss at connector J22.
3	Start into a rotating motor with Auto-Start. STOP key active as Emergency, Coast-To-Stop, for 21-MODE = 2-7. To reset an E-Stop, press the STOP key again. No Stop with signal loss at connector J22.
4-7	Same Start functions as Data Codes 1-3, but Keypad STOP key will be disabled if Start/Stop is defined as terminals by 21-MODE. No Stop with signal loss at connector J22.
8-11	Same Start functions as Data Codes 1-3, but drive will initiate a Stop function (as defined by 41-RSEL) if a remote device signal is sensed at connector J22 and then lost.

**Parameter**

**Units Level**

**84-DISP** - Display Option Setting

L2

This parameter determines information displayed on the LCD readout during Run operation. The display will always show frequency in the Stop mode and while the speed is being set.

DATA CODE	DESCRIPTION
0	Output Frequency in Hz (value of 12-FOUT).
1	Output Current in Amps (value of 14-IOUT).
2	Drive Load in percent (value of 15-LOAD).
3-3000	Display indicates <b>rpm</b> . Number Displayed x 20 / 12-FOUT = Data Code Example: To display 1800 rpm at 60 Hz: $1800 \times 20 / 60 = 600$ Note: Data Code must be rounded to nearest whole number.

**87-ACODE** - Security Access Code

L2

Entering a number between 1 and 999 provides controlled access to program parameters (both Level 1 and Level 2). After an access code has been entered, the initial display will indicate:



After the proper security code is entered, the display will return to the normal Programming mode display. At this point, the user has 10 minutes of free access unless power is removed and reapplied.

## SECTION 5 CONNECTION DIAGRAMS

**WARNING**  
**TWIST WIRES TOGETHER BEFORE INSERTING IN TERMINAL.**  
**AVERTISSEMENT**  
**ENROULEZ LE FILS ENSEMBLE AVANT DE LES INTRODUIRE DANS LA BORNE.**

The following show some of the commonly used connections for operating the E-trAC® XFC from external devices. Refer to Section 2.11 for more information on the control input terminals.

### 5.1 AC Line and Motor Connections

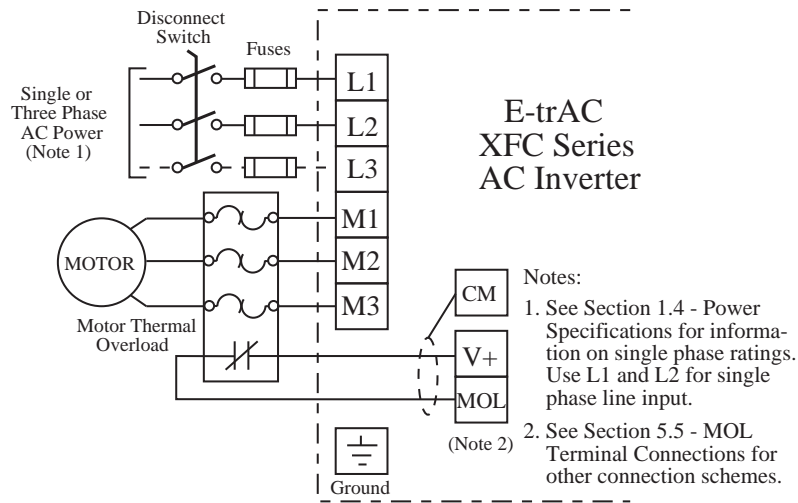

FIGURE 5.1

**Note:** This equipment is suitable for use on a circuit capable of delivering not more than 5000 rms symmetrical amperes at 10% above maximum rated voltage.

### 5.2 2-Wire Run/Stop Connections

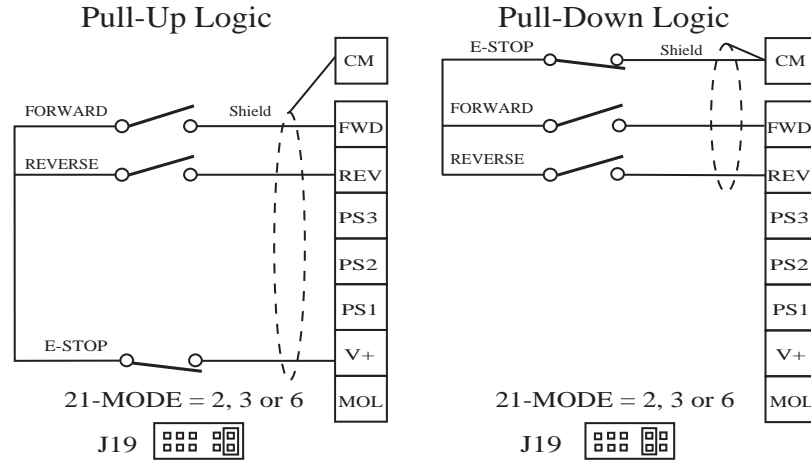

FIGURE 5.2

### 5.3 3-Wire Run/Stop Connections

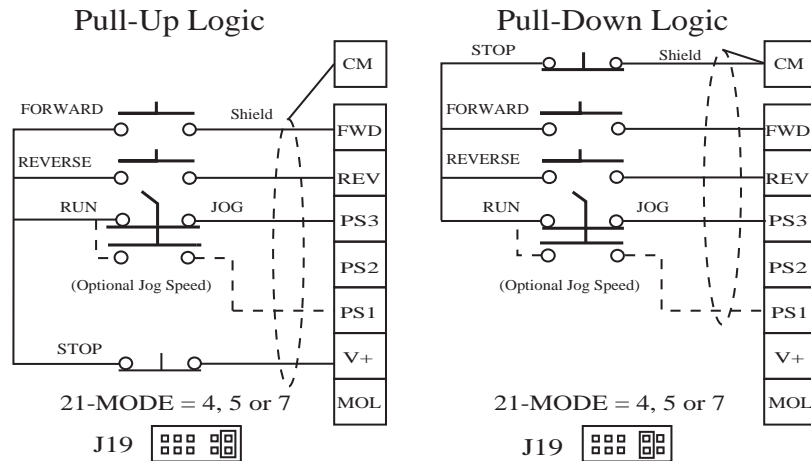

FIGURE 5.3

## 5.4 Analog Speed Input Connections

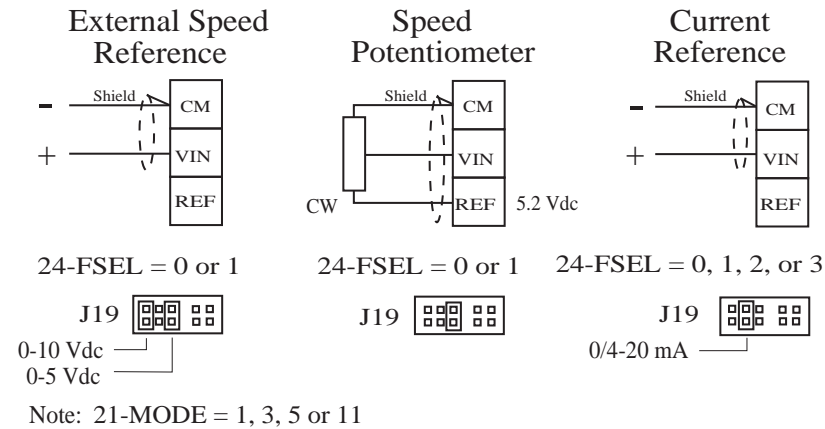
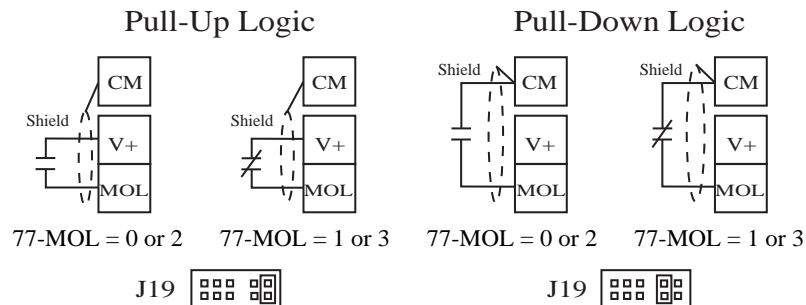

FIGURE 5.4

## 5.5 MOL Terminal Connections



Notes:  
 77-MOL = 0 or 1 used for F07 fault trip  
 77-MOL = 2 or 3 used for Coast-To-Stop

FIGURE 5.5

## 5.6 Optional Connections

### Preset Speed Selection

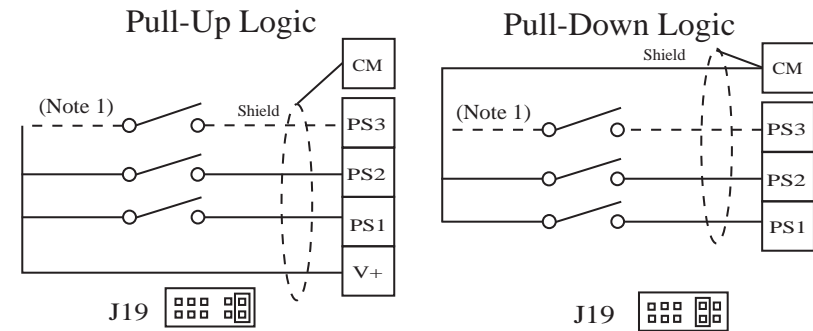

### EMOP Selection

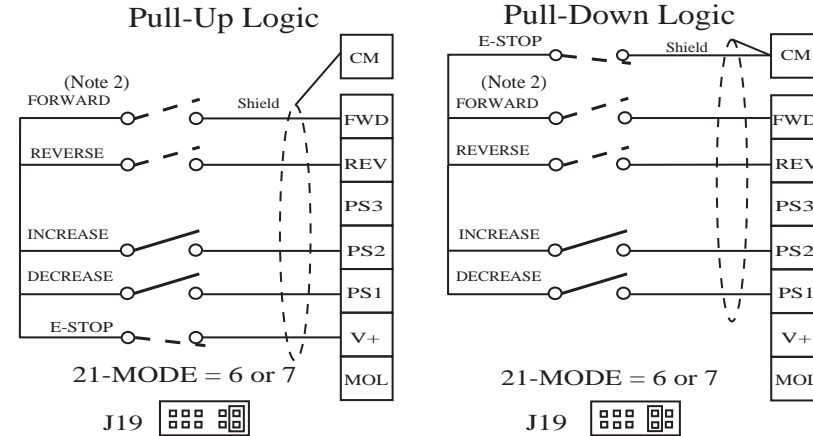

Notes:  
 1. See Section 2.11, Table 2.2  
 2. See Section 4.2, 21-MODE  
 21-MODE = 6 used for 2-Wire operation  
 21-MODE = 7 used for 3-Wire operation  
 3. See Section 4.2, 71-METER

FIGURE 5.6

### Analog Meter

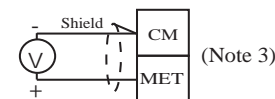

## SECTION 6 TROUBLESHOOTING

**WARNING**  
**DISCONNECT ELECTRICAL SUPPLY BEFORE SERVICING THE**  
**ELECTRICAL SYSTEM.**  
**AVERTISSIMENT**  
**COUPER L'ALIMENTATION AVANT D'ENRERENORE LE DEPANNAGE**  
**DU SYSTEME ELECTRIQUE.**

### 6.1 Special Indications

In addition to the standard operation and programming displays several special displays may appear:



FIGURE 6.1

Line Start Lockout. See 82-START in Section 4.2.

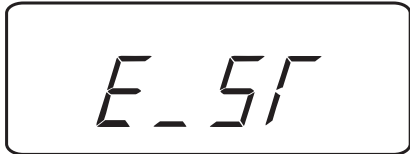

FIGURE 6.2

Emergency Stop. See 82-START in Section 4.2.



FIGURE 6.3

Low Voltage. AC line voltage is too low.

### 6.2 Fault Trip Indications

In the event of a fault trip, the STATUS indicator will begin to blink red (See Section 3.6) and the display will show the fault code as shown in Figure 6.4.



FIGURE 6.4

Pressing the UP arrow before the fault is reset will display the status of the drive at the time of the fault as shown in Figure 6.5. Note that more than one annunciator may be displayed to better define the cause of the fault. Additional information concerning the drive status at the time of the fault is available by pressing the PRG key and viewing parameters 12 through 17.



FIGURE 6.5

### 6.3 Resetting a Fault

Faults can be reset in any one of four (4) ways:

- A. Pressing the STOP key on the keypad (if present).
- B. Activating and then deactivating both the FWD and REV terminals simultaneously.
- C. Removing and restoring AC power.
- D. Using the automatic restart function 68-NRST, see Section 4.2.

## 6.4 Fault Codes

FAULT	CAUSE	REMEDY
F01	Computer Malfunction	1. Reset the drive using the stop key for longer than 1 second. 2. If the problem persists, consult the factory.
F02	Parameter Block Fault	1. Restore all parameters to factory settings by entering 81-PROG = 1. 2. If the problem persists, consult the factory.
F03	Bus Current Measurement Fault	1. Reset the fault by pressing the stop key. 2. If the problem persists, consult the factory.
F04	Power Supply Overload	Check for excessive loading on control terminals REF and V+. (See Section 2.11)
F05	No DC Bus Voltage	1. Check for proper source voltage. 2. Check for DB component or output transistor failure. 3. Check for shorted DC bus.
F06	Output Short Circuit	1. Check motor wiring. 2. Reduce 52-BOOST 3. Extend 42-ACC1 accel ramp
F07	External Fault Mechanism (i.e. Motor Overload Relay) tripped	1. Check motor temperature. 2. Verify the sizing of MOL.
F10	Auto-Restart (68-NRST) number exceeded	1. Check the fault log (07-FLT3, 08-FLT2, and 09-FLT1). 2. Institute corrective action for those faults. <b>NOTE: RESETTING THIS FAULT MAY CAUSE INSTANT STARTING. ENSURE THAT DOING SO WILL NOT CAUSE HARM TO PERSONNEL OR DAMAGE TO EQUIPMENT.</b>
F11	Ground Fault	1. Check motor wiring. 2. Check for and remove any capacitive load.

FAULT	CAUSE	REMEDY
F13	Overvoltage on DC Bus	1. Verify line voltage. 2. Excessive regenerative load. 3. Increase deceleration time. 4. Reduce preset regenerative current limit value.
F16	Acceleration Overcurrent	1. Increase acceleration ramp time. 2. Check motor wiring for short circuit. 3. Check for "normal" operation with motor disconnected
F17	Deceleration Overcurrent	1. Increase deceleration ramp time. 2. Reduce preset regenerative current limit value.
F18	Running Overcurrent	1. Locate cause of mechanical overload on the motor.
F19	Heatsink Over Temperature	1. Check for excessive overload 2. Verify the proper sizing of the drive for the application. 3. Locate the drive in a cooler location, out of direct sunlight
F20	Timed Overload	1. Check programming of 67-TOL. 2. Check for overload on the motor.

NOTES: 1. Faults **F01-F11** are checked during the power-up sequence.

2. **F02** is also checked during programming.

3. Faults **F11-F20** will be reset if the Auto-Restart function is selected (See 68-NRST).



## 6.5 Troubleshooting

PROBLEM	CHECK POINT	CORRECTIVE ACTION
<b>Motor is not running</b>	Incorrect wiring	Check all power and control wiring.
	External frequency command (if used)	1. Verify that the external frequency control signal is properly connected. 2. Verify the integrity of the frequency control potentiometer.
	Programming selections	Verify that the proper programming selections have been made for the application.
	Fault	1. Verify that the inverter has not shutdown due to a fault condition. 2. Consult Section 6.4.
	Motor stall	1. Release any overload on the motor. 2. Verify that adequate torque boost is available.
<b>Motor Speed Fluctuation</b>	Loose terminal connection	1. Stop the inverter, turn off power, & tighten all terminal screws. 2. Check for tightness of all connections within the drive.
	Frequency control pot erratic	Replace frequency control potentiometer.
<b>Motor Speed Too High or Too Low</b>	Frequency profile	Verify that the setting of 31-FMIN, 32-FMAX, & 53-FKNEE are correct for the motor specification and application.
	Frequency control signal	Verify the input signal level.
	Motor nameplate specifications	Verify that the motor selection is proper for the application.

## SECTION 7 APPENDIX

### 7.1 Hassle Free Warranty

The driving force at TB Wood's is customer service, including dealing with unforeseen problems without creating new ones! TB Wood's takes the extra step to ensure that ANY problem that occurs to its electronic products is dealt with swiftly and with no hassles to you. The Hassle Free Warranty removes the "burden of guilt" and promises to quickly replace any failed product.

**TB Wood's Incorporated warrants its electronic controls to be free of defects in parts or workmanship for a period of two (2) years from the date of manufacture. If a TB Wood's product fails for any reason, excluding physical abuse or repeated failure, within the warranty period, TB Wood's will promptly replace the product. TB Wood's Incorporated shall not in any event be liable for any incidental or consequential damages, secondary charges, expenses for installing or disconnecting, or losses to persons or property resulting from any failure of the product.**

## 7.2 E-trAC® XFC Series Options

Each of the following options connects to the J22 connector of the E-trAC®. (See Figure 2.8 to locate J22) and allow communication distances of up to 300 feet. Each option package includes a 10 foot, coiled connection cable for easy interfacing to the E-trAC®.

### **XRK01 - Remote Keypad Unit**

The XRK01 - Remote Keypad Unit (RKU) is a portable, hand-held accessory. When connected to an E-trAC® XFC Series, it will function in parallel with an existing keypad or allow a chassis model to be controlled and programmed. The RKU is powered by a 9 volt alkaline battery (supplied) or an optional AC adapter (PA24DC). Auto Power Down and backlight control features conserve battery life by automatically turning the RKU off after a specified time period and allowing selected use of the display backlight.

### **XPM01 - Program Memory Unit**

The XPM01 - Program Memory Unit (PMU) is another portable, hand-held accessory. When connected to an E-trAC® XFC Series with software revision 13.1 or greater, it allows operation and programming as does the RKU. In addition, it allows up to ten (10) different parameter sets to be stored internally. Any one can be downloaded to the inverter's active memory or customer parameter set. Uploading parameter sets from an inverter to a PMU memory location is also possible. The PMU is powered by a 9 volt alkaline battery or the AC adapter (both supplied). Auto Power Down and backlight control features conserve battery life by automatically turning the PMU off after a specified time period and allowing selected use of the display backlight.

### **XRP01 - Remote Panel Keypad**

The XRP01 Remote Panel Keypad is a NEMA 4 rated, panel mountable accessory. When properly installed, the XRP01 seals into the host enclosure assuring the NEMA 4 integrity is preserved. When connected to an E-trAC® XFC Series, it will function in parallel with an existing keypad or allow a chassis model to be controlled and programmed. The XRP01 is self-powered with the 3 & 5HP models and can be powered by an optional external AC adapter (PA24DC) or a customer supplied +24VDC source.

### **XRP02 - Remote Panel Programmer**

The XRP02 Remote Panel Programmer is a NEMA 4 rated, panel mountable accessory. When properly installed, the XRP02 seals into the host enclosure assuring the NEMA 4 integrity is preserved. When connected to an E-trAC® XFC Series with software revision 13.1 or greater, it allows operation and programming as does the XRP01. In addition, it allows up to ten (10) different parameter sets to be stored internally. Any one can be downloaded to the inverter's active memory or customer parameter set. Uploading parameter sets from an inverter to an onboard memory location is also possible. The XRP02 is self-powered with the 3 & 5HP models and can be powered by an optional external AC adapter (PA24DC) or a customer supplied +24VDC source.





**TB Wood's**

---

## **TB Wood's Incorporated**

<http://www.tbwoods.com>

**440 North Fifth Avenue**

**Chambersburg, Pennsylvania 17201-1778**

**Telephone: 800-789-6637 or 888-TBWOODS**

**Direct Dial (Sales) 717-267-2900**

**FAX: 717-264-6420**

### **T. B. Wood's Canada Ltd.**

750 Douro Street  
Stratford, Ontario, Canada N5A 6V6  
Telephone: 519-271-5380  
FAX: 519-271-3094

### **TB Wood's (México) S.A. de C.V.**

Oriente 237 No. 171  
Colonia Agrícola Oriental  
08500 México, D.F.  
México  
Telephone: 5-558-16-20 • FAX: 5-756-06-74

### **Plant Engineering Consultants**

(Wholly owned subsidiary)

521 Airport Road  
Chattanooga, Tennessee 37421  
Telephone: 800-437-3311 or 423-892-7654 • FAX: 423-894-0495

---

## **Distribution Centers**

### **ATLANTA**

700 Distribution Drive  
Atlanta, Georgia 30336  
Telephone: 800-789-6637 • FAX: 717-264-6420

### **CHICAGO**

1900 Touhy Avenue  
Elk Grove Village, Illinois 60007  
Telephone: 847-439-3788 • FAX: 847-439-0478

### **DALLAS**

1151 Empire Central  
Dallas, Texas 75247  
Telephone: 214-637-0850 • FAX: 214-637-0867

### **EDMONTON**

9779-45th Avenue  
Edmonton, Alberta, Canada T6E 5V8  
Telephone: 403-439-7979 • FAX: 403-439-7661

### **LOS ANGELES**

325 West 17th Street  
Los Angeles, California 90015  
Telephone or FAX: 800-451-1110

### **MONTREAL**

1073 Begin Street  
Ville St. Laurent  
Montreal, Quebec, Canada H4R 1V8  
Telephone: 514-332-4812 • FAX: 514-332-6842

### **PORTLAND**

2950 Northwest 29th Ave.  
Portland, Oregon 97210  
Telephone or FAX: 800-451-1110

---

## **Other Wood's Locations**

**Mt. Pleasant, MI • San Marcos, TX • Trenton, TN**