

F9 - 3U CompactPCI PentiumM SBC

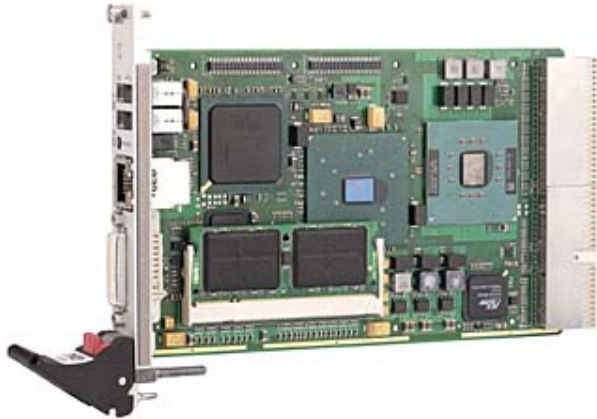

- ◆ **Pentium M (LV) up to 1.8 GHz**
- ◆ **Celeron M (ULV) 600 MHz**
- ◆ **1-slot 32-bit CompactPCI system master**
- ◆ **1 GB DDR RAM (SO-DIMM), CompactFlash**
- ◆ **Graphics controller / DVI-I (front)**
- ◆ **Gigabit Ethernet (front)**
- ◆ **Dual USB 2.0 (front)**
- ◆ **COM 1, IDE, 2 USB, keyboard/mouse via rear I/O**

Equipped with either the Intel (LV) Pentium M (Banias, Dothan) or the Celeron M processor, the 3U single-board computer is a versatile 4HP/3U (single size Eurocard) CompactPCI board, designed especially for systems which require low power consumption. Available either with the 1.8-GHz Pentium M Dothan745, or the 1.4-GHz low-voltage Pentium M Dothan, or the 1.6-GHz Pentium M Banias, or the 1.1-GHz low voltage Pentium M Banias, or a 600-MHz Celeron M processor and up to 1 GB RAM, the F9 covers a wide range of industrial applications.

The DVI-I video interface allows for attachment of both advanced (digital) and legacy (analog) flat panel

displays and CRT monitors (D-Sub connector optional). The F9 is also equipped with a Gigabit Ethernet controller. The onboard CompactFlash socket allows for utilization of a CompactFlash card or an IBM Microdrive. A local expansion interface connector may be used to directly attach a companion I/O board, which can carry in addition a 2.5" hard-disk drive. As an option, rear I/O across the J2/P2 connector is available.

Equipped with a PCI-bridge chip, the F9 offers a full CompactPCI interface for reliable system expansion. Last but not least, the F9's Phoenix BIOS was especially designed for embedded system applications.

Technical Data

CompactPCI Bus

- 3U CompactPCI CPU board PICMG Spec. 2.0 R3.0 compliant
- 32-bit CompactPCI system slot functionality with 7 possible external loads
- PCI-to-PCI bridge
- Single-slot solution
- V(I/O): +5V (+3.3V on request)

CPU

- Intel Celeron M (ULV) or Pentium M Banias or Pentium M Dothan
- 600MHz..1.8GHz

Chipset

- Intel i855 chip set consisting of:
 - 82855GME Graphics/Memory Controller Hub (GMCH)
 - 82801D I/O Controller Hub (ICH4)
 - 82802 Firmware Hub (FWH)

Graphics

- Integrated VGA graphics controller
 - Connection at front panel or via rear I/O / transition module
 - Maximum resolution: 2048 x 1536, 16M colors
 - PanelLink Digital technology

Memory

- CPU L2 Cache
 - Celeron M: 512KB
 - Pentium M Banias: 1MB
 - Pentium M Dothan: 2MB
- Up to 1 GB DRAM
 - One 200-pin SO-DIMM socket for DDR SDRAM modules
 - PC2100/2700
 - DDR266/333-SDRAM
- CompactFlash interface
 - Type I and Type II
 - True IDE
 - For CFA ATA memory card or Microdrive

Interfaces

- 10/100/1000Mbps/s Gigabit Ethernet controller
 - RJ45 interface at front panel or via rear I/O transition module
 - Two display LEDs in RJ45 connector to signal LAN Link and Activity status
 - Supports network boot
- USB 2.0 interfaces
 - Conforming to Open HCI 1.0a
 - Two ports via Type A connectors at front panel
 - Two ports via rear I/O transition module

- Data throughput up to 480Mbps/s

Mass Storage

- Fast IDE ports
 - One IDE hard-disk/CD-ROM port via ribbon cable connector Ultra ATA/100; for connection to mezzanine expansion board with onboard hard disk drive or external device (Secondary IDE)
 - One IDE port for local CompactFlash (Secondary IDE)
 - One IDE port via rear I/O transition module (Primary IDE)

Rear I/O Options

- Via rear I/O transition module
- Primary IDE
- Two USB 2.0 ports
- Keyboard/mouse
- COM1 (TTL level)
- Gigabit Ethernet (option)
- VGA analog video (option)

Further Options - Only on Request

- F9 for 64-bit CompactPCI systems only in combination with special rear I/O and extension board versions
- Extension possibility for F9 to 6U height
- Second Ethernet port via special I/O extension board
- More different legacy I/O combinations via special I/O extension board
- One-piece 3U/8TE front panel for F9 in combination with different I/O extension boards

Electrical Specifications

- Supply voltage/power consumption:
 - +5V (4.85V..5.25V), 5.8A max. @ 1.6GHz (0.96A WinXP idle mode)
 - +3.3V (3.2V..3.47V), 3.5A max. @ 1.6GHz (2.1A WinXP idle mode)
- MTBF: tbd. @ 50°C

Mechanical Specifications

- Dimensions: conforming to CompactPCI specification for 3U boards
- Weight: tbd.

Environmental Specifications

- Temperature range (operation):
 - 0..+60°C
 - Industrial temperature range on request
 - Airflow: min. 10m³/h
- Temperature range (storage): -40..+85°C
- Relative humidity (operation): max. 95% non-condensing
- Relative humidity (storage): max. 95% non-condensing

Technical Data

- Altitude: -300m to + 3,000m
- Shock: 15g/11ms
- Bump: 10g/16ms
- Vibration (sinusoidal): 2g/10..150Hz

Safety

- PCB manufactured with a flammability rating of 94V-0 by UL recognized manufacturers

EMC

- Tested according to EN 55022 / 1999-05 (radio disturbance) and EN 55024 / 1999-05 (immunity) with regard to CE conformity

Software Support

- Phoenix BIOS, single or dual FWH (8/16-Mbit Flash Memory)

Diagram

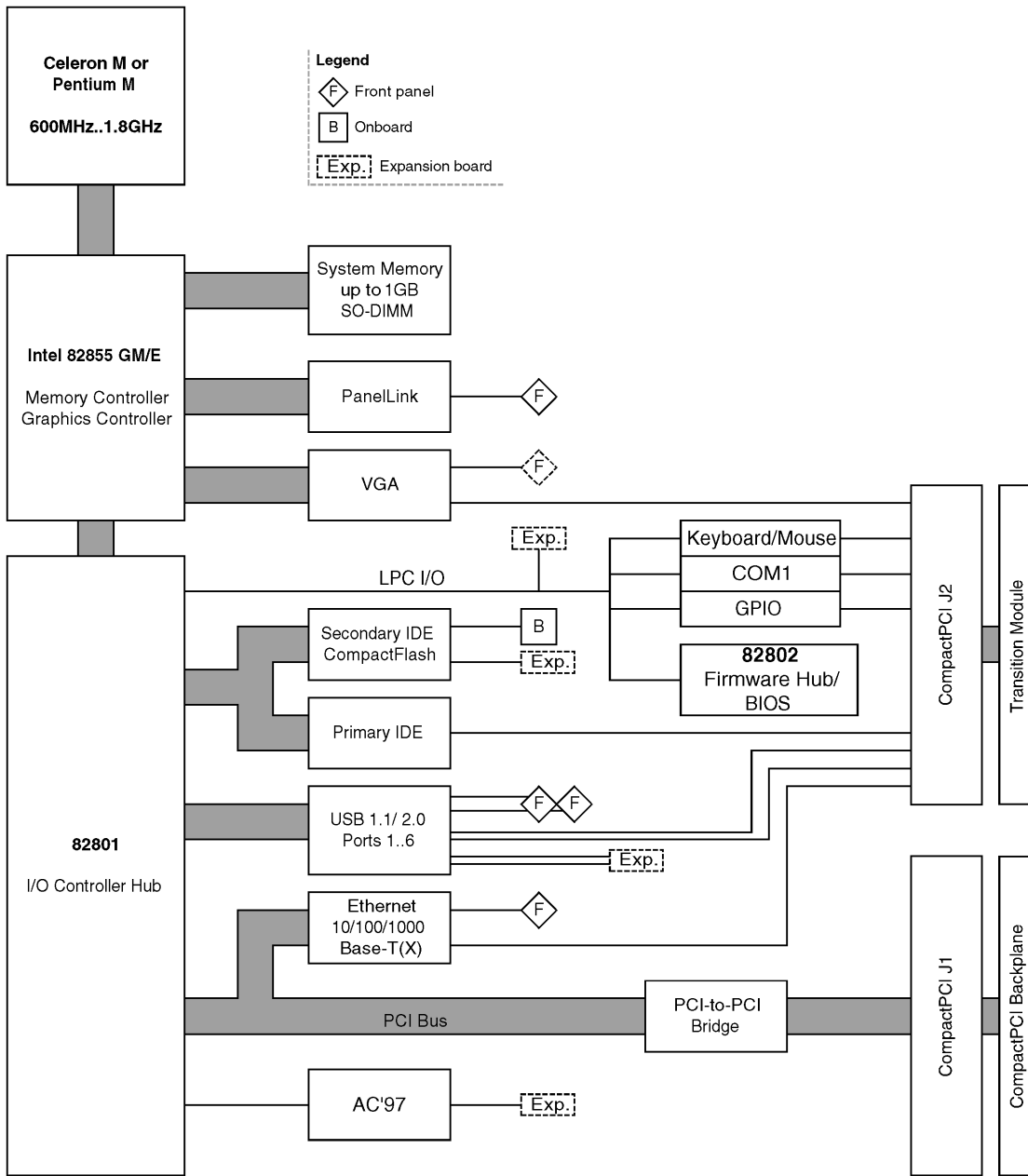

Related Products

Standard Hardware

02F009E00	F9E, 1-slot 3U I/O extension for F9 with PS/2 keyboard/mouse, USB, 1 COM, audio, prepared for 2.5" hard disk (replaces CompactFlash facility), mounting on top or bottom of F9, 0..+60°C
02F009-00	F9, 3U 4HP 32-bit CompactPCI system slot SBC with ULV Celeron M 600MHz (512KB L2 cache, 7W), SO-DIMM slot, CompactFlash slot, 1 Gigabit Ethernet (front), 2 USB 2.0 (front), CRT/LCD graphics (DVI-I front); operation temperature 0..+60°C
02F009-01	F9, 3U 4HP 32-bit CompactPCI system slot SBC with LV Pentium M 1.4GHz (Dothan 738 with 2MB L2 cache, 10W), SO-DIMM slot, CompactFlash slot, 1 Gigabit Ethernet (front), 2 USB 2.0 (front), CRT/LCD graphics (DVI-I front); operation temperature tbd.

F9 offers different combination possibilities with I/O extension and rear I/O cards.

Please refer to our 3U CompactPCI compare chart for a selection of further single-board computers with different processors and on-board functionality.

Systems & Card Cages

Disk drives for basic systems are delivered as requested. Different rack sizes, power supplies and backplanes on request.

Accessories

05A000-10	Keyboard/mouse Y-cable 0.1m, 6-pin Mini DIN plug to two 6-pin Mini DIN receptacles
05F007-02	DVI-to-VGA cable, DVI plug to 15-pin HD-Sub plug, 2m, -40..+85°C
05F007-03	Adapter, DVI analog plug to VGA 15-pin HD-Sub receptacle, -20..+85°C
0501-0001	DVI-I to DVI-D and VGA Y-adapter cable (for example for D4, F7/N, F8, F9, P17)

You can download the data sheet for hard disk 0710-0012 from MEN's website.

0710-0009	IDE hard disk 2.5", 9.5mm, 20GB; for mounting on-board (harddisk mounting kit may be additionally required)
0710-0012	Industrial IDE hard disk 2,5", 40GB, 24 hours/7 days, 0..+60°C; for on-board mounting (hard disk mounting kit may be required additionally)
0713-0001	CompactPCI 1-slot 3U I/O midplane
0751-0006	CompactFlash card, 512MB, Type I, 0..+60°C
0751-0007	CompactFlash card, 512MB, Type I, -40..+85°C

Related Products

0751-0008	CompactFlash card, 64MB, Type I, 0..+60°C
0751-0009	CompactFlash card, 128MB, Type I, 0..+60°C
0751-0012	CompactFlash card, 256MB, Type I, 0..+60°C
0751-0013	Compact Flash card, 64MB, -40..+85°C
0751-0014	Compact Flash card, 128MB, -40..+85°C
0751-0018	CompactFlash card, 256MB, Type I, -40..+85°C
0752-0176	512 MB DDRAM 0..+60°C for 02F009-00
0752-0177	1 GB DDRAM 0..+60°C for 02F009-00
0752-0178	512 MB DDRAM 0..+60°C for 02F009-01
0752-0179	1 GB DDRAM 0..+60°C for 02F009-01
08F009R00	F9R, 1-slot 3U rear I/O transition module for F9 for 32-bit PCI systems; with primary IDE, USB ports 3 and 4, PS/2 keyboard/mouse, COM1 (TTL level); optional: VGA analog video and Gigabit Ethernet, 0..+60°C
08SA01-00	Serial interface adapter, RS232, not optically isolated, 0..+60°C
08SA02-00	Serial interface adapter, RS422/485, half duplex, optically isolated, 0..+60°C
08SA02-01	Serial interface adapter, RS422/485, full duplex, optically isolated, 0..+60°C
08SA02-07	Serial interface adapter, RS422/485, full duplex, optically isolated, temperature range: -40..+85°C
08SA03-00	Serial interface adapter, RS232, optically isolated, 0..+60°C
08SA03-01	Serial interface adapter, RS232, optically isolated, -40..+85°C
08SA04-00	Serial interface adapter, TTY, optically isolated, 0..+60°C

For more functions realized with SA adapters, see the listing on MEN's website. You can also view our SA adapter compare chart for a quick overview of different functions. Please contact sales to make sure that these SA adapters can be used in the board configuration you are looking for.

Software

This MEN board is designed to work in a Microsoft Windows environment. For additional Windows driver packages provided or recommended by MEN please refer to the ordering numbers below.

VxWorks software for this MEN board is available from WindRiver Systems. For VxWorks BSP and driver support provided by MEN please refer to the ordering numbers below.

Related Products

This board is an MEN product running Linux. For Linux BSP and driver support provided by MEN please refer to the ordering numbers below.

To use MDIS4 low-level drivers, you also need one of the MDIS4 system packages available for Windows, Linux, VxWorks, QNX, RTX or OS-9 (MDIS4 = MEN Driver Interface System).

Documentation

20ABMX-00	Phoenix BIOS user manual
20APPN001	Application Note: Using MEN +5V CompactPCI Boards with +3.3V V(I/O)

For the most up-to-date ordering information and direct links to other data sheets and downloads, see the F9 online data sheet under www.men.de. --> [Click here!](#)

Germany

MEN Mikro Elektronik GmbH
Neuwieder Straße 5-7
90411 Nuremberg
Phone +49-911-99 33 5-0
Fax +49-911-99 33 5-901
E-mail info@men.de
www.men.de

France

MEN Mikro Elektronik SA
18, rue René Cassin
ZA de la Châtelaine
74240 Gaillard
Phone +33 (0) 450-955-312
Fax +33 (0) 450-955-211
E-mail info@men-france.fr
www.men-france.fr

UK

MEN Micro Ltd
Whitehall, 75 School Lane
Hartford, Northwich
Cheshire UK, CW8 1PF
Phone +44 (0) 1477-549-185
Fax +44 (0) 1477-549-178
E-mail info@menmicro.co.uk
www.menmicro.co.uk

USA

MEN Micro, Inc.
PO Box 4160
Lago Vista, TX 78645-4160
Phone (512) 267-8883
Fax (512) 267-8803
E-mail sales@menmicro.com
www.menmicro.com

The date of issue stated in this data sheet refers to the Technical Data only. Changes in ordering information given herein do not affect the date of issue. All brand or product names are trademarks or registered trademarks of their respective holders.

Information in this document has been carefully checked and is believed to be accurate as of the date of publication; however, no responsibility is assumed for inaccuracies. MEN Mikro Elektronik accepts no liability for consequential or incidental damages arising from the use of its products and reserves the right to make changes on the products herein without notice to improve reliability, function or design. MEN Mikro Elektronik does not assume any liability arising out of the application or use of the products described in this document.

The products of MEN Mikro Elektronik are not suited for use in nuclear reactors and for application in medical appliances used for therapeutical purposes. Application of MEN's products in such plants is only possible after the user has precisely specified the operation environment and after MEN Mikro Elektronik has consequently adapted and released the product.

Copyright © 2004 MEN Mikro Elektronik GmbH. All rights reserved.