

- 500 mA continuous source only or source/sink current (fan cooled)
- 64 bits of high current outputs
- ± 3.5 A peak output current (100 ms, 10 percent DC)
- Output transient protected
- Thermal shutdown protection
- High breakdown voltage (35 V minimum)
- 8-, 16-, or 32-bit transfers
- Built-in-Test logic for fault isolation
- Software compatible with VMIVME-2120
- Compatible with Intelligent I/O Controllers
- High reliability DIN-type output connectors
- Outputs are jumper-selectable for source/high-Z or source/sink operations
- Double Eurocard form factor
- Front panel Fail LED

FUNCTIONAL CHARACTERISTICS

Compatibility: VMEbus specification-compatible double height form factor

Output Connector Type: Dual 64-pin connectors - DIN 41612

Output Organization: Eight output ports, eight bits wide. Addressable to any address within short supervisory or short nonprivileged I/O map. Control and Status Register (CSR) address is independently selectable. Each byte can be jumper selected for source/High-Z operations or source/sink operations.

Address Modifier Codes: Jumper-selectable for short supervisory or short nonprivileged I/O access. Factory configured for short supervisory I/O access.

Addressing Scheme: Eight ports individually addressable on 8-, 16-, or 32-bit boundaries. The separate board address decoder for the Control and Status Register allows addresses for hardware control to be grouped for improved software efficiency.

Built-in-Test: This product supports off-line and real-time fault detection and isolation. The off-line mode is enabled by executing a write to the CSR to set the Test Mode Bit. All outputs are OFF with the Test Mode enabled.

Fail LED: A Fail LED is provided that is illuminated at power up and extinguished under program control upon a successful diagnostic execution.

ELECTRICAL CHARACTERISTICS¹

Output Breakdown Voltage: $V_S + 2.0$ V

Output Current: 500 mA continuous source and/or sink

Peak Output Current: 3.5 A maximum (100 ms, 10 percent DC)

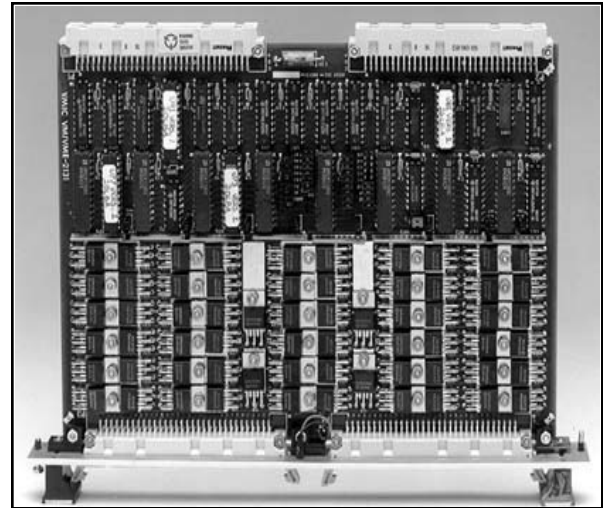

Output Circuit Protection: Thermal shutdown protection

Output Leakage Current: 500 μ A over 0 to 33 V

Output Saturation Voltage: 2 V maximum at 2 A

Output Voltage Drop: 2 V maximum at 2 A and 31 V output

Output Driver Supply Voltage V_S : 8.0 to 33 V

Ordering Options							
April 28, 1998 800-012131-000 C	A	B	C	-	D	E	F
VMIVME-2131	-		0	-			
A = Manufacturing Option X = Letter Called Out by Customer 0 = Assigned by Manufacturing* 1 = Assigned by Manufacturing* 9 = Reserved B = Data Polarity 0 = Negative True 1 = Positive True C = 0 (Option reserved for future use) *An example of an order would be the following: VMIVME-2131-X10. The "X" would be assigned at the factory by manufacturing and would either be "010" or "110." The board functions identically, but parts within are of different types.							
Connector Data							
Compatible Cable Connector	Panduit No. 120-964-435E						
Strain Relief	Panduit No. 100-000-032						
PC Board Connector	Panduit No. 120-964-033A						
For Ordering Information, Call: 1-800-322-3616 or 1-256-880-0444 • FAX (256) 882-0859 E-mail: info@vmic.com Web Address: www.vmic.com Copyright © September 1995 by VMIC Specifications subject to change without notice.							

1. Additional specifications are provided on page 2.

PHYSICAL/ENVIRONMENTAL

Temperature Range: 0 to 55 °C, operating
-20 to 85 °C, storage

Relative Humidity Range: 20 to 80 percent,
noncondensing

Cooling: Forced convection

Power Requirements: +5 V at 5.1 A maximum

External power (8 to 35 V) must be supplied to each output driver used through the front panel connector. The no load supply current is 35 mA per driver.

MTBF: 373,400 hours (217F)

APPLICATIONS —

- Relay drivers
- Lamp drivers
- Solenoid drivers
- Hammer drivers
- Stepper motor drivers
- Triac drivers
- LED drivers
- High current, high-voltage drivers
- Fiber-optic LED drivers

POSITIVE/NEGATIVE TRUE ORDERING INFORMATION — This board supports a current source-only mode (the output presents a High-Z state or current source) and a current source/sink mode (the output either sources or sinks current). When configuring a positive true board in the current source-only mode, a logic zero input

from the VMEbus data lines will result in a High-Z output state while a logic one from the VMEbus data lines will source current to the output. For a negative true board, the opposite is true. The output will source current when a logic zero is written from the VMEbus data lines.

When configuring a positive true board in the current source/sink mode, a logic zero input from the VMEbus data lines will place a low voltage at the output and thus the board will sink current. Writing a logic one on the VMEbus data lines will place a high voltage at the output and the board will source current. For a negative true board, placing a logic zero out the VMEbus data lines will cause the output to source current, while placing a logic one onto the VMEbus data lines will cause the output to sink current.

TRADEMARKS

The VMIC logo is a registered trademark of VMIC. Other registered trademarks are the property of their respective owners.



systemerra computer GmbH • Kreuzberger Ring 22
D-65205 Wiesbaden • ☎ +49 (0) 611 9748 470
✉ info@systemerra.de • 🌐 www.systemerra.de

APPLICATION AND CONFIGURATION GUIDES — The following Application and Configuration Guides are available to assist the user in configuring systems based on VMIC's products:

Title	Document No.
Digital Input Board Application Guide	825-000000-000
Change-of-State Board Application Guide	825-000000-002
Digital I/O (with Built-in-Test) Product Line Description	825-000000-003
Synchro/Resolver (Built-in-Test) Subsystem Configuration Guide	825-000000-004
Analog I/O Products (with Built-in-Test) Configuration Guide	825-000000-005
Connector and I/O Cable Application Guide	825-000000-006
Data Acquisition Noise Reduction Application Guide	825-000000-026

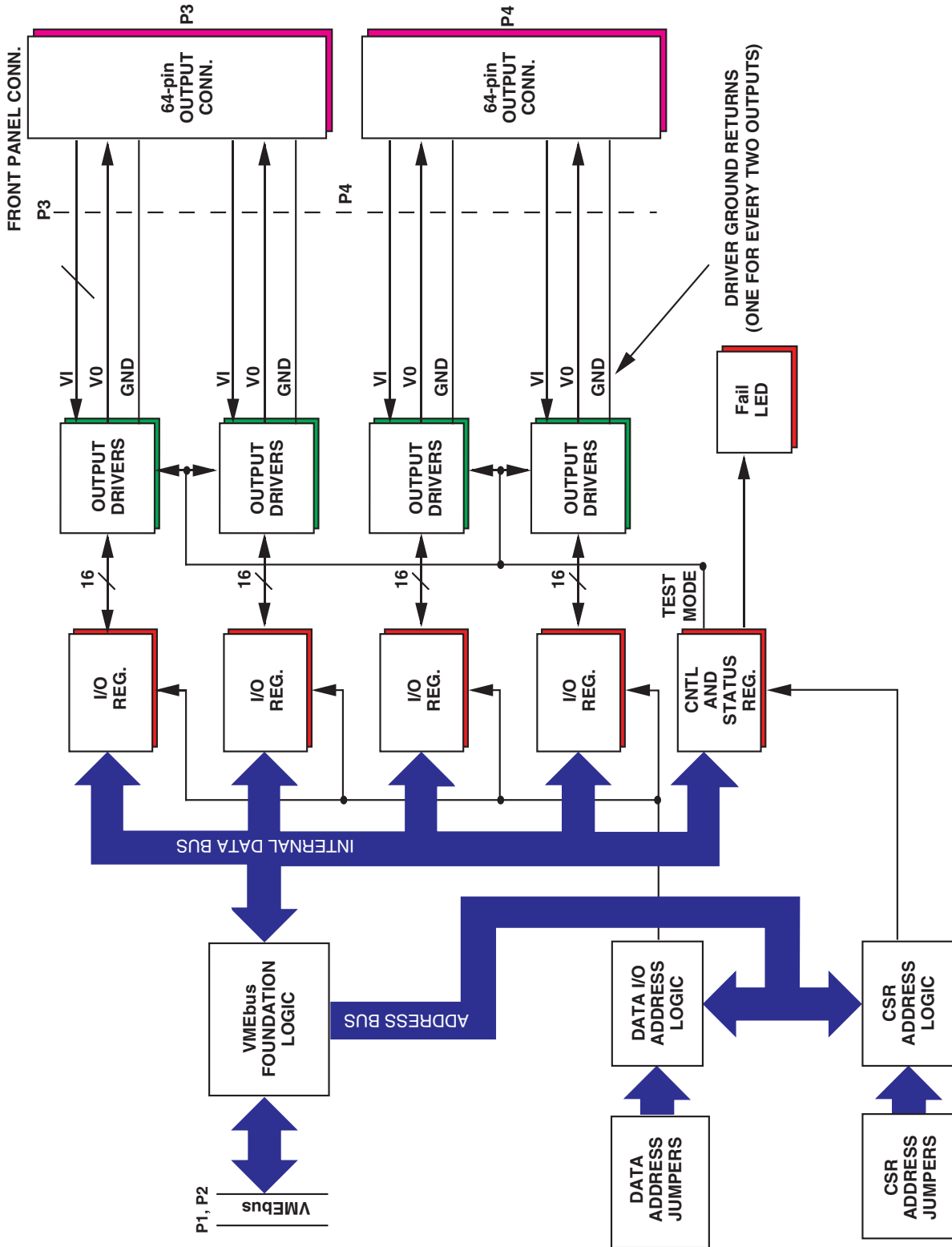

Figure 1. VMIVME-2131 Functional Block Diagram

VMIVME-2131 OUTPUT DRIVER STAGE

UDN-2935Z HIGH-CURRENT BIPOLAR HALF-BRIDGE MOTOR DRIVER

FEATURES

- 3.5 A Peak Output
- 35 V Output Breakdown
- Output Transient Suppression
- TTL, CMOS, PMOS, NMOS Compatible Inputs
- High-Speed Chopper (to 100 kHz)
- Low Standby Current (10 mA)
- To 220-Style Package
- Internal Thermal Shutdown

SIMPLIFIED DIAGRAM

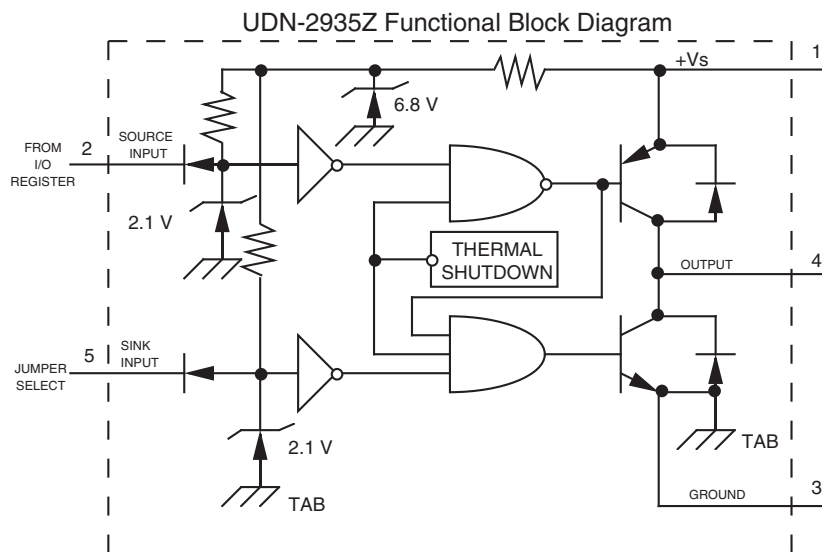
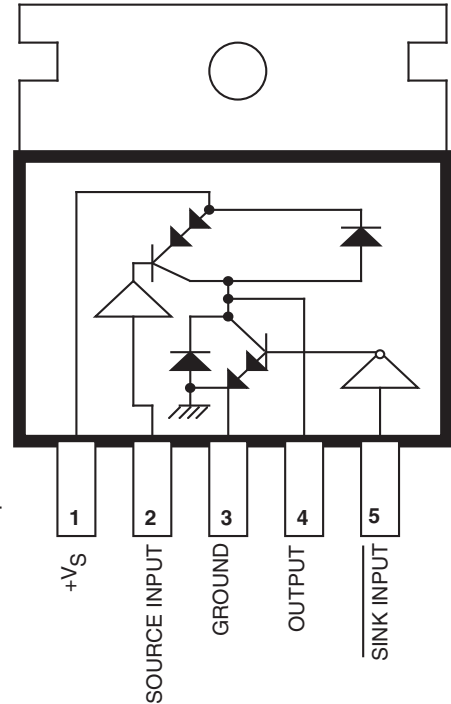

LOGIC TRUTH TABLE

DATA REGISTER INPUT, V_2	JUMPER SELECT INPUT, V_5	OUTPUT V_4
LOW	LOW	HIGH
LOW	HIGH	HIGH
HIGH	LOW	LOW
HIGH	HIGH	HIGH-Z