

## I25FB - 2.5" High Performance IDE Flash Disk

The Adtron™ Flashpak™ model I25FB delivers high performance and durability with an industry standard ATA/ATAPI interface and UDMA-100 in a 2.5-inch IDE flash disk offering sustained read/write rates up to 80 MBytes/sec and capacities up to 56 GBytes. Designed with Adtron ArrayPro™ technology, the Adtron I25FB Flashpak disk performs under conditions of extended temperatures, high shock and vibration and rapid temperature gradients.

The I25FB Flashpak disk uses Adtron SmartStorage™ architecture to deliver exceptional sustained read/write performances and capacities to meet your demanding application needs. Adtron I25FB Flashpak flash disks are low profile, 2.5-inch flash disks that provide the same storage functions found in hard disk drives, plus the enhanced operating reliability of long life mean time before failure (MTBF) and rugged durability. The industry PATA interface simplifies the integration of flash storage into almost any computing platform and operating environment.



I25FB

## Flashpak™ Data Storage

### Adtron Corporation

4415 E. Cotton Center Blvd., Suite 100  
Phoenix, AZ 85040  
Tel: (602) 735-0300 • Fax: (602) 735-0359  
Email: [info@adtron.com](mailto:info@adtron.com)  
Web: <http://www.adtron.com>

Europe: Zurich, Switzerland  
Tel: +41-56-496-5640 • Fax: +41-56-496-5648  
Email: [europe@adtron.com](mailto:europe@adtron.com)

## CONTENTS

STANDARD FEATURES .....	1
OPTIONAL FEATURES .....	2
APPLICATIONS .....	2
SECURE ERASE FUNCTIONALITY .....	3
Adtron™ EraSure™ Technology .....	3
EraSure Clear .....	3
EraSure Sanitize .....	3
Commands and Codes.....	3
PHYSICAL CHARACTERISTICS .....	3
PERFORMANCE .....	3
RELIABILITY .....	4
ENVIRONMENTAL .....	4
RECOMMENDED OPERATING CONDITIONS.....	4
POWER REQUIREMENTS .....	4
IDE BUS DC CHARACTERISTICS .....	5
COMPLIANCE .....	5
PIN CONFIGURATION .....	6
Signal Connector Pinout.....	6
I25FB Connector Pinouts.....	6
CONFIGURATION DESCRIPTIONS .....	7
PACKAGE DIMENSIONS .....	8
PACKAGE DIMENSIONS - 1 EXPANDER .....	9
PACKAGE DIMENSIONS - 2 EXPANDER .....	10
PACKAGE DIMENSIONS - 3 EXPANDER .....	11
ORDERING INFORMATION .....	12

---

Trademarks are the property of their respective owners.  
The information contained in this document is subject to change without notice and does not represent or imply warranty, and no liability is assumed by Adtron Corp.

## STANDARD FEATURES

The Adtron™ I25FB Flashpak™ storage subsystem includes the following standard features:

<b>Form Factor</b>	2.5-inch
<b>Solid State</b>	All solid state technology, no moving parts
<b>Technology</b>	Adtron ArrayPro™ flash array processing
<b>Interface Standard</b>	ATA/ATAPI-5, including UDMA-100 compliant
<b>Mounting</b>	Hard disk drive industry standard, all orientations
<b>Connector</b>	Standard IDE 44-pin, 2mm connector and interface
<b>Transfer Modes</b>	PIO Modes 0-4, Multiword DMA Modes 0-2, and UDMA Modes 0-5 are currently supported
<b>Software Drivers</b>	No software drivers are required for full IDE disk support as a boot and data storage device
<b>Addressing</b>	48-bit Logical Block Addressing supported
<b>Sectors</b>	Standard 512 byte sectors
<b>Error Detection and Correction</b>	Reliability ensured by EDC and ECC defect management; ATA-compliant Self Monitoring, Analysis, and Reporting Technology (S.M.A.R.T), supporting thermal and vendor specific
<b>Firmware</b>	Field upgradable flash firmware prevents future obsolescence upgradable through an onboard serial port
<b>Input Voltage</b>	5VCC +/- 5%
<b>Adtron EraSure™ Technology</b>	Secure erase options include "clear"; and "sanitize" compliant with NISPOM DoD 52220.22-M, NSA-130-2, Air Force AFSSI-5020, Army AR380-19 and Navy NAVSO P-5239-26  <ul style="list-style-type: none"> <li>• LED indication for secure erase</li> <li>• Hardware or software initiation of secure erase function</li> <li>• Auto-resume after power interrupt</li> </ul>
<b>Onboard LED</b>	Idle, Busy, and Fault conditions
<b>Operating Temperatures</b>	Commercial operating temperature range from 0 to +70°C Industrial operating temperature range from -40°C to +85°C
<b>Warranty</b>	3 Years

Table 1 Standard Features

## OPTIONAL FEATURES

Customers may request the following optional features. Check with your Adtron representative for more information.

- Extended sustained read/write rates
- Non-standard capacity increments
- PCB conformal coating
- Remote LED capability
- Write protect option
- Password protect
- Adtron™ EraSure™ Zap technology for complete physical destruction

## APPLICATIONS

Below is a list of potential embedded applications in which the I25FB may be implemented:

- C4ISR defense applications
- Avionics
- Video streaming
- Instrumentation, test, and measurement
- Factory automation and robotics
- Ruggedized laptops
- Telecommunications switches
- Network routers

## SECURE ERASE FUNCTIONALITY

The task to secure data includes various levels of security and if the system is under threat of compromise, the data can be eliminated.

### Adtron™ EraSure™ Technology

Adtron EraSure technology manages the elimination of data from storage systems, and can be applied at two security levels, each with unique attributes of security, speed, and reuse after data elimination.

#### EraSure Clear

The Adtron EraSure "Clear" is the lowest level of erase security. The EraSure Clear procedure is a bulk erase function of the flash array, and eliminates data in all non-volatile memory. The I25FB Flashpak™ flash disk supports a clear process with a time frame less than 20 seconds.

#### EraSure Sanitize

The Adtron EraSure "Sanitize" is the sanitization procedure that enables multiple overwrites in a custom or preprogrammed pattern across the entire flash disk capacity. The I25FB Flashpak flash disk supports a sanitization rate up to 100 MB/sec, accomplished by the integration of Adtron ArrayPro™ and EraSure technologies. A preselected customized or preprogrammed sanitization procedure can be configured to run from an external trigger.

### Commands and Codes

EraSure technology operations are controlled by the Secure Erase Prepare (F3h) and Secure Erase Unit (F4h) commands found in the ATA Specification (Versions 3 - 7).

## PHYSICAL CHARACTERISTICS

Parameter	Value (Typ)
Height	8.8mm [.346"] - (512MB to 8GB) 14.4mm [.568"] - (12GB to 24GB) 20.5mm [.807"] - (28GB to 40GB) 26.6mm [1.046"] - (44GB to 56GB)
Depth	101.6mm [4.00"]
Width	69.9mm [2.750"]
Weight	Contact Adtron Sales

Table 2

## PERFORMANCE

Item	Performance			
	512MB - 8GB	12GB - 16GB	20GB - 24GB	28GB - 56GB
Start up times (Reset to Busy)	25 µs	25 µs	25 µs	25 µs
Start up times (Reset to Not Busy)	5 sec (max)	5 sec (max)	5 sec (max)	5 sec (max)
Read (Sustained)	20MB/sec	30 - 40MB/sec	50 - 60MB/sec	70 - 80MB/sec
Write (Sustained)	20MB/sec	30 - 40MB/sec	50 - 60MB/sec	70 - 80MB/sec
Read (Burst)	100MB/sec	100MB/sec	100MB/sec	100MB/sec
Write (Burst)	100MB/sec	100MB/sec	100MB/sec	100MB/sec

Table 3

## RELIABILITY

Item	Value
MTBF (Note 1)	250,000 hours
Bit Error Rate (BER)	< 1 non-recoverable error in 10 <sup>14</sup> bits read
Write Endurance per Sector	Minimum: 300,000 write/erase cycles Typical: > 1,000,000 write/erase cycles
Read Endurance	Unlimited
Data Retention at 25°C	> 10 years

Table 4

Note 1: Predicted by analysis performed per MIL-HDBK-217F, 30°C.

## ENVIRONMENTAL

Parameter	Unit	
Relative Humidity (Note 2)	5% to 95%, noncondensing	
Altitude (Note 3)	24,384m (80,000ft)	
Operating Environments	Operating Shock (SRS) (Note 4)	70g half-sine, 100-3000 Hz, 3X, 3 axes
	Operating Vibration-random (Note 5)	Helicopter: 2.9g rms, 3-500 Hz random, 3 axes Jet: 10g rms, 5-2000 Hz random, 3 axes Jet: 16.4g rms, 10-2000 Hz random, 3 axes

Table 5

Notes:

- 2 Testing in accordance with MIL-STD-810F, Method 507.4
- 3 Testing in accordance with MIL-STD-810F, Method 500.4 Procedure 1
- 4 Testing in accordance with MIL-STD-810F, Method 516.5 Procedure 1
- 5 Testing in accordance with MIL-STD-810F, Method 514.5 Procedure IV (modified)

## RECOMMENDED OPERATING CONDITIONS

Parameter	Symbol	Min	Typ	Max	Unit
Vcc	Vcc	4.75	5	5.25	V
Commerical operating temperature	Ta	0	25	70	°C
Industrial operating temperature	Ta	-40	--	85	°C

Table 6

## POWER REQUIREMENTS

Parameter (Note 6)	Value (Typical)	Unit	Value (Typical)	Unit
Sustained Read	.400	A	2	W
Sustained Write	.400	A	2	W
Startup	1.000	A	--	--
Idle	.350	A	1.75	W
Clear (Secure Erase Function)	.400	A	2	W
Sanitize (Secure Erase Function)	.400	A	2	W

Table 7

Note 6: At 8 GByte capacity

**IDE BUS DC CHARACTERISTICS**

Parameter Symbol	Parameter Description	Test Conditions	Min	Max	Unit
ViH	Voltage Input High		2.0	Vcc + 0.5	V
ViL	Voltage Input Low		Vss -0.5	0.8	V
VoH	Voltage Output High	IOH = -4mA	2.4	VCC	V
VoL (Note 7)	Voltage Output Low	IOL = 4mA	VSS	0.5	V
Vcc	Vcc		-0.3	+6.0	V
Vin, Vout	All input/output voltages		-0.3	Vcc +0.3	V
C	Capacitance			20.0	pF

Table 8

Note 7: -DASP IOL is 12mA as per ATA/ATAPI-6 specification

**COMPLIANCE**

EMI	CE, FCC
Safety	CE, UL

Table 9

## PIN CONFIGURATION

### Signal Connector Pinout

Pin #	Signal	Pin #	Signal
A	J_-Slave	B	JP_GNDB
C	JP_GNDC	D	J_CSEL_-EN
1	-RESET	2	GND
3	DB7	4	DB8
5	DB6	6	DB9
7	DB5	8	DB10
9	DB4	10	DB11
11	DB3	12	DB12
13	DB2	14	DB13
15	DB1	15	DB14
17	DB0	18	DB15
19	GND	20	[KEY]
21	DMARQ	22	GND
23	-DIOW	24	GND
25	-DIOR	26	GND
27	IORDY	28	CSEL
29	-DMACK	30	GND
31	INTRQ	32	-IOCS16
33	DA1	34	-PDIAG
35	DA0	36	DA2
37	-CS0	38	-CS1
39	-DASP	40	GND
41	+5V	42	+5V
43	GND	44	N/C

Table 10 Signal Connector Pinout

### I25FB Connector Pinouts

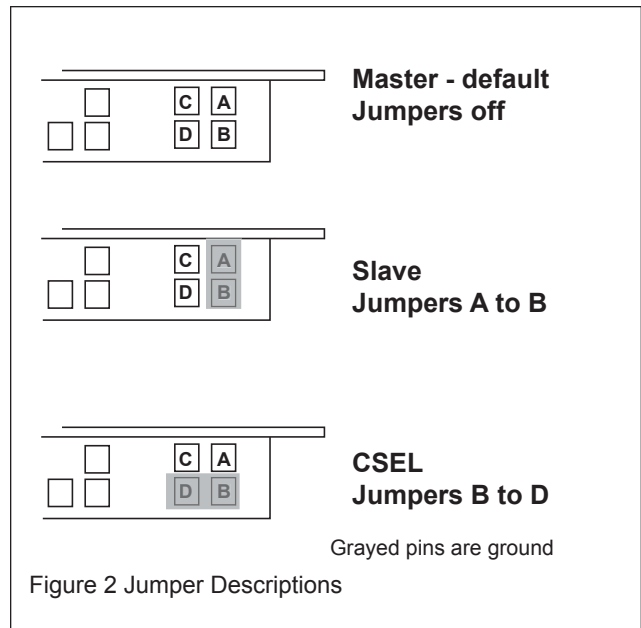
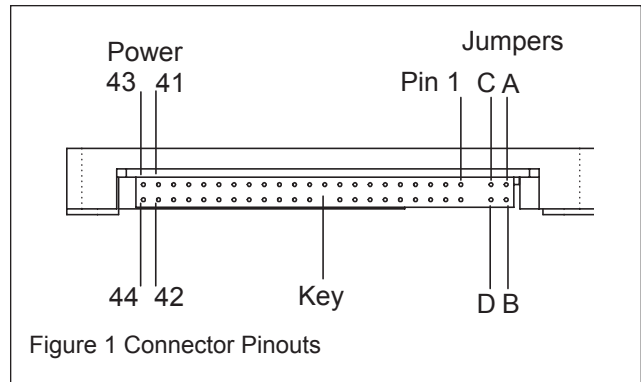

Signals preceded with a dash (-) are active low as the asserted state. Signals without a dash are asserted high.



**CONFIGURATION DESCRIPTIONS**

Signal Name	Dir	Pin	Description
DA[2:0]	I	36, 33, 35	A2-A0 are used to select the one of eight registers in the Task File.
-CS[1:0]	I	38, 37	-CS0 is the chip select for the Task File registers while -CS1 is used to select the Alternative Status Register and the Device Control Register.
CSEL	I	28	This internally pulled-up signal is used to configure this device as a Master or a Slave, if J_CSEL_-EN is grounded by a jumper from B to D. When the pin is grounded, this device is configured as a Master. When the pin is open, this device is configured as a Slave.
DB[15:0]	I/O	18, 16, 14, 12, 10, 8, 6, 4, 3, 5, 7, 9, 11, 13, 15, 17	All Task File operations occur in byte mode on the low order bus DD[7:0] while all data transfers are 16 bit using DD[15:0].
-DASP	I/O	39	This input/output is the Disk Active/Slave Present signal in the Master/Slave handshake protocol.
DMARQ	O	21	DMA transfer request.
-DMACK	I	29	DMA request acknowledge.
-DIOW:STOP	I	23	The I/O Write strobe pulse is used to clock I/O data on the Card Data bus into the Drive controller registers when the Drive is configured to use the I/O interface. The clocking will occur on the negative to positive edge of the signal (trailing edge). During Ultra DMA, this is the stop signal.
-DIOR: HDMARDY/ HSTROBE	I	25	This is an I/O Read strobe generated by the host. This signal gates I/O data onto the bus from the Drive. Ultra DMA control signal used to extend host transfer cycles.
INTRQ	O	31	Signal used to interrupt host when service is requested.
-IOCS16	O	32	This output signal is asserted low when this device is expecting a word data transfer cycle.
IORDY: DDMARDY/ DSTROBE	O	27	This output signal may be used as IORDY. Ultra DMA control signal used to extend host transfer cycles.
-PDIAG	I/O	34	This input/output is the Pass Diagnostic signal in the Master/Slave handshake protocol.
-RESET	I	1	This input pin is the active low hardware reset from the host.
GND	--	2, 19, 22, 24, 26, 30, 40, 43	Ground
Key	--	20	This pin is keyed so that the drive can only be connected with the cable pin 1 to drive pin 1.
J_-SLAVE	--	A	Master/Slave Jumper
J_CSEL_-EN	--	D	When low CSEL controls Master/Slave
N/C	--	44	No connect
+5V	--	42, 41	+5V
JP_GNDB/ JP_GNDC	--	B, C	Reserved for jumpers

Table 11 44-Pin Signal Description

**PACKAGE DIMENSIONS**

Refer to the figure below for the enclosure and mounting dimensions of the I25FB 2.5" drive. Dimensions are shown in mm[inches].

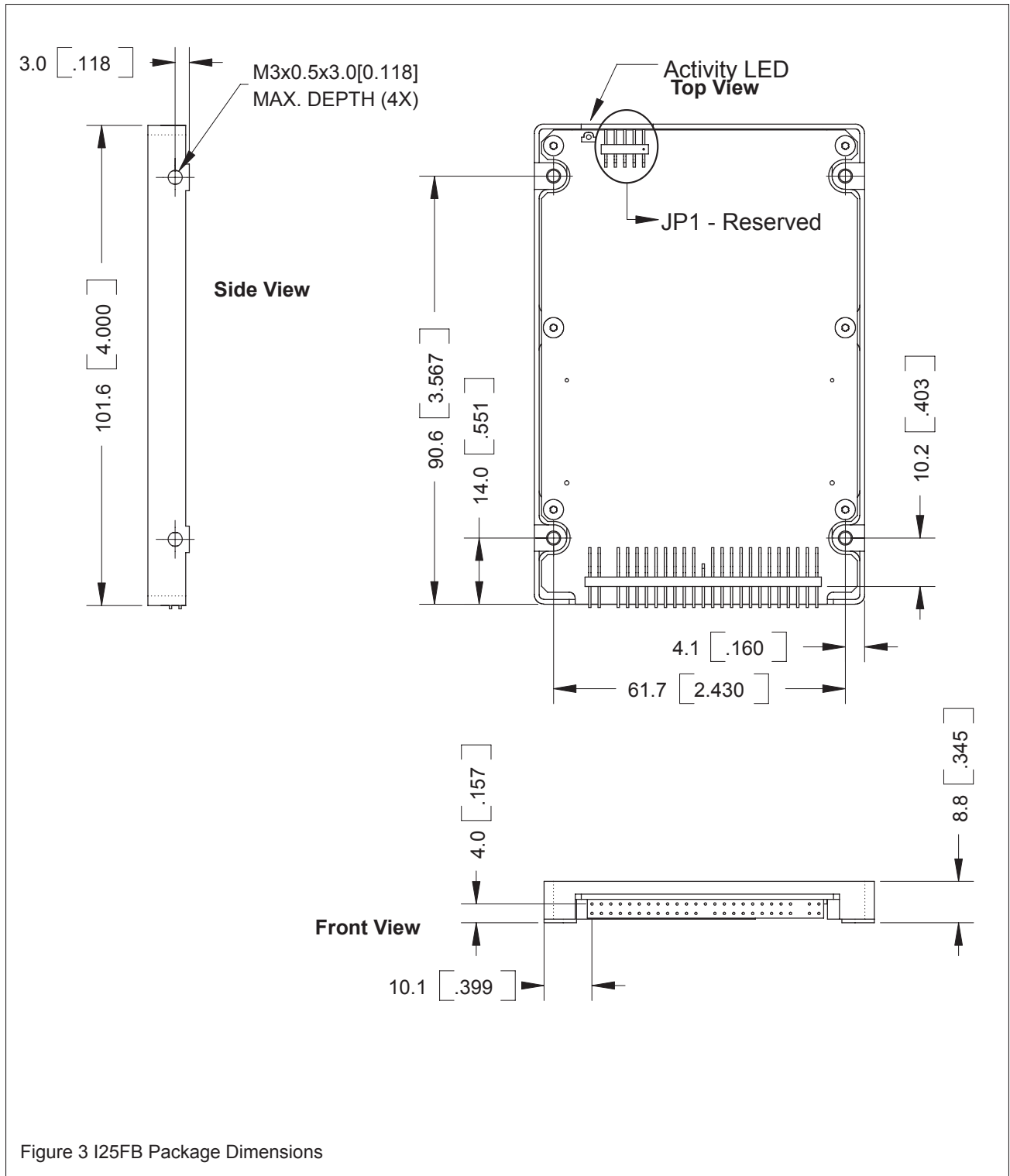

Figure 3 I25FB Package Dimensions

**PACKAGE DIMENSIONS - 1 EXPANDER**

Refer to the figure below for the enclosure and mounting dimensions of the I25FB 2.5" drive. Dimensions are shown in mm[inches].

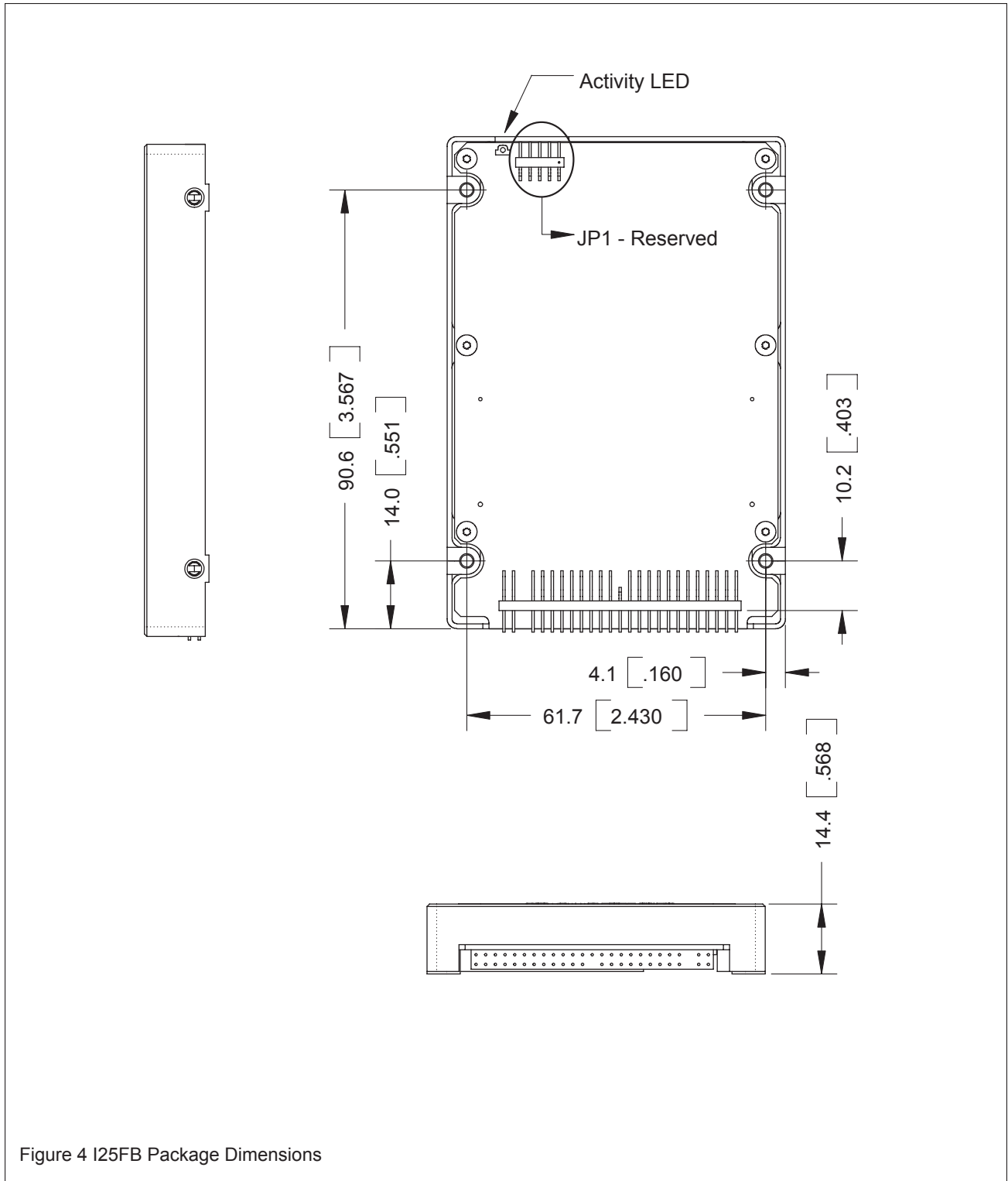

Figure 4 I25FB Package Dimensions

**PACKAGE DIMENSIONS - 2 EXPANDER**

Refer to the figure below for the enclosure and mounting dimensions of the I25FB 2.5" drive. Dimensions are shown in mm[inches].

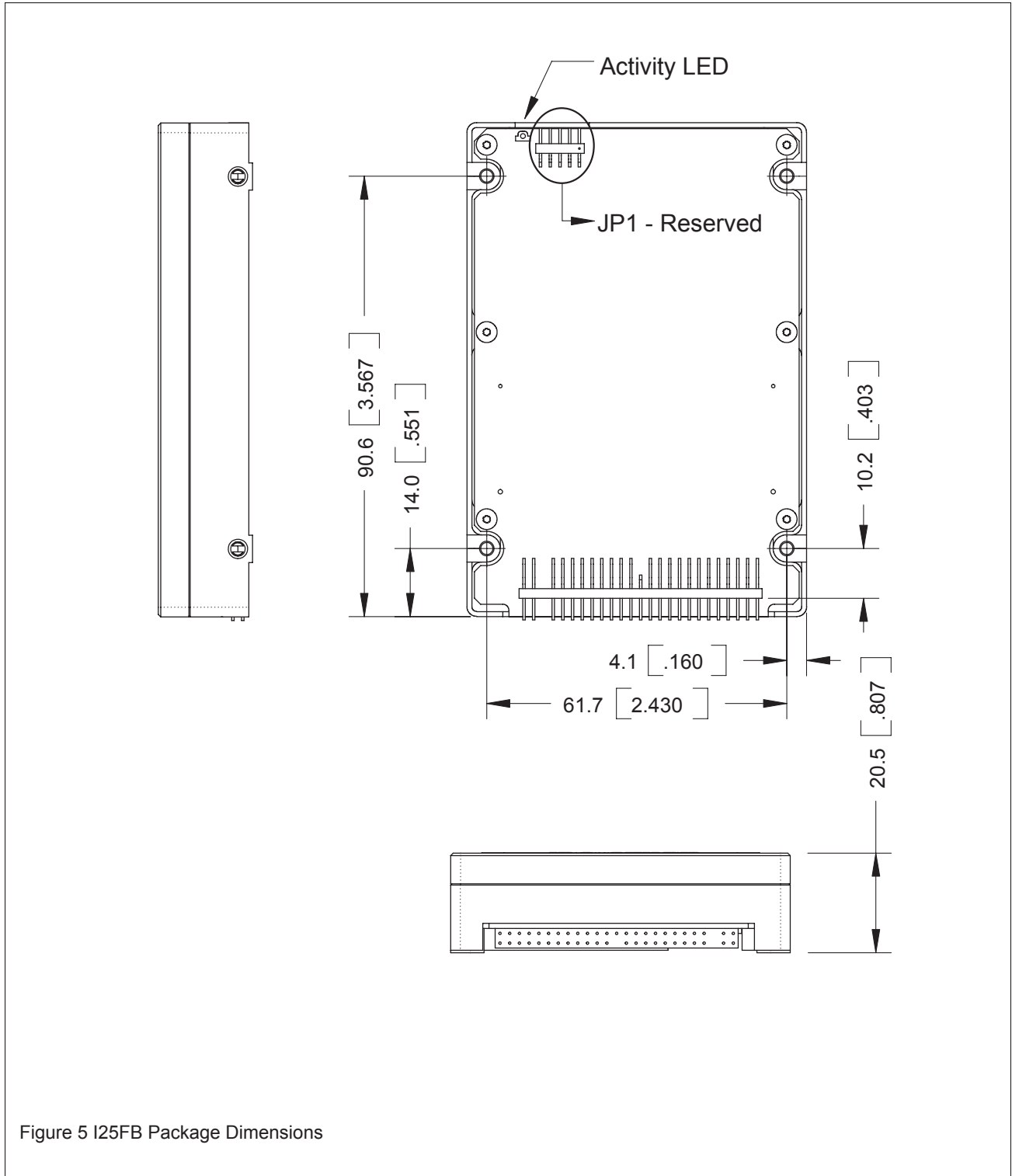

Figure 5 I25FB Package Dimensions

### PACKAGE DIMENSIONS - 3 EXPANDER

Refer to the figure below for the enclosure and mounting dimensions of the I25FB 2.5" drive. Dimensions are shown in mm[inches].

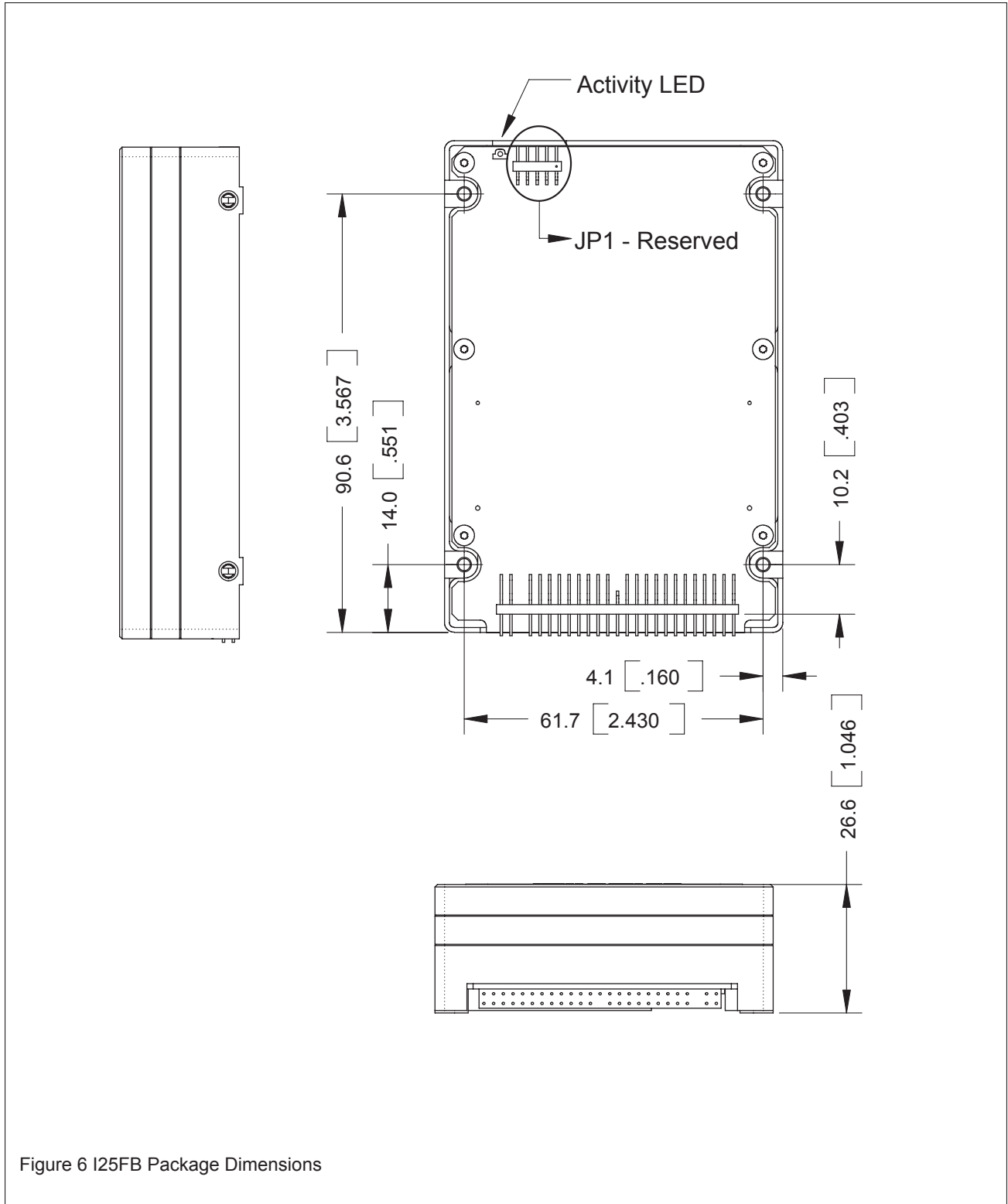
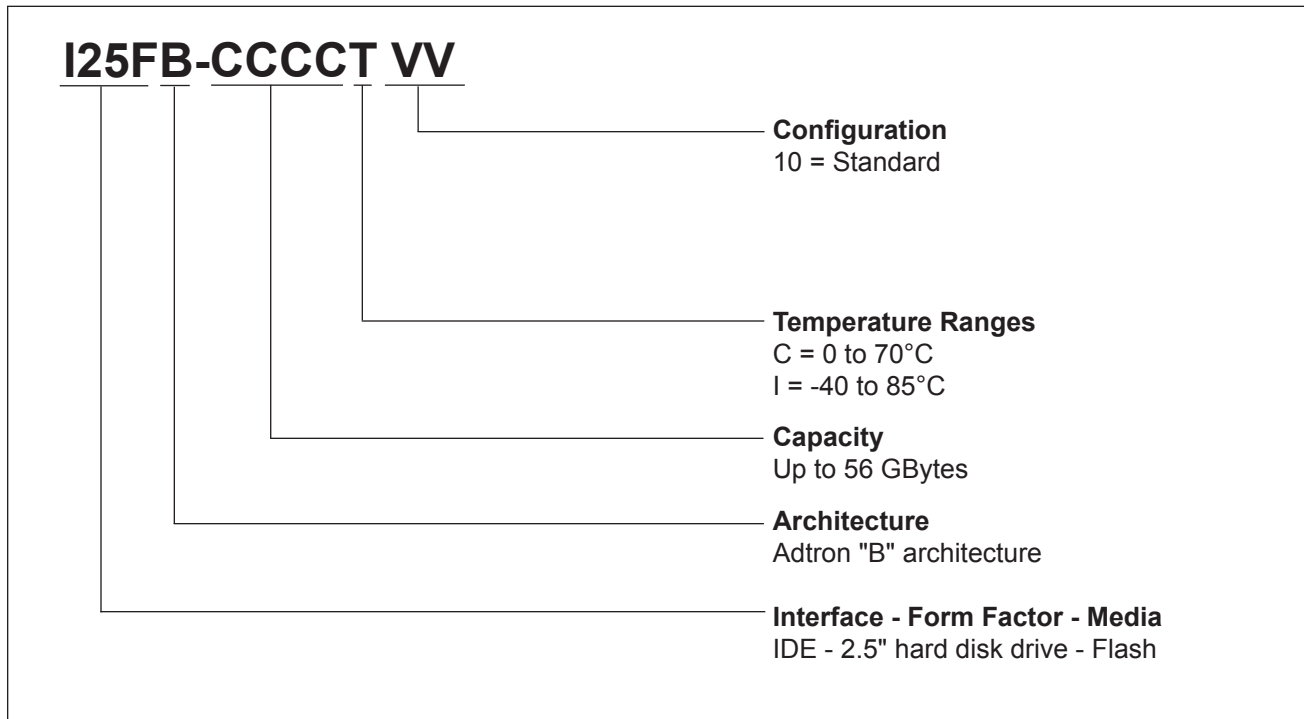

Figure 6 I25FB Package Dimensions

**ORDERING INFORMATION**

<b>Capacity Options (G = GBytes)</b>	<b>Height (Typ)</b>
512(MBytes), 1G, 2G, 3G, 4G, 6G, 8G	8.8mm [.346"]
12G, 16G, 20G, 24G	14.4mm [.568"]
28G, 32G, 36G, 40G	20.5mm [.807"]
44G, 48G, 52G, 56G	26.6mm [1.046"]

**Adtron Corporation**  
**www.adtron.com**  
 4415 E. Cotton Center Blvd., Suite 100  
 Phoenix, AZ 85040  
 Tel: (602) 735-0300 • Fax: (602) 735-0359  
 Email: info@adtron.com

**Made in the USA**

Trademarks are the property of their respective owners.  
 The information contained in this document is subject to change without notice and does not  
 represent or imply warranty, and no liability is assumed by Adtron Corp.