



Maintenance-Free Rechargeable Sealed Lead-Acid Battery



HR6-12

(24W/Cell 15Min Rate)

For High Rate Discharge

The battery is constructed by plates, separators, safety valves and container. Since the electrolyte is held by a glass-mat separator and plates, the battery can use in any direction and position without leakage.

PERFORMANCE SPECIFICATIONS

Nominal Voltage(V).....	12 volts(6cells in series)
Nominal Capacity(AH)	
10 Hour rate F.V.(1.75V/cell) (550mA to 10.50volts)	5.5A.H.
15 Min rate F.V.(1.30V/cell) (144W to 7.80volts)	3.0A.H.
Approximate Weight2100g(4.63lbs.)
Terminal	
Standard.....	Type T1
Optional.....	Type T2
Internal Resistance (Fully Charged Battery).....	<22mΩ
Maximum Discharge Current For 5 sec.(A).....	82.5A
Maximum Charge Current(A).....	1.65A
Ambient Temperature	
Charge.....	0°C(32°F)~40°C(104°F)
Discharge.....	-20°C(-4°F)~50°C(122°F)
Storage.....	-20°C(-4°F)~40°C(104°F)
Vibration test:	
Frequency: 16.7HZ	
Amplitude: 4mm	
Vibrate the battery horizontally or vertically for 60 minutes. The battery have no abnormality.	
Case.....	ABS
Dimension(mm/inch)	
Length ±1.5mm.....	151/5.94
Width ±1.5mm.....	51/2.01
Container Height ±1.5mm.....	94/3.70
Total Height ±2mm.....	100/3.94
Application.....	UPS, Laboratory Equipment, Toy-Cars, Power Packs, Fishing Lights.

HR6-12 Battery discharge characteristics (25 °C/77 °F)

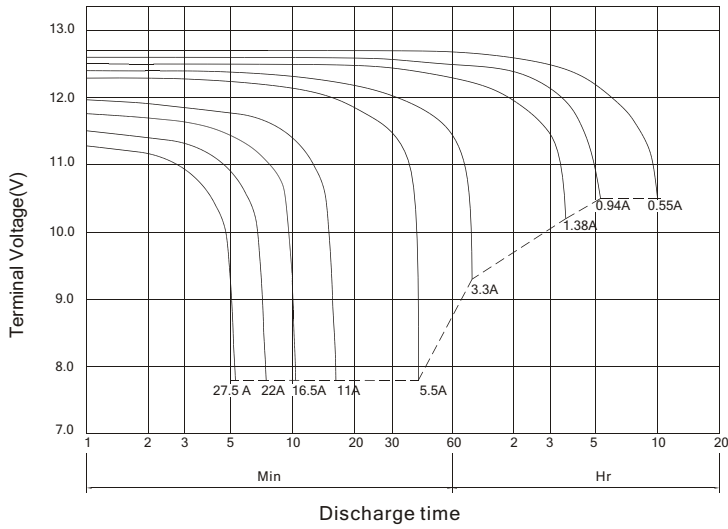

Battery Charging Characteristics

(Typical example of the charge characteristic for the standby use)

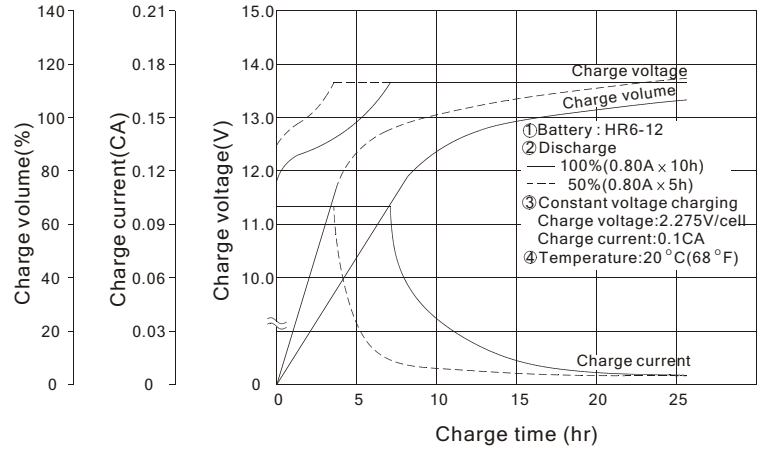

Charging Procedure

Application	Charging method	Charging Voltage at 20 °C (V/cell)	Temperature compensation coefficient of charging voltage (mV/°C/cell)	Max. charging current (CA)	Charging time 0.1CA, 20 °C (h)		Temp (°C)
					100% discharge	50% discharge	
For standby power source	Constant voltage & Constant current charging (with current restriction)	2.25~2.30	-3	0.3	24	20	0~40 (32~104°F)
For cycle service		2.40~2.50	-4	0.3	16	10	

*Temperature compensation of charging voltage is not needed, when using the batteries within 5 °C to 35 °C range.

Effect of Temperature on Long Term Float Life

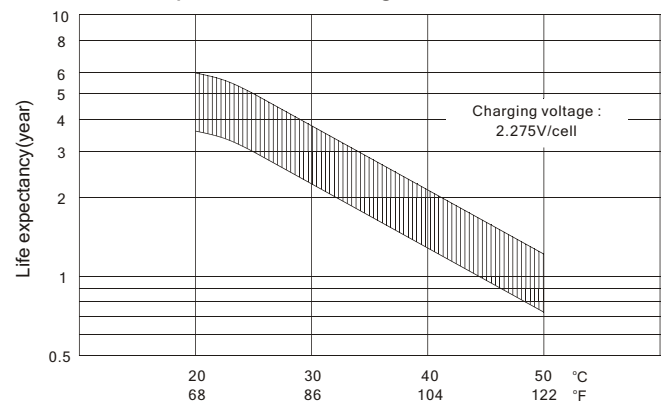

TERMINAL TYPE mm (inch)

OUTER DIMENSIONS

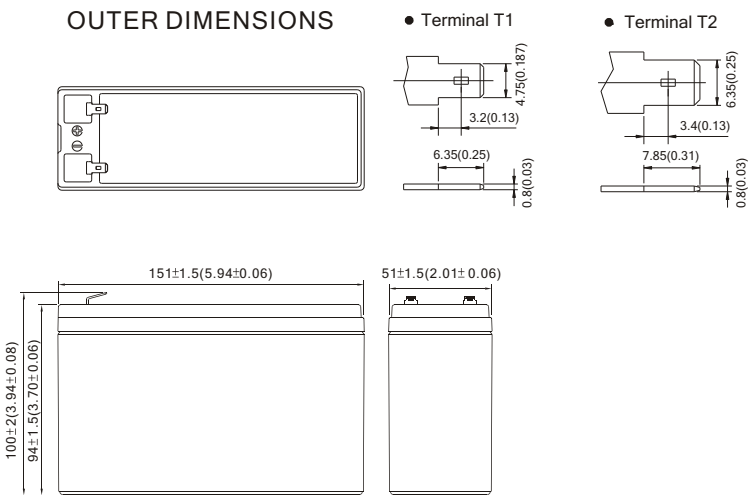

Battery temperature Constant power discharge characteristics at 25 °C/77 °F

Final Voltage	Discharge time							
	5Min	10Min	15Min	20Min	30Min	40Min	50Min	60Min
10.80V	246.0	168.0	121.7	103.8	78.9	60.0	50.1	44.1
10.20V	294.0	187.5	132.3	109.9	82.2	62.3	51.7	45.1
9.60V	315.0	197.3	138.3	114.0	84.0	63.7	52.8	45.9
9.00V	324.0	201.0	141.3	115.8	85.1	64.5	53.4	46.3
8.40V	330.0	203.7	142.9	116.9	85.7	64.9	53.9	46.7
7.80V	333.0	205.5	144.0	117.6	86.1	65.3	54.1	46.8

TERMINAL POSITION

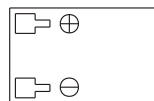

B.B. BATTERY CO., LTD.

Web Site: <http://www.bb-battery.com>

USA:
B&B BATTERY(USA) INC.
6415 RANDOLPH ST.COMMERCE,
CA,90040 U.S.A.
TEL:1-323-278-1900.1-800-278-8599
FAX:1-323-278-1268
E-Mail:sales@bb-battery.com

EUROPE:
B&B BATTERY(EUROPE) B.V.
3 WIJNGAARDVELD, 9300 AALST,BELGIUM
TEL:(00)32-53781567
FAX:(00)32-53781567
E-Mail:hansdevriese@bb-battery.com

CHINA FACTORY:
B.B. BATTERY CO., LTD.
CHENG DONG TRIAL AREA,HUANG GANG,
RAOPING, GUANG DONG,CHINA,515700
TEL:86-768-7601001-2
FAX:86-768-7601469
E-Mail:maggy@bb-battery.com

HONG KONG:
NATIONAL TRADING LTD.
TEL:852-2301-3800
FAX:852-2739-1182
E-Mail:bbhk@hkstar.com

JAPAN:
B&B BATTERY(JAPAN) CO., LTD.
1375-11 NARAHARA-MACHI,HACHIOJI,
TOKYO 193-0803,JAPAN.
TEL:81-426-256-537
FAX:81-426-256-537
E-Mail:miyata@bb-battery.com

TAIWAN:
B.B. BATTERY(TAIWAN) CO., LTD.
TEL:886-6-502-5150
FAX:886-6-589-8087
E-Mail:maggy@bb-battery.com

