

SPECIFICATION

SWITCHING POWER SUPPLY

BPS-250S 6-OUTPUT

SINGLE POWER 250W

BEST POWER SOLUTIONS, INC.

9F, NO.196-7, SEC.3, TA-TUNG RD SHI CHIH,
TAIPEI, TAIWAN, R.O.C.

Tel: 886-2-8647-1188

Fax: 886-2-8647-3322

1.0	General
1.1	Parameter Specifications
2.0	Input Characteristics
2.1	Input Voltage
2.2	Input Waveform
2.3	Input Frequency
2.4	Input Current
2.5	In-Rush Current
2.6	Line Regulation
2.7	Input Leakage Current
2.8	Isolation (Hi-Pot)
3.0	Output Characteristics
3.1	DC Output Characteristics
3.2	Overshoot
3.3	Efficiency
4.0	Time Sequence
4.1	Hold-Up Time
4.2	Power Good Signal
4.3	+5 Volt & +3.3V Power Good Output Rise Time
4.4	Start-Up Time
4.5	Dynamic Load Response Time
5.0	Protection
5.1	Over Power Protection
5.2	Over Voltage Protection
5.3	Short Circuit Protection
5.4	No Load Operation
5.5	5VSB (Standby)
5.6	PS-ON (Remote ON/OFF)
5.7	3.3V Sense
6.0	Physical Characteristics
6.1	Size
6.2	Mounting Requirements

6.3	Weight
6.4	Cooling
7.0	Connectors
7.1	DC Output Wire List
7.2	AC Input
8.0	Environmental
8.1	Temperature
8.2	Relative Humidity
8.3	Altitude
8.4	Shock
8.5	Vibration
8.6	Power Line Transient
8.7	Acoustic Noise
9.0	Regulatory Agency Certification
9.1	RFI/EMI Standards
9.2	Safety Standards
10.0	Reliability
10.1	Mean Time Between Failures (MTBF)
10.2	Warranty

1.0 General

This specification describes the physical, functional and electrical characteristics of a single power 250 watts, 6-output, fan-cooled switching power supply.

1.1 Parameter Specifications

Unless specified otherwise, all parameters must be not over the limits of temperature, load and input voltage.

2.0 Input Characteristics

2.1 Input Voltage

Normal	Minimum	Maximum
115 VAC	90 VAC	132 VAC
230 VAC	180 VAC	264 VAC

Input voltage range set with a 115/230 VAC selector.

2.2 Input Waveform

The unit is capable of operating with a 10% distorted sinewave input as measured by a distortion analyzer. Its flattopping clipped 10% from the peak value of standard sinewave.

2.3 Input Frequency

47 Hz to 63 Hz

2.4 Input current

Input Power	400W
Vin: 115VAC	6 A
Vin: 230VAC	3.5 A

2.5 In-Rush Current

CONDITIONS

132/264VAC, Full load.

Turn off 1 sec; turn on at peak of input voltage cycle.

LIMITS

No damage shall occur or components over stressed, input fuse shall not blow.

25°C Air Ambient cold start.

2.6 Line Regulation

CONDITIONS

Full load,
90/180 - 132/264 VAC input

LIMITS

+/-1%

2.7 Input Leakage Current

Input leakage current from line to ground will be less than 3.5 mA rms. Measurement will be made at 240 VAC and 60Hz.

2.8 Isolation (Hi-pot)

1500VRMS, 50Hz, for one (1) minute between each input AC line and the grounding conductor.

3000VRMS, 50Hz, for one (1) Minute between the input AC lines and secondary low voltage outputs and shields.

All isolation transformers will have been tested prior to assembly into a power supply unit. Any such transformers without a grounded shield will be tested to 3750 VRMS.

3.0 Output Characteristics

3.1 DC Output Characteristics

To be met under all combinations of loading.

Output Voltage	V1 +5V	V2 3.3V	V3 +12V	V4 -5V	V5 -12V	5VSB Standby
Max. Load	25A	15A	10A	0.5A	0.5A	2A
Min. Load	3A	0A	1A	0A	0A	0A
Max. Power	150W			2.5W	6W	7.5W
	234W					
Load Reg. %	+/-5%	+5/-3%	+/-5%	+/-10%	+/-10%	+/-5%
Cross Reg. %	+/-5%	+5/-3%	+/-5%	+/-10%	+/-10%	+/-5%
Line Reg. %	+/-1%	+/-1%	+/-1%	+/-1%	+/-1%	+/-1%
Ripple %	+/-1%	+/-1%	+/-1%	+/-2%	+/-2%	+/-1%
Noise %	+/-1%	+/-1%	+/-1%	+/-2%	+/-2%	+/-1%

Note 1: The +12 Volt output of the power supply must be capable of 13 Amps peak for 10 seconds. A +/-5% tolerance is permissible. Output voltage is measured at the load and of the output cable.

Note 2: Noise bandwidth is from DC to 20 MHz.

Note 3: Regulation tolerance shall include temperature change, warm up drift and dynamic load.

3.2 Overshoot

Any output overshoot at TURN-ON shall not exceed 5% (+5V/+12V/+3.3V outputs) and 10% (-5V/-12V outputs) of nominal voltage value.

3.3 Efficiency

70% min. at full load test.

4.0 Time Sequence

4.1 Hold-Up Time

Unit shall continue to supply regulated DC outputs and power good signal for at least 20 milliseconds at 115/230 VAC full load after a loss of AC input voltage, which shall be represented by a short circuit at the AC input.

4.2 Power Good Signal

When the power supply is turned off for a minimum of 1.0 second and turned on, the power-good signal as described below will be generated. The power supply shall provide a power-good signal to indicate proper operation of the power supply. This signal shall be a TTL compatible high level for normal operation; low level for fault conditions. Power-good shall go to a low level at least 1 ms before the +5V output voltage falls below the regulation limits described in 3.1 DC output Characteristics. The operation point used as a reference for measuring the 1ms shall be minimum line voltage and maximum load.

All waveform transitions shall be smooth and monotony, i.e. no oscillations. The power-good signal shall stay low (during POWER-ON) until all output voltages are stable within regulation limits. The power-good signal shall have a TURN-ON delay greater than 100 ms but less than 500 ms.

4.2.1 Fan out

Power-Good output circuit shall consist of an active pull down component and a passive pull up resistor. Power-Good output voltage to be met under recommended loading conditions.

CONDITIONS

$I_{OH} = -140\mu A$ Min.

LIMITS

$V_{OH} = 2.7V$ Min.

$I_{OL} = 2.8\text{mA Min.}$

$V_{OL} = 0.4\text{V Min.}$

4.3 +5 V & +3.3V and Power Good Outputs Rise Time

4.3.1 +5 V & +3.3V Output Rise Time

The +5 Volt and +3.3 Volt output shall have a turn-on rise time of less than 100ms under all load conditions. Rise time is measured between 0.0 and 2.48/4.75 volts. The +5 V and +3.3V output shall not vary from a smooth curve by more than 0.5 VP-P during turn-on and turn-off.

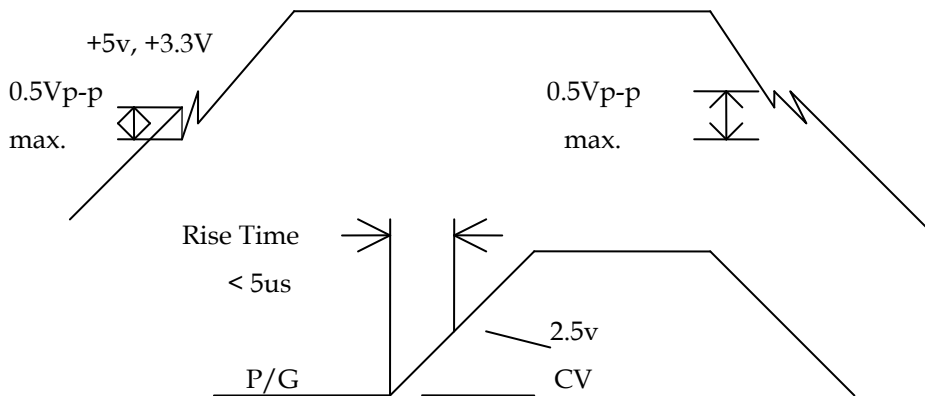

4.4 Start-up timing

All outputs shall be stable and in regulation in less than 2.0 second under all load and line conditions. Start-up time is measured between the AC turn-on and 4.75 volts on +5v output.

4.5 Dynamic Load Response Time

Transient response is measured by switching the output load from 80 to 100 to 80 percent of its full value at a frequency of 100 Hz and 50% duty cycle, step load change is 0.5A/us, The magnitude V_r is less than +/- 5% of +5V and +12V outputs, the recovery time T_r is less than 1ms.

5.0 Protection

5.1 Over Power Protection

This power supply shut down all DC outputs when +5 Vdc and +12 Vdc outputs are overloaded to the limit. The power supply logic shall latch into the off state requiring a power on cycle to be performed by the operator. The power supply will turn-off within 20 ms of the occurrence of the overload. The -5 Vdc and -12 Vdc outputs will be internally current limited.

CONDITIONS

LIMIT

90/180 VAC input

When output power is over to 120%

5.2 Over Voltage Protection

The power supply shall latch off if the +5 VDC or 3.3VDC or +12 VDC maximum voltages exceeds the limits shown. The AC must be recycled to restart.

+5 VDC

CONDITIONS

All operating

LIMITS

6.25 VDC +/- 0.65 VDC

+3.3 VDC

CONDITIONS

All operating

LIMITS

4.10 VDC +/- 0.40 VDC

+12 VDC

CONDITIONS

All operating

LIMITS

13.6 – 15.6 VDC

5.3 Short Circuit Protection

A short circuit placed on any output shall cause no damage to this unit.

5.4 No Load Operation

When primary power is applied, with no load on any output voltage, no damage or hazardous conditions shall occur. In such a case, the power supply shall power up and stabilize. However, minimum load required 3A for +5V and 1A for +12V.

5.5 5VSB (Standby)

The 5VSB output is always on (+5V Standby) when AC power is applied and power switch is turned on. The 5VSB line is capable of delivering at a maximum of 5A for PC board circuit to operate.

5.6 PS-ON (Remote ON/OFF)

PS-ON is an active low signal that turns on the entire main power rail including 3V, 5V, -5V, 12V & -12V power rails. When this signal is held by the PC board or left open circuited, outputs of the power rails should not deliver current and should be held at a zero potential with respect to ground. Power should only be delivered to the rails if PS-ON signal is held

at ground potential. This signal should be held at +5VDC by a pull-up resistor internal to the power supply.

Power On	P1-PIN #14 PS-ON	Power Switch	P1-PIN #14 PS-ON
ON	L	ON	IN
OFF	H	ON	IN
OFF	X	ON	OUT
OFF	X	OFF	X

5.7 3.3V Sense

A remote 3.3V sense line can be added to the P1 connector Pin2 to allow for accurate control of the 3.3VDC line directly at motherboard loads. Due to potential voltage drops across the connector and traces leading to the motherboard components, it may be advantageous to implement a 3.3V sense line that remotely monitors the 3.3VDC power level at the load on the motherboard.

6.0 Physical Characteristics

6.1 Size

100*40.5*190mm

6.2 Mounting Requirements

See Figure 6

6.3 Weight

1 Kg

6.4 Cooling

Fans: NMB (1608KL-04W-B50), equivalent or better. Airflow from the power supply should be in exhaust direction and shall be rated at 7.3 cfm minimum.

7.0 Connections

7.1 DC Output Wire List

+ For ATX Mother Board

<u>Connector</u>	<u>Output</u>	<u>Wire Color</u>	<u>Wire Size</u>
ATX 20 Pin			
P1-1	+3.3V	BRN	16 AWG
P1-2	+3.3V	BRN	16 AWG
P1-3	GND	BLK	18 AWG

P1-4	+5V	RED	18 AWG
P1-5	GND	BLK	18 AWG
P1-6	+5V	RED	18 AWG
P1-7	GND	BLK	18 AWG
P1-8	PW-OK	ORG	16 AWG
P1-9	5VSB	PURPLE	18 AWG
P1-10	+12V	YEL	18 AWG
P1-11	+3.3V	BRN	16 AWG
P1-12	-12V	BLUE	18 AWG
P1-13	GND	BLK	18 AWG
P1-14	PS-ON	GRN	18 AWG
P1-15	GND	BLK	18 AWG
P1-16	GND	BLK	18 AWG
P1-17	GND	BLK	18 AWG
P1-18	-5V	WHT	18 AWG
P1-19	+5V	RED	18 AWG
P1-20	+5V	RED	18 AWG
4 PIN for P4			
Pn-1	COM	BLK	18 AWG
Pn-2	COM	BLK	18 AWG
Pn-3	+12V	YEL	18 AWG
Pn-4	+12V	YEL	18 AWG
P11 · P12			
Pn-1	+5V	RED	22 AWG
Pn-2	COM	BLK	22 AWG
Pn-3	COM	BLK	22 AWG
Pn-4	+12V	YEL	22 AWG
P13 · P14			
Pn-1	+12V	YEL	18 AWG
Pn-2	COM	BLK	18 AWG
Pn-3	COM	BLK	18 AWG
Pn-4	+5V	RED	18 AWG
P15 · P16			
Pn-1	+12V	YEL	18 AWG
Pn-2	COM	BLK	18 AWG
Pn-3	COM	BLK	18 AWG
Pn-4	+5V	RED	18 AWG

8.2 AC Input

IEC 320 power inlet with EMI filter.

9.0 Environmental

9.1 Temperature

9.1.1 Operating

50 to 122 °F (0 to 50 °C). Derate Linearly to 50% at 70 °C

9.1.2 Non-Operating

-4.0 to 140 °F (-20 to 60°C)

9.2 Relative Humidity

9.2.1 Operating

20 to 90 % non-condensing at 104°F (40 °C).

9.2.2 Non-Operating

5 to 95 % non-condensing at 122°F (50°C).

9.3 Altitude

9.3.1 Operating

Sea level to 10,000 feet.

9.3.2 Non-Operating

Sea level to 40,000 feet.

9.4 Shock

9.4.1 Operating

The power supply shall exhibit no signs of damage or degradation of performance when subjected to a shock of 5g's for 11 ms, with a 1/2 sine wave for each of the perpendicular axes X, Y and Z.

9.4.2 Non-Operating

The power supply shall exhibit no signs of damage or degradation of performance when subjected to a shock of 30g's for 11 ms, with a 1/2 sine wave for each of the perpendicular axes X, Y and Z.

9.5 Vibration

9.5.1 Operating

The power supply shall be subjected to a vibration test consisting of a 10 to 500 Hz sweep at a constant acceleration of 0.5g for a duration of one (1) hour for each of the perpendicular axes X, Y and Z. The output voltages shall remain within specification.

9.5.2 Non-Operating

The power supply shall be subjected to a vibration test consisting of a 10 to 300 Hz sweep at a constant acceleration of 2.0g for a duration of one (1) hour for each of the perpendicular axes X, Y and Z. The power supply shall not incur physical damage or degradation of any characteristics below the performance specifications.

9.6 Power Line Transient

9.6.1 Drop Out

With a full cycle input voltage dropout at 50Hz, the unit shall operate within the prescribed voltages with a dropout cycle repetition rate of 500ms.

CONDITIONS

Full load, Nom. Input AC Voltage

LIMITS

Meet all requirements

9.6.2 Transient Voltage Spikes

The unit shall meet the following standards, The IEEE Standard 587-1980 for surge withstand capability under categories A and B. The crest value of the first half peak of the injected Ring wave (0.5/10us) and Bi-wave (1.2/50us) will be 3K volts open circuit and 3KA (8us×20us) short circuit.

IEC 801-2 (ESD) to a level of 8KV contact, and 15K air discharge without causing the device(s) to fail the test.

IEC 801-4 (EFT) on the power lines and all I/O cables to a level of 2.5KV without causing the Device(s) to fail the test.

IEC 801-5 Surge immunity measurement on the input power source of 2.5KV.

All output shall be stable and in regulation.

9.7 Acoustic Noise

The power supply shall be tested in accordance with the ANSIS12.10-1985 standard specifications. The "A" weighted overall sound pressure level as well as individual octave band levels from 63 Hz to 16,000 Hz is measured with the noise meter placed 1 meter from the nearest vertical surface of

center of fan installed in power supply.

CONDITIONS

115 VAC Input, full load of +5V
0.5A of +12V.

LIMITS

Acoustic noise is 40 db maximum

Octave Band Center Frequency (Hz)								A-Weighted
125	250	500	1k	2k	4k	8k	16k	Max. Sum
20	36	42	42	42	36	30	20	40dBA

10.0 Regulatory Agency Certification

10.1 RFI/EMI Standards

The power supply, when installed in system, shall MEETS with the following radiated and conducted emissions standards:

- a) FCC part 15, Subpart A, Class A computing devices.
- b) CISPR22 (EN55022) Class A.
- c) VCCI Class 2.

These limits shall be met with a margin of at less 6dB at all applicable frequencies. The unit shall comply with the above limits when tested under all normal working conditions and with all interface cables connected.

10.2 Safety Standards

The power supply shall be certified with the following safety standards,

- a) UL 1950 (Information Processing/Business equipment).
- b) CSA C22.2, NO. 234-M90 level 6 (Safety of component, power supplies) or CSA C22.2, NO. 950-M89.
- c) TUV Certification to IEC 950 1ST edition with Amendment #1, #2, and EN60950
- d) CB Certificate & Test report deviation for the Nordic countries.
- e) CE Certificate & Test report.

11.0 Reliability

11.1 Mean Time Between failures (MTBF)

Using MIL217E the calculated MTBF = 100,000 hours at 25°C

11.2 Warranty

Two (2) years manufacture's warranty
Date code indicating week and year of manufacture.

Certificate

No: B 01 04 28112 011



Best Power Solutions Inc.

9F, No. 196-7, Sec. 3, Ta-Tung Rd.,
Shi-Chih, Taipei Hsien
Taiwan, R.O.C.

with production facility(ies)
28112

is authorized to label the following products with the
certification mark **E**
as shown in the certification mark list. See also notes overleaf.

Product: Netzgeräte
(Power Supply)

Model: BPS-xxxxy ("BPS")
S1-250 ("e-Server")
(xxx can be 400, 300 or 250, y can be S, S2 or SP)

Parameters:

Rated input voltage:	115/230 Vac
Rated input current:	See attachment
Rated frequency:	60/50 Hz
Rated output:	See attachment
Protection class:	I
Max. ambient temperature:	25°C

Degree of protection
against ingress of liquids: ordinary

Remark: When installing, all requirements of below
mentioned test standards must be fulfilled.

The product meets the relevant safety requirements and was tested
according to:

EN 60950/A11:1997

Report No: 61210105401

Released with the above certificate number by the
certification body of TÜV PRODUCT SERVICE GMBH.

Department:
Date:

TPEITE / Blsw
04-03-2001

Billie



IEC SYSTEM FOR CONFORMITY TESTING TO
STANDARDS FOR SAFETY OF ELECTRICAL
EQUIPMENT (IECEE)
CB SCHEME

SYSTEME CEI D'ESSAIS DE CONFORMITE AUX
NORMES DE SECURITE DE L'EQUIPMENT
ELECTRIQUE (IECEE)
METHODE OC

CB TEST CERTIFICATE CERTIFICATE D'ESSAI OC

Product
Produit

Name and address of the applicant
Nom et adresse du demandeur

Name and address of the manufacturer
Nom et adresse du fabricant

Name and address of the factory
Nom et adresse de l'usine

Rating and principal characteristics
Valeurs nominales et caractéristiques principales

Trade mark (if any)
Marque de fabrique (si elle existe)

Model/type Ref.
Ref. de type

Additional information (if necessary)
Information complémentaire (si nécessaire)

A sample of the product was tested and found
to be in conformity with
*Un échantillon de ce produit a été essayé et a été
considéré conforme à la*

as shown in the Test Report Ref. No.
which forms part of this certificate
*comme indiqué dans le Rapport d'essais numéro
de référence*

qui constitue un partie de ce certificat

Redundant power supply for building in

Best Power Solution Inc.,
9F, No. 196-7, Sec. 3, Ta-Tung Rd.,
Shi Chih, Taipei Hsien,
Taiwan

Best Power Solution Inc.,
9F, No. 196-7, Sec. 3, Ta-Tung Rd.,
Shi Chih, Taipei Hsien,
Taiwan

See page 2

6/3.5A 115/230V 60/50Hz,
Cl. I, DC-outputs: see page 2

BPS

BPS-...S.

"..." can be 300, 250 or 200, denoting max. output power
"..." can be 2 or blank, denoting with or without power switch,
for 300W model only

IEC 60950 2nd Edition, 1991 +
Amd. 1, 1992 + Amd. 2, 1993 + Amd. 3, 1995 + Amd. 4, 1996

2000 44172

This CB Test Certificate is issued by the National Certification Body
Ce Certificate d'essai OC est établi par l'Organisme National de Certification



P.O. BOX 73, BLINDERN
N-0314 OSLO, NORWAY

Date **06 December 2000**

Signature 
Lars Hjerpsæth
Principal Engineer

Northbrook, Illinois • (847) 272-8800
 Melville, New York • (631) 271-6200
 Santa Clara, California • (408) 985-2400
 Research Triangle Park,
 North Carolina • (919) 549-1400
 Camas, Washington • (360) 817-5500



BEST POWER SOLUTIONS INC
 MR A LIU
 9TH FL
 196-7 TATUNG RD, SEC 3
 HSI CHIH 221
 TAIPEI HSIEN TAIWAN

RE: Project Number(s) - 01NK94172

Your most recent Certification is shown below. You may also view this information, or a portion of this information (depending on the product category), on UL's Online Certifications Directory at www.ul.com/database. Please review the text and contact the Conformity Assessment Services staff member who handled your project if revisions are required. For instructions on placing an order for this information in a 3 x 5-inch format, you may refer to the enclosed order form for UL Card Service.

QQGQ2 December 26, 2001
 Power Supplies, Information Technology Equipment Including Electrical Business Equipment - Component

BEST POWER SOLUTIONS INC E173757
 9TH FL 196-7 TATUNG RD, SEC 3 HSI CHIH 221, TAIPEI
 HSIEN TAIWAN

Model No.	Rated Input			SC	Output							
	V	Hz			Max V	Max A	Max VA	OC	SP	EP	FC	GC
BPS-230MA1, ORION-230MA1, ERM-230MA1	115/230	60/50		0	+5.4	60	216	3	1950	20B	0	1
					+12.9	42	312					
					+3.3	52	94					
					-5.3	5.2	8					
					-12.4	4	30					
					+5Vsb*	1.5*	—					
BPS-230R2, ORION-2302	115/230	60/50		0	+5*	25*	—	3	1950	20B	0	1
					+3.3*	13*	—					
					+12*	13*	—					
					-5*	0.5*	—					
					-12*	1*	—					
					+5Vsb*	1.5*	—					
BPS-250AX	120-240	50-60		0	-12	5	—	2	1950	20B	0	1
					5	0.1	—					
					-5	5	—					
					12	10	—					
					3.3	15	—					
					5	25	—					
BPS-250D	-48	dc		2	5.35	30	147	2	1950	20B	0	0
					12.73	12.7	152					
					-5.87	2.3	8.9					
					-13.86	2.0	25.6					
BPS-250DC	48	dc		6	-10.7	6.0	61.2	3	1950	10	0	0
					4.34	37.9	164.48					
					-3.33	7.0	23.31					
					11.46	19.5	223.4					

Underwriters Laboratories Inc.®

Model No.	Rated Input			Output			OC	SP	EP	FC	GC
	V	Hz	SC	Max V	Max A	Max VA					
BPS-250DX	48	dc	6	-10.7 4.88 -3.33 11.46 2.98 4.34	6.0 0.11 7.0 37.9	61.2 0.536 23.31 223.4 68.54 164.48	3	1950	10	0	0
BPS-250MA2, ORION-250MA2, ERM-250MA2	115/230	60/50	0	+5* +12* +3.3* -5* -12* +5Vsb*	30* 14* 15* 0.5* 1* 1.5*	— — — — — —	3	1950	20B	0	1
BPS-250R2/2U, ORION-2502 /2U, ERM-250R2/2U	115/230	60/50	0	+5* +3.3* +12* -5* -12* +5Vsb*	30* 15* 14* 0.5* 1* 1.5*	— — — — — —	3	1950	20B	0	1
BPS-250RD	115/230	50-60	0	5.7 13 -5.3 -13	42.5 24.5 10.5 5.0	180 237 16.2 60	2	1950	20B	0	0
BPS-250RDA, BPS-250RDA1	120-240	50-60	0	5.7 13 -5.3 -13	42.5 24.5 10.5 5.0	180 237 16.2 60	2	1950	20B	0	0
BPS-250RDDX,	48	dc	3	5.29 4.96 12.36 -4.88 -10.05 5.17	61.40 32.50 34.00 8.74 2.25 2.00	132.00 76.57 261.46 18.56 9.05 9.42	3	1950	20 Adc	0	1
BPS-250RDX, BPS-270RDX	115/230	50-60	0	5.3 12.9 5.1(Vsb) 3.4 -5.4 -12.5	48 23.5 2.5 30.5 7 4	165 183 12 78 22 40	2	1950	20B	0	0
BPS-250S ORION-250S EG250S-V S1-250 ORION-200S S1-200	115/230	60/50	0	6.3 13.1 3.4 -5.3 5.4 5.4	45.0 35.0 53.0 12.4 3.2 3.2	193 364 120 28 13.6 13.6	3	1950	20B	0	1
BPS-270A	120-240	50-60	0	-12 5 12 5	5 0.1 10 30	— — — —	2	1950	20B	0	1
BPS-270RD	115/230	50-60	0	5.6 12.6 -5.1 12.6	48 21 10.5 21	192 195.3 19.8 59.2	2	1950	20B	0	0
BPS-270RDA	120-240	50-60	0	5.6 12.6 -5.1 12.6	48 21 10.5 21	192 195.3 19.8 59.2	2	1950	20B	0	0
BPS-300A	120-240	50-60	0	-12 -5 12 5	5 5 12 30	— — — —	2	1950	20B	0	1
BPS-300AX	120-240	50-60	0	-12.03	5.6	58.9	2	1950	20B	0	1

Underwriters Laboratories Inc.®

Model No.	Rated Input		SC	Output			OC	SP	EP	FC	GC
	V	Hz		Max V	Max A	Max VA					
BPS-300DC	48	dc	6	5.12	2.5	8.16	3	1950	10	0	0
				-5.04	4.6	19.96					
				12.03	20.2	233.9					
				3.2	23.8	71.6					
				4.88	40	188					
				-10.7	6.5	61.2					
				-3.33	7.0	23.31					
BPS-300DX	48	dc	6	11.46	19.5	223.4	3	1950	10	0	0
				4.34	37.9	164.48					
				-10.7	6.5	61.2					
				4.88	0.11	0.536					
				-3.33	7.0	23.31					
				11.46	19.5	223.4					
				2.98	23	68.54					
BPS-300MA2, ORION-300MA2, ERM-300MA2	115/230	60/50	0	4.34	37.9	164.48	3	1950	20B	0	1
				+5*	30*	—					
				+12*	14*	—					
				+3.3*	15*	—					
				-5*	0.5*	—					
				-12*	1*	—					
				+5Vsb*	15*	—					
BPS-300MA3, ORION-300MA3, ERM-300MA3	115/230	60/50	0	+5.6	49	199	3	1950	20B	0	1
				+13.2	44	320					
				+3.6	48	75					
				-5.4	7	11					
				-13.1	5.3	35					
				+6.9Vsb	3	13					
				+5.7	109	447					
BPS-300R2, ORION-300R2, ERM-300R2	115/230	60/50	0	+3.6	85	154	3	1950	20B	0	1
				+13.3	75	646					
				-5.4	13	90					
				-13.2	9	62					
				+6.7Vsb	6.1	27					
				+5*	30*	—					
				+3.3*	15*	—					
BPS-300R2/2U, ORION-300R2/2U, ERM-300R2/2U	115/230	60/50	0	+12*	14*	—	3	1950	20B	0	1
				-5*	0.5*	—					
				-12*	1*	—					
				+5Vsb*	15*	—					
				6.33	64.0	276					
				13.7	52.0	547					
				3.36	60.0	107					
BPS-300S2 ORION-300S2 BPS-300S ORION-300S	115/230	60/50	0	-5.76	12	28	3	1950	20B	0	1
				-14.58	8.9	82					
				5.3	2.5	11.3					
BPS-320A	120-240	50-60	0	-12	.5	—	2	1950	20B	0	1
				-5	.5	—					
				12	14	—					
				5	30	—					
				-12	5.6	58.9					
BPS-320AX	120-240	50-60	0	5	2.5	8.16	2	1950	20B	0	1
				-5	4.6	19.96					
				12	20.2	233.9					
				3.3	23.8	71.6					
				5	40	188					
BPS-320/2, BPS-320/2A	115/230	60/50	0	5.09	44.6	205	3	1950	20B	2.6	1
				13.0	34.5	267					
				3.45	38.2	71.9					
				5.00	5.2	13.4					
				13.11	2.3	18.3					
				5.69	2.5	10.3					

Underwriters Laboratories Inc.®

Model No.	Rated Input		SC	Output			OC	SP	EP	FC	GC
	V	Hz		Max V	Max A	Max VA					
BPS-370RDX, -320RDX, BPS-300RDX	115/230	60/50		5.4 13.4 3.4 5.1 12.7 5.4	135 73 80 1.7 1.9 5.5	460 720 106 5.1 18 23	3	1950	20B	2,6	0
BPS-400SP ORION-400SP BPS-400S2 BPS-400RM, BPS-400S, ORION-400S2, EG400S-V BPS-300RPX, BPS-300SP2, BPS-300SPP, BPS-350SPP	115/230	60/50	0	6.33 13.7 5.26 -5.76 -14.58 5.3	64.0 52.0 2.79 12 8.9 2.5	276 547 12.45 28 82 11.3	3	1950	20B	0	1
BPS-450R3, ORION-2303, ERM-450R3,	115/230	60/50	0	+5.4 +3.4 +13.2 -5.3 -13.2 +6.6Vsb	140 130 70 6.5 35 9.3	525 216 627 16 35 34	3	1950	20B	0	1
BPS-250DS, BPS-300DS, BPS-300DSP	-48	dc	0	5.28 3.44 12.35 -4.8 -11.82 5.22	34 36.1 29.4 1.2 0.6 3.3	139.6 93.5 291.6 3.58 4.45 15.5	3	1950	20B	2,3	0

* - Rated value.
Marking: Company name and model designation.

See General Information Preceding These Recognitions
For use only in equipment where the acceptability of the combination is determined by Underwriters Laboratories Inc.



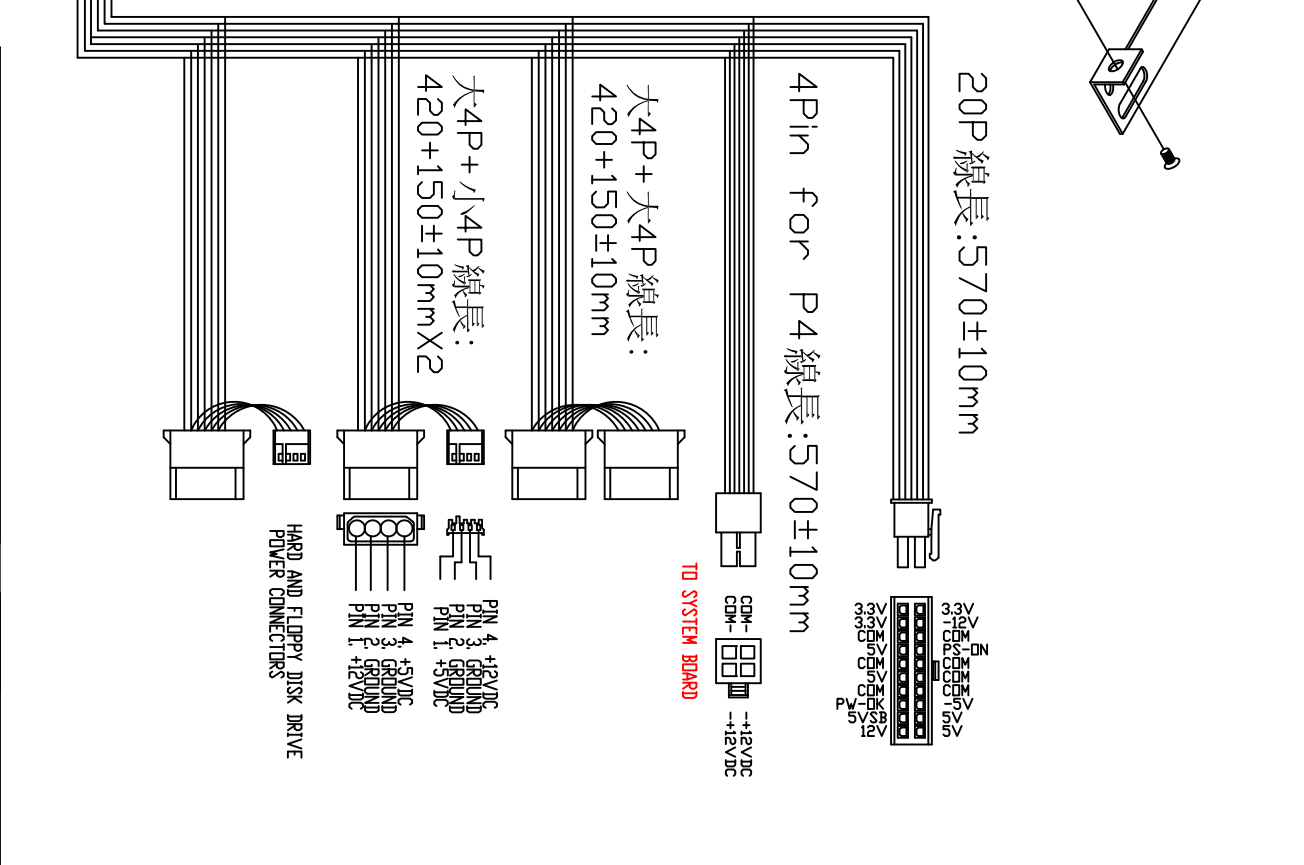
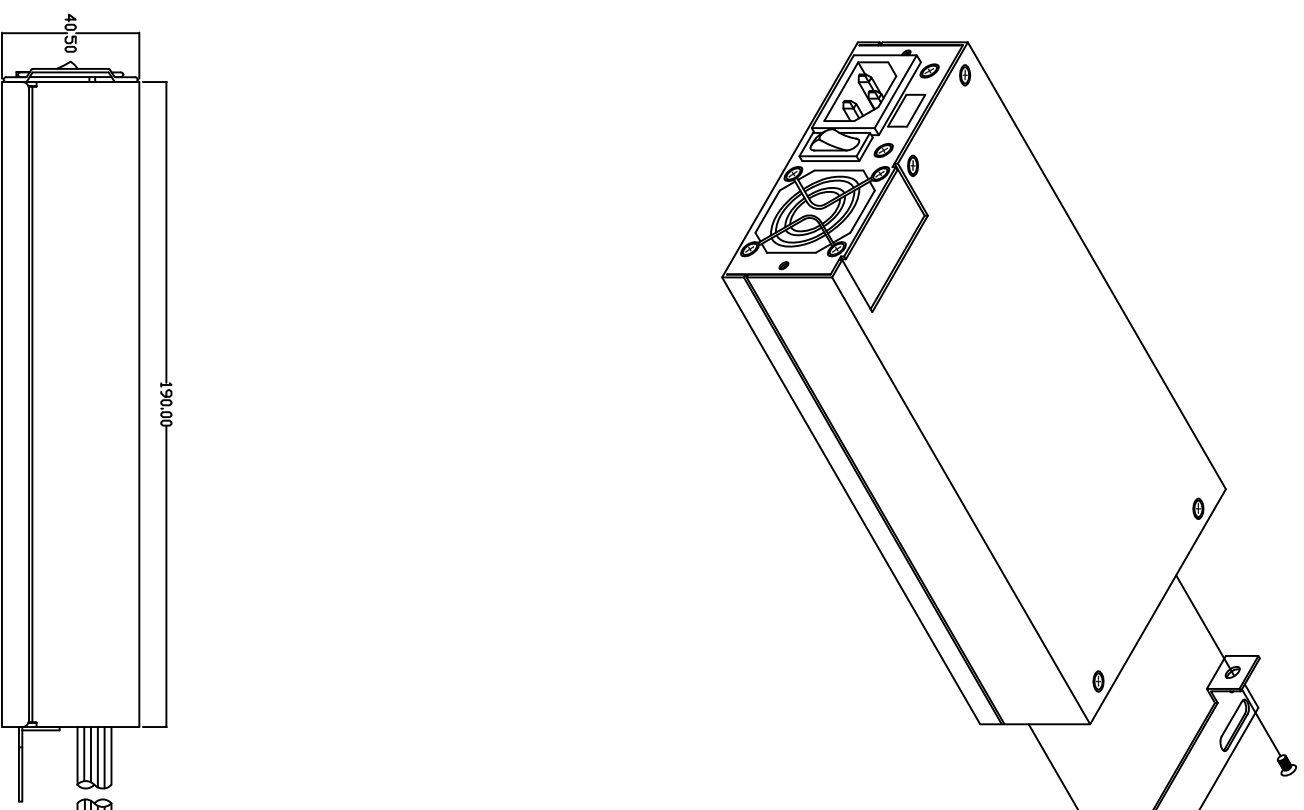
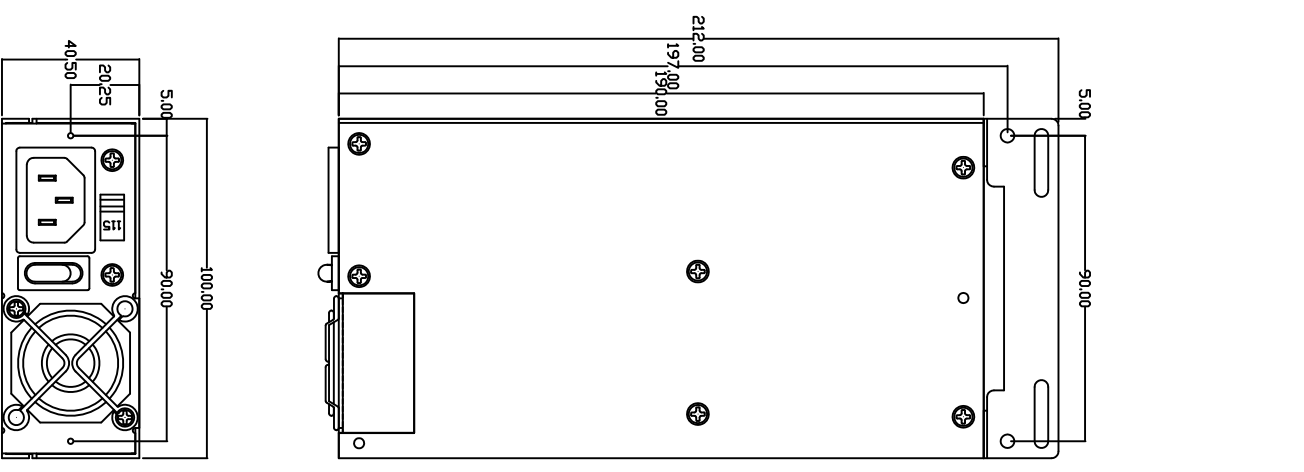

BEST POWER SOLUTION INC.		MTL SPEC: UNSPECIFIED		TOL: S*	
PRD:	SCALE:	APP	0-10	±0.1	
FILE NO:		CHK	10-50	±0.15	
BPS-250S, BPS-300S/1U	TITLE: 1U POWER	DGN	50-150	±0.2	
MODEL:	UNIT: mm	DRV	150-250	±0.25	
	SHEET: 1/1				
	REV: 1				
					Andy