

EM04 - ESM with PowerPC MPC 8245

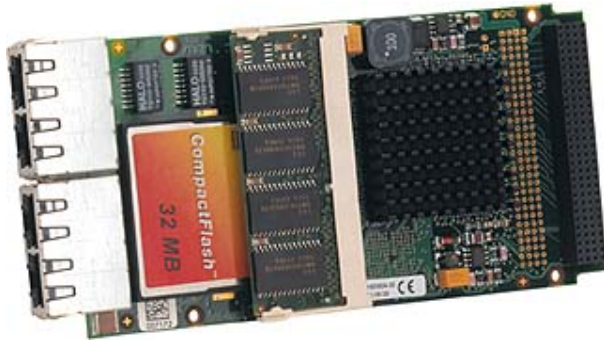

- ◆ **Embedded System Module with:**
- ◆ **PowerPC MPC8245 up to 400 MHz**
- ◆ **Up to 512 MB SDRAM, CompactFlash**
- ◆ **Dual Fast Ethernet, dual COM (front)**
- ◆ **Graphics optional via FPGA (plus 16 MB SDRAM)**
- ◆ **Further COMs, CANopen, IDE etc. optional via FPGA**
(USB, keyboard/mouse, floppy etc. optional on carrier board)
- ◆ **Stackable with PCI-104**

The EM04 is a complete embedded single-board computer for use on any carrier board in different industrial environments. The final application consists either of a stand-alone EM04, the EM04 with an application-specific carrier card and/or with additionally plugged PCI-104 modules.

The EM04 is controlled by an MPC8245 PowerPC (Kahlua II) microprocessor which operates at 266MHz up to 400MHz. The MPC8245 includes a Floating Point Unit and a Memory Management Unit. The EM04 has an SO-DIMM socket for data and a CompactFlash slot for program storage.

At its front panel the EM04 provides two RS232 interfaces and two Fast Ethernet channels. Additionally, nearly unlimited I/O functionality such as graphics controllers, serial interfaces, CAN bus controller etc. can be realized in a very flexible and cost-effective way by means of an onboard FPGA. Physical interfaces for such functions must be implemented on the carrier board.

The EM04 is an ideal computer for low-cost deeply embedded solutions in very harsh environments, for machine control, Man-Machine Interfaces, fieldbus bridges or embedded Linux PCs.

For a first evaluation of the functions of the EM04 it is strongly recommended to use the EK02 ESM starter kit. The kit consists of the standard CPU module, an FPGA loaded with additional I/O functions, the carrier card with I/O connectors, an external PSU, VGA and RJ45 to D-Sub cables, and an adapter for mounting a PCI-104 module.

ESM modules are complete computers on a plug-on module. They consist of the hardware (CPU, chip set, memory, I/O) which is not fixed to any application-specific function, and an FPGA programmed in VHDL code, which provides I/O that is also still independent of a specific application. ESM modules are based on PCI. They have two system connectors: J1 has a fixed signal assignment, while J2 is variable depending on the final application-specific configuration of the ESM and the carrier board. J2 also feeds the I/O signals of the functions programmed in the FPGA to the carrier card.

Technical Data

CPU

- PowerPC
 - MPC8245
 - 266MHz..400MHz

Memory

- Level 1 Cache integrated in MPC8245
- SO-DIMM slot for up to 512MB SDRAM
- 133MHz memory bus operation
- Flash 2MB
 - 8-bit data bus
- Serial EEPROM 4kbit for factory settings
- CompactFlash (TM) card interface for Flash ATA (true IDE) via on-board IDE
- 32MB SDRAM, connected to FPGA, e.g. for video data

Interfaces

- Two 10/100Mbps/s Ethernet channels
 - Intel GD82551 controllers
 - Two RJ45 connectors at front panel
- Two UART RS232 serial interfaces (COM1/COM2)
 - Two RJ45 connectors at front panel
- IDE port for hard-disk drives
 - Available at I/O Connector
 - If implemented in FPGA

I/O options through FPGA

- Available at I/O connector
- All functions optional, depending on FPGA composition
- IDE interface
- SPI interface (e.g. for touch panel control)
- SRAM controller
- Quad UART
- RTS-controlled UART
- CAN interface
- GPIO
- Display control for TFT panels, 800 x 600 pixels, 16-bit color

PCI Interface

- 32-bit PCI interface at PCI-104 connector J1
- Support of 2 external masters

Miscellaneous

- Real-time clock
- Power supervision and watchdog

Electrical Specifications

- Supply voltage/power consumption:
 - +5V (4.85V..5.25V), 340mA typ.
 - +3.3V (3.0V..3.6V), 530mA typ., w/o SO-DIMM; increases up to 1.6A depending on installed SO-DIMM

- MTBF: tbd. @ 50°C

Mechanical Specifications

- Dimensions: conforming to ESM specification (PCB: 149mm x 71mm)
- Weight: 100g

Environmental Specifications

- Temperature range (operation):
 - 0..+60°C or -40..+85°C
 - Airflow: min. 10m³/h
- Temperature range (storage): -40..+85°C
- Relative humidity (operation): max. 95% non-condensing
- Relative humidity (storage): max. 95% non-condensing
- Altitude: -300m to + 3,000m
- Shock: 15g/11ms
- Bump: 10g/16ms
- Vibration (sinusoidal): 2g/10..150Hz

Safety

- PCB manufactured with a flammability rating of 94V-0 by UL recognized manufacturers

EMC

- Tested according to EN 55022 / 1999-05 (radio disturbance) and EN 55024 / 1999-05 (immunity) with regard to CE conformity

Software Support

- MENMON
- Linux (ELinOS)
- VxWorks
- QNX (on request)
- OS-9 (on request)
- CANopen support: MEN Driver Interface System (MDIS for Windows, Linux, VxWorks, QNX, RTX, OS-9)
- MSCAN/Layer2 support: MEN Driver Interface System (MDIS for Windows, Linux, VxWorks, QNX, RTX, OS-9)

Diagram

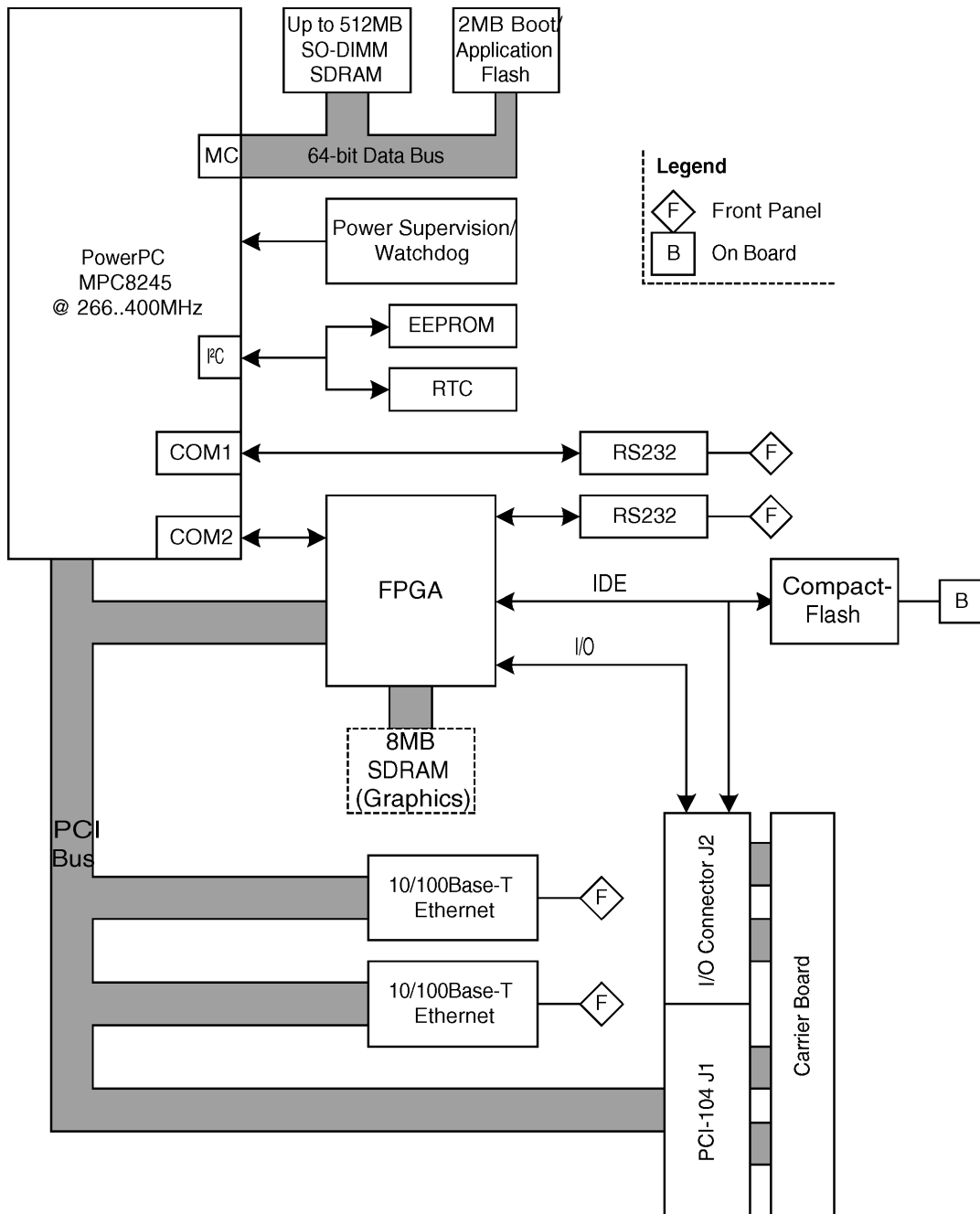

Legend

- ◊ F Front Panel
- B On Board

Related Products

Standard Hardware

08EK02-03	ESM evaluation kit: Mini ATX carrier board EC01 with 1 ESM slot, 3 PCI slots, floppy interface; ESM EM04N with PowerPC Kahlua II / 400MHz, 8MB Flash, 2 Fast Ethernet, 2 COMs, FPGA functions (graphics 800x600, CAN, quad UART, SPI, IDE); temperature range: 0..+60°C; incl. external PSU, RJ45 to D-Sub cable, VGA cable and adapter for mounting of one PCI-104 module - 256MB DRAM installed, CompactFlash not installed (08EK02-03 = EC01-00 + EM04N01)
15EM04N01	EM04N, ESM - Embedded System Module, PowerPC Kahlua II / 400MHz, 2MB Flash, CompactFlash slot, SO-DIMM DRAM slot, dual Fast Ethernet, 2 COMs, FPGA functions (graphics 800x600, CAN, quad UART, SPI, IDE, SRAM, GPIO); PCI-104 stackable; temperature range: 0..+60°C

Please refer to our ESM - Embedded System Modules compare chart for a selection of further single-board computers with different processors and on-board functionality.

Altera offers free download of its FPGA development software: The Quartus II Web Edition software includes a complete environment for FPGA and CPLD design, including schematic- and text-based design entry, integrated VHDL and Verilog HDL synthesis and support for third-party synthesis software, SOPC Builder system generation software, place-and-route, verification, and programming. For more information and free download of the software please refer to www.altera.com/products. The Altera Tools Selector guide describes the Altera tool offerings and requirements. The online version of the document is available at www.altera.com/literature.

Accessories

0751-0006	CompactFlash card, 512MB, Type I, 0..+60°C
0751-0008	CompactFlash card, 64MB, Type I, 0..+60°C
0751-0009	CompactFlash card, 128MB, Type I, 0..+60°C
0751-0012	CompactFlash card, 256MB, Type I, 0..+60°C
0751-0018	CompactFlash card, 256MB, Type I, -40..+85°C
0752-0123	256MB DRAM 0..+60°C for 15EM04N01
0752-0158	512MB DRAM 0..+60°C for 15EM04N01
08SA01-00	Serial interface adapter, RS232, not optically isolated, 0..+60°C
08SA02-00	Serial interface adapter, RS422/485, half duplex, optically isolated, 0..+60°C
08SA02-01	Serial interface adapter, RS422/485, full duplex, optically isolated, 0..+60°C
08SA02-07	Serial interface adapter, RS422/485, full duplex, optically isolated, temperature range: -40..+85°C

Related Products

08SA03-00	Serial interface adapter, RS232, optically isolated, 0..+60°C
08SA03-01	Serial interface adapter, RS232, optically isolated, -40..+85°C
08SA04-00	Serial interface adapter, TTY, optically isolated, 0..+60°C
08SA08-00	Serial interface adapter, CAN ISO high-speed, optically isolated, 0..+60°C

Software

10ABMX-20	ElinOS V.3.0 - Embedded Linux incl. RTAI real-time extension for PowerPC, English version. The Sysgo Development Kit includes the board support packages (BSPs) for MEN cards F1N, B11, A12, A15, D3, SC13, F6, EM04/N and PP01. The package includes 1 year ElinOS development support and all ElinOS updates and upgrades during this period for free. It additionally includes the BSP support for MEN hardware by MEN. --- N.B.: For correct handling of the ElinOS software support it is mandatory to sign and return the enclosed support agreement directly to Sysgo! The Sysgo support agreement is automatically prolonged for another year if not cancelled 3 months prior to expiration.
10ABMX-21	ElinOS V.3.0 - Embedded Linux incl. RTAI real-time extension for PowerPC, German version. The Sysgo Development Kit includes the board support packages (BSPs) for MEN cards F1N, B11, A12, D3, SC13, F6, EM04/N and PP01. The package includes 1 year ElinOS development support and all ElinOS updates and upgrades during this period for free. It additionally includes the BSP support for MEN hardware by MEN. --- N.B.: For correct handling of the ElinOS software support it is mandatory to sign and return the enclosed support agreement directly to Sysgo! The Sysgo support agreement is automatically prolonged for another year if not cancelled 3 months prior to expiration.
10EM04-60	VxWorks Tornado 2.0.2..2.2.1/VxWorks 5.4 .. 5.5.1 BSP for EM04 and EM04N

This board is an MEN product running Sysgo's ElinOS Embedded Linux. Sysgo provides full support for MEN hardware. Please contact www.sysgo.de.

MEN has vast experience with CANopen-based implementations on standard and custom boards and systems. The CANopen protocol stack on MEN solutions runs under Windows, Linux, VxWorks, QNX, OS-9 and other software environments. You will find more information about CANopen under www.can-cia.org/canopen.

13Z015-06	MDIS4/2004 low-level driver sources for MSCAN/Layer2
13Z016-06	MDIS4/2004 low-level CANopen driver (Master)
14EM04-00	MENMON (Firmware) for EM04, EM04N (object code)

Documentation

20EK02-00	EK02 user manual
-----------	------------------

Related Products

20EM04-00	EM04/EM04N user manual
21APPN004	Application Note: ELinOS demo-em04-001, simple demo project for EM04
21APPN005	Application Note: ELinOS demo-em04-000, X-Window/RTAI demo project for EM04
21APPN006	Application Note: ELinOS demo-em04-002, simple demo project for EM04

For the most up-to-date ordering information and direct links to other data sheets and downloads, see the EM04 online data sheet under www.men.de. --> [Click here!](#)

Germany

MEN Mikro Elektronik GmbH
Neuwieder Straße 5-7
90411 Nuremberg
Phone +49-911-99 33 5-0
Fax +49-911-99 33 5-901
E-mail info@men.de
www.men.de

France

MEN Mikro Elektronik SA
18, rue René Cassin
ZA de la Châtelaine
74240 Gaillard
Phone +33 (0) 450-955-312
Fax +33 (0) 450-955-211
E-mail info@men-france.fr
www.men-france.fr

UK

MEN Micro Ltd
Whitehall, 75 School Lane
Hartford, Northwich
Cheshire UK, CW8 1PF
Phone +44 (0) 1477-549-185
Fax +44 (0) 1477-549-178
E-mail info@menmicro.co.uk
www.menmicro.co.uk

USA

MEN Micro, Inc.
PO Box 4160
Lago Vista, TX 78645-4160
Phone (512) 267-8883
Fax (512) 267-8803
E-mail sales@menmicro.com
www.menmicro.com

The date of issue stated in this data sheet refers to the Technical Data only. Changes in ordering information given herein do not affect the date of issue. All brand or product names are trademarks or registered trademarks of their respective holders.

Information in this document has been carefully checked and is believed to be accurate as of the date of publication; however, no responsibility is assumed for inaccuracies. MEN Mikro Elektronik accepts no liability for consequential or incidental damages arising from the use of its products and reserves the right to make changes on the products herein without notice to improve reliability, function or design. MEN Mikro Elektronik does not assume any liability arising out of the application or use of the products described in this document.

The products of MEN Mikro Elektronik are not suited for use in nuclear reactors and for application in medical appliances used for therapeutical purposes. Application of MEN's products in such plants is only possible after the user has precisely specified the operation environment and after MEN Mikro Elektronik has consequently adapted and released the product.

Copyright © 2004 MEN Mikro Elektronik GmbH. All rights reserved.