

# DPX<sup>®</sup>-S Series Enclosures

Industrial Enclosures For Gaming Applications



## Features

- Rugged off-the-shelf enclosure
- Compatible with DPX<sup>®</sup>-S Series motherboards
- Very compact size
- Security and cooling included
- Options for high performance graphics cards



## Introduction

Advantech-Innocode offers a range of low cost, high quality enclosures for our gaming board products. The new S Series enclosures can be used with any of Advantech-Innocode's advanced DPX<sup>®</sup>-S Series system boards creating an attractive all-in-one industrial gaming platform. The enclosures include a secure locking mechanism, intrusion switches wired to the motherboard's security system and a robust cooling system. They also include all internal cable harnessing and options for various peripherals such as solid state drives, CF cards, SATA DOMs, graphics cards and Dallas™ iButton<sup>®</sup>.

## Feature Summary

System	Enclosures for the range of Advantech-Innocode DPX <sup>®</sup> Series gaming boards
	Powder coated extruded aluminium construction
	Internal cables
	Cooling fan
	Security lock
	Intrusion detection switch
	Full assembly, functional test and burn-in
	External universal switching ATX power supply (available separately)
I/O	Access to all the I/O of the respective system board platform
Video	Optional graphic cards (depending on motherboard)
Options	iButtons <sup>®</sup>
	Compact Flash modules
	SATA DOM
	Solid state flash drives (SSD)

## Benefits

Ready made attractive enclosure solutions
Fast time to market
Designed for the gaming industry
Meets regulatory standards
Low cost

## DPX<sup>®</sup>-S Series Enclosures

Available with the following motherboards	DPX <sup>®</sup> -S410 DPX <sup>®</sup> -S305 DPX <sup>®</sup> -S Series future products See motherboard documentation for detailed individual features.
Dims (mm)	92 (H) x 250 (W) x 184mm (L) (front to back) main unit 92 (H) x 250 (W) x 238mm (L) including feet and fan
PSU	180W min. external ATX (available separately)
Operating	Temperature 0 - 40° C
	Mounting Four feet drilled M4 holes

Front View

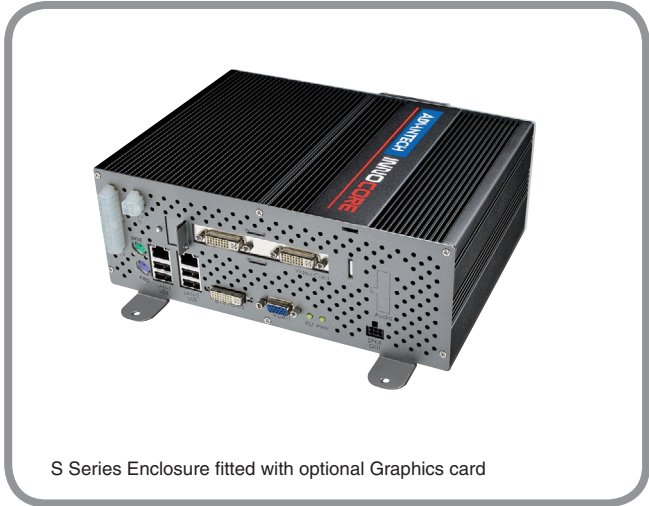

S Series Enclosure fitted with optional Graphics card

Rear View



Golden Finger Connector. See motherboard datasheet for specifications.

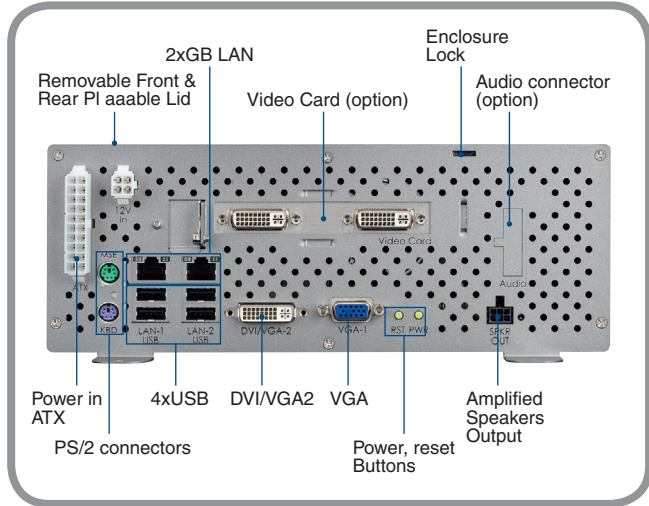

OEM Customization and Product Development

- Advantech-Innocore specializes in the fields of PC-based hardware design and software development. Our in-depth knowledge and global resources make us your ideal partner.
- Advantech-Innocore is part of the Advantech Co., Ltd. Group of Companies.
- Specifications subject to change. E&OE.
- Copyright © 2011 Advantech Co., Ltd.
- All rights reserved. Advantech-Innocore, the Advantech-Innocore Logo, DPX, ConnectBus are trademarks of Advantech Co., Ltd. in the UK, US and other countries.
- All other trademarks are acknowledged and respected.