

Cheetah-Cr

CompactPCI Pentium® M Single Board Computer

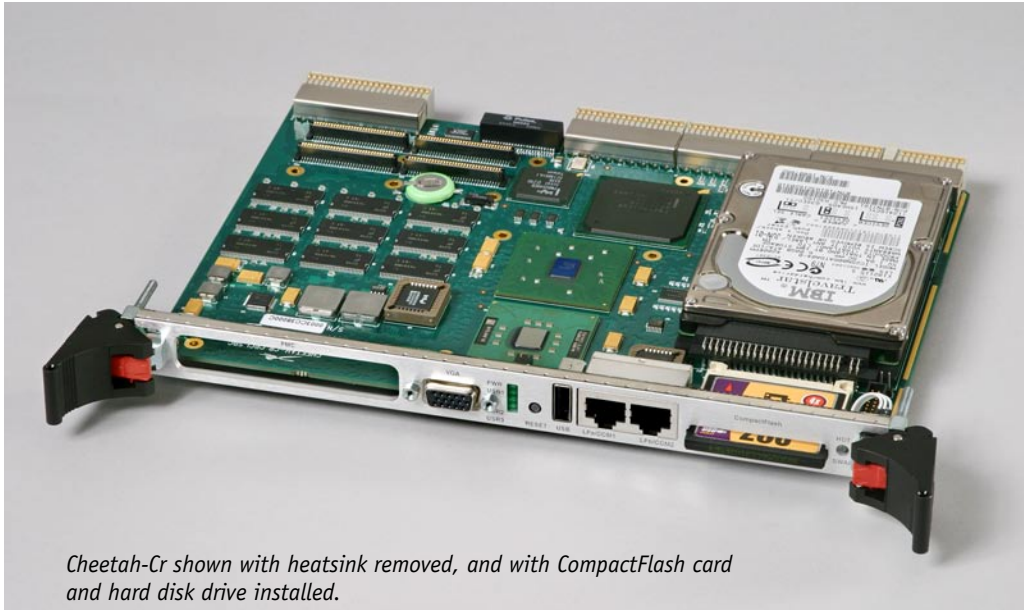

momentum
COMPUTER



Cheetah-Cr shown with heatsink removed, and with CompactFlash card and hard disk drive installed.

**High Performance
Pentium M processor,
Gigabit Ethernet via
PICMG 2.16**

FEATURE SET:

- Intel Pentium M Processor running at 1.1 GHz or 1.6 GHz core frequency and 400 MHz Processor System Bus frequency.
- Single slot 6U CompactPCI board.
- Operates in a CompactPCI system slot or non-system slot (auto-senses).
- Intel 855GME Memory Controller Hub with built-in 3D graphics engine.
- Universal Transparent/Non-Transparent PCI-X to PCI-X bridge interfaces to 32-bit or 64-bit CompactPCI bus operating at 33 MHz or 66 MHz (PICMG 2.0 R3.0).
- Hot Swappable (PICMG 2.1 R2.0).
- Three user LEDs on the front panel.
- Windows® 2000/XP, FreeBSD, Linux, VxWorks Operating Systems.
- 0-55°C operating temperature (ambient).

MEMORY AND STORAGE:

- Up to 2 Gbyte of DDR333 SDRAM with ECC at 2.667 Gbyte/s peak bandwidth.
- Type I/II CompactFlash socket accessible from the front panel.
- 1 Mbyte Firmware Hub.
- Battery backed Real Time Clock.

The Momentum Computer Cheetah-Cr is an Intel Pentium® M processor based CompactPCI Single Board Computer, in a 6U form factor, operating at 1.1 or 1.6 GHz.

The board incorporates the Intel 855GME memory controller that supports a 400 MHz processor bus and single channel unbuffered DDR333 SDRAM with ECC. An Intel 6300ESB I/O Controller Hub handles the extensive I/O capability of the Cheetah-Cr.

Two 10/100/1000Base-T Ethernet ports are provided at either a front panel dual RJ45 connector or the backplane J3 connector as PICMG 2.16 nodes. Two IPMB interfaces are also provided on the backplane J1 and J2 connectors for PICMG 2.9 compliance.

The board auto-senses and operates as a CompactPCI system board or non-system board.

The Cheetah-Cr provides a wide range of I/O and storage interfaces through front panel and backplane J5 connectors. A 64-bit 66/33 MHz PMC site is included for onboard I/O expansion. A 32-bit 33 MHz PCI interface is also included on the backplane J5 connector for rear I/O expansion. There is also a Type I/II CompactFlash® socket on the front panel.

For especially cost sensitive application, the Cheetah-Cr is also available with a 1.30 GHz Intel Celeron® M processor.

VERSATILE I/O:

- One 64-bit 66/33 MHz PCI/PCI-X PMC site (IEEE P1386/P1386.1).
- 16-bit 1.066 Gbyte/s Hub 2.0 interface on backplane J5 for high speed rear I/O expansion.
- On-board 2.5" ATA-100 HDD.
- HD-15 VGA interface on the front panel.
- PMC interface with I/O accessible from the backplane J3 connector.
- 32-bit 33 MHz PCI interface on backplane J5 for I/O expansion.
- Two 10/100/1000Base-T Ethernet links available either through backplane J3 (PICMG 2.16) or front panel dual RJ45 Connector.†
- Serial ATA150 interface on backplane J5.
- Four serial ports: two on backplane J5 and two on the front panel through RJ11 cable.†
- Two IPMB interfaces on backplane J1 and J2 (PICMG 2.9).
- Three USB 2.0 ports, one on the front panel, two on the backplane J5 connector.

† Manufacturing option. For PICMG 2.16 configuration, the front panel RJ45 connector is used as RJ11 cable interface for COM1 and COM2 access.

Cheetah-Cr

CompactPCI Pentium® M Single Board Computer

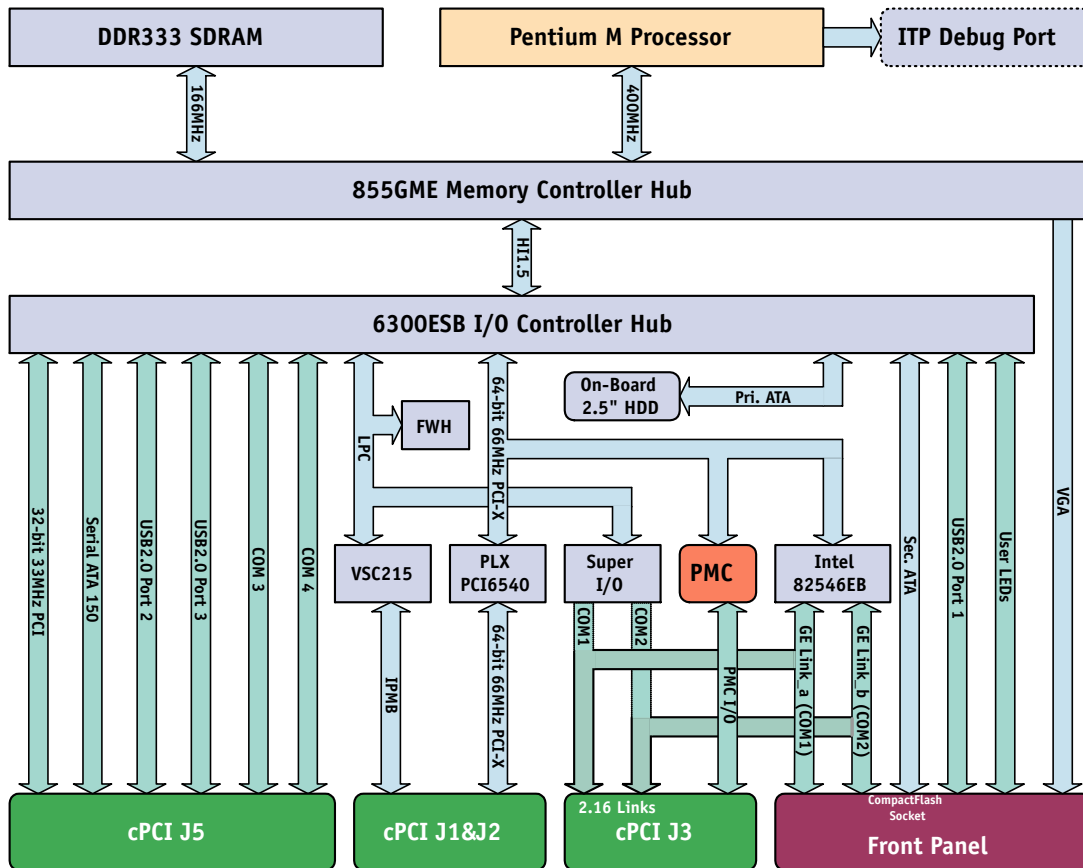

If Cheetah-Cr doesn't fit your specific requirements:
Momentum Computer specializes in quick turn custom development and production of high performance processor boards and I/O boards.
Custom designs give you a competitive edge by providing the unique features needed for a leading market position.
Custom designs by Momentum Computer are accomplished so rapidly that time-to-market targets can be met with confidence.

We're ready to work for you.



Momentum Computer, Inc.

1815 Aston Avenue, Suite 107, Carlsbad, CA 92008-7310

Tel: 760.431.8663 • Fax: 760.431.7571 • e-mail: info@momenco.com

www.momentum-computer.com