

Volt-Pac Variable Autotransformer



Product Features

Voltage Regulators

- 99% Efficiency.
- $\pm 1\%$ Output accuracy.
- No distortion or harmonics.
- Single & 3 phase, 120-480V models.
- 1.5 Through 500 KVA sizes.
- Analog or digital control.
- Single or three line control.
- Insensitive to Load power factor.

Variable Transformers

- Single and poly phase models.
- Manual and motor driven models.
- Programmable digital control option.
- Open or enclosed construction.
- 99% Efficiency.
- 2.5 to 300 Amp capacity.
- 120, 240 & 480V models.
- Formerly manufactured by GE.

Table of Contents

PRODUCT OVERVIEW	1
GENERAL PERFORMANCE INFORMATION	2
MANUAL, SINGLE-PHASE UNITS	4
MANUAL, THREE-PHASE UNITS	5
MOTORIZED, SINGLE-PHASE UNITS	6
MOTORIZED, THREE-PHASE UNITS	7
TERMINAL ARRANGEMENTS, CONNECTIONS AND WIRING	8
TERMINAL COVER KITS / MOTOR OPERATING TIMES	9
AUTOMATIC VOLTAGE REGULATORS	10
CONTROLLER	12
DIMENSIONS	13

WARRANTY: All Weschler Instruments products are warranted against material defects and workmanship for a period of one (1) year from date of manufacture.

OPTIONS AND FEATURES MAY VARY BETWEEN MODELS, CONTACT FACTORY FOR SPECIFICS. IN A CONSTANT EFFORT TO IMPROVE OUR PRODUCTS, SPECIFICATIONS MAY CHANGE FROM THOSE PUBLISHED.

CROSS REFERENCE TO MOST POPULAR COMPETITORS PRODUCTS

STACO	SUPERIOR	WESCHLER
221-B 501 1010	10C 21 116CU	9T92A1 9T92A9 9T92A9
1020 1510 1520	216U 126U 226U	9T92A13 9T92A28 9T92A30
5010 5020 6010 6020 ----- -----	1156DU 1256DU ----- 1296DU 146U 246U	9T92A49 9T92A51 9T92A50 9T92A52 9T92A38 9T92A40

Volt-Pac Variable Autotransformer

PRODUCT OVERVIEW

The Volt-Pac variable transformer provides continuously adjustable voltage over a range of zero to either 100% or 117% of the line voltage. Its operation is simple and efficient, and is based on autotransformer action.

The Volt-Pac coils are precision wound on a toroidally-shaped core. One face of the winding is properly smoothed and gold plated to provide a low resistance and long wearing track for the carbon brush. This plating process has been developed to provide efficient mating of brush and brush track for improved reliability of operation under severe operating conditions. Operating life has been substantially improved as a result. The core consists of strip-wound silicon steel for low electrical losses. The coil is insulated from the core by means of a molded phenolic form.

To aid in heat dissipation a thermal radiator is mounted to, but electrically insulated from the shaft. This thermal radiator also serves as a brush holder.

DESCRIPTION

Manual and motor-operated Volt-Pac models are listed in this publication. Manual units provide fingertip voltage control when the Volt-Pac is easily accessible; use the motor-operated type for remote and automatic control or for large power ratings inconvenient to operate by hand. Rounding out the complete Volt-Pac line, automatic Volt-Pac models can be furnished to provide closely regulated output voltages.

Manual and motorized Volt-Pacs can be furnished in either uncased or cased construction. Cased 50, 60 and 75 frame single and multi-coil units are supplied with terminals exposed. Terminal enclosure kits listed on page 9 may be purchased separately. Cased 85 and 95 frame units are supplied fully enclosed in a NEMA 1 rated enclosure. The general configuration of Volt-Pac models will vary depending upon the number of cores and how they are stacked together to achieve different ratings.

UL-recognized insulation systems have been used throughout. In addition, UL component listings are applicable to many of the models identified on the following pages.

NO WAVEFORM DISTORTION

Volt-Pac variable transformers provide an output voltage waveform that is a precise reproduction of the applied input waveform.

Many other types of voltage control devices (such as phase-control semiconductors and saturable reactors) introduce distortion of the voltage waveform. For detailed appli-

cation information regarding waveform characteristics and Volt-Pac transformers, see the "waveform distortion" discussion on page 2.

Cut-a-way view of 60-frame Volt-Pac variable transformer.

APPLICATION

Volt-Pacs are presently at work on many electronic and electrical applications including:

- Power supplies
- Laboratory instruments
- Test equipment
- Speed control devices
- Computer peripheral equipment
- Welding controls
- High-voltage precipitators
- Variable speed devices for large machinery
- Electroplating
- High-voltage electronic tube circuits

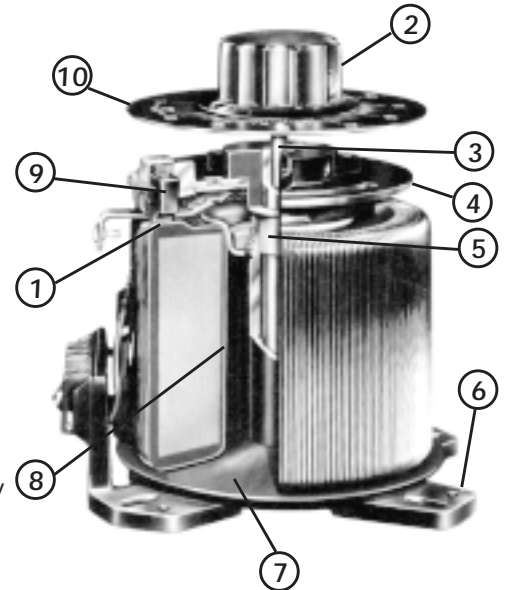

- 1 - New unique plating process on brush tracks results in long life operation. This ultra reliable feature is now furnished on all models.
- 2 - Output voltage selector.
- 3 - Standard steel shaft is easy to replace or modify.
- 4 - Aluminum radiator dissipates heat, protects brush track.
- 5 - Self-lubricating nylon bearings for smooth, reliable rotation.

- 6 - Cast-aluminum base for maximum heat dissipation provides easy surface or back-of-panel mounting.
- 7 - Insulation between core-and-coil and metallic base.
- 8 - Precision bank-wound coils.
- 9 - Spring-loaded solid-carbon brush.
- 10 - Dial plate fits on shaft and provides reference for voltage selection.
- 11 - Corrosion-resistant parts used throughout.

MILLION OPERATION TEST PROVIDES RELIABILITY

With a minimum of moving parts, Volt-Pac variable transformers are virtually maintenance-free. At the point of critical contact, where the carbon brush travels on the coil surface, extra reliability is built in to assure long-life operation.

Starting with precision wound coils (wound under constant tension) a smooth surface is provided for the brush track. Critical tolerances are maintained during this process, a 0.001 in. error results in a reject! On the track area, epoxy cement is added. The coil is then oven-cured. Results are, each length of wire is immobilized, locked firmly in position to provide rigid permanence and electrical reliability.

Then the brush track is smoothed to a gem-like finish on a lapping machine. This lapping process exposes the surface of each

copper conductor to a prescribed depth, resulting in a uniformly flat, polished area on which the carbon brush travels.

The polished surface is thoroughly cleaned prior to plating to assure maximum "take" of the gold alloy plating process. Gold alloy is used to provide a low resistance, nonoxidizing surface which prevents overheating and associated burnout problems.

Over this durable, ultra-smooth surface, rides a spring-loaded, grain-oriented solid carbon brush. The contact between surfaces is so precise that laboratory tests show over one-million operations result in brush wear of less than 0.01 in.

When you specify Volt-Pac variable transformers, you're getting precision equipment designed for maximum life with minimum maintenance.

Volt-Pac Variable Autotransformer

General Performance Information

OUTPUT VOLTAGE RANGE

Most Weschler Instruments Volt-Pac variable transformers can be connected to adjust output voltage as a percent of input voltage over a range of either 0 to 100% or 0 to 117%. Refer to page 8 for connection details.

However, when using units connected for 0 to 117% range, rated amperes (as shown in the product listings on pages 4-7 must not be exceeded.

INPUT VOLTAGE TAP

Many 240 and 480 volt input units are equipped with a tap for use on 120 or 240 volt lines while maintaining rated output voltage, i.e., 0-280 or 0-560 volts. However, when operating Volt-Pac units on the lower input voltage tap, rated current must be reduced in accordance with Curve 1 below when output voltage exceeds 140 percent of input voltage.

For example, model 9T92A40, having rated current of 16 amps, must not draw more than 11.5 amps (72 percent x rated current) when operating at 200 volt output with 120 volt input.

CURVE 1. Current must be derated as shown when operating 240-volt units on 120V tap or 480V units on 240V tap.

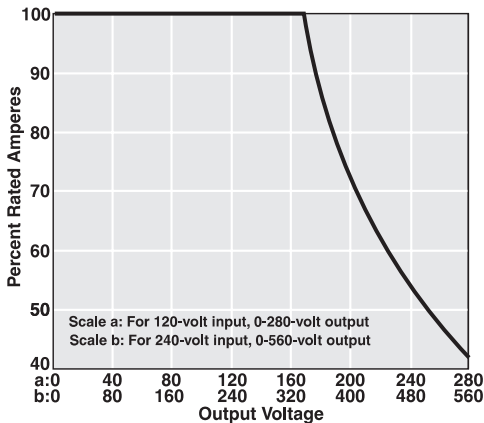

RATED AND MAXIMUM AMPERES

Rated amperes is the output current that can be drawn from the Volt-Pac transformer at any position of the output voltage selector, with either line (0-100%), or over-voltage (0-117% output) connections.

Note that rated current is maintained with minimum resistance between track and brushes and is dependent on periodic movement of the brushes. Leaving the brushes in one spot for extended periods will gradually increase contact resistance and may result in eventual overheating and damage to the Volt-Pac unit.

Maximum amperes is the output current which can be safely drawn only when the output voltage selector is at the full-range position and connected for line voltage output. Maximum amperes must be decreased proportionately as output voltage is decreased until rated current is reached. As shown in Curve 2, any value of current in the shaded area may be safely drawn. NOTE: maximum amperes must not be drawn on over-voltage connections.

Maximum amperes capability is most significant when the load has constant impedance; that is, when the output current automatically decreases in proportion to the voltage applied-- such as with resistive loads.

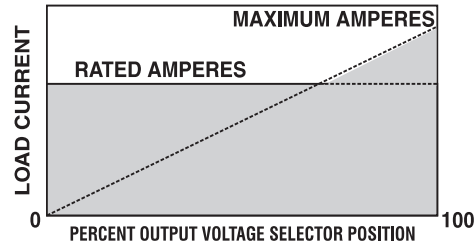

CURVE 2. Maximum amperes must be decreased linearly with output voltage until rated amperes is reached.

OVERLOAD CAPACITY

Volt-Pac transformers have the capacity to handle non-repetitive short-duration overload currents as shown in Curve 3.

For example, any Volt-Pac unit can safely withstand 250 percent rated current for five minutes, as long as this condition is not repetitive.

CURVE 3 - Short-duration overload.

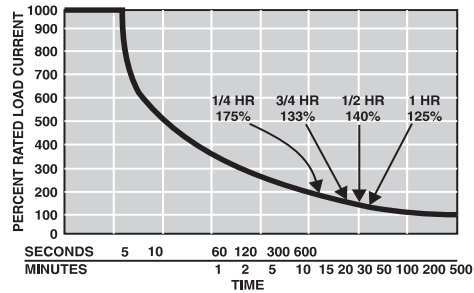

KVA RATINGS

KVA is a common term of rating for transformers with fixed outputs. However, on variable voltage devices such as the Volt-Pac, the KVA varies as the output voltage is changed; consequently, no single KVA rating is definitive. Therefore, Volt-Pac transformer listings are presented in terms of current and voltage rating separately.

WAVE-FORM DISTORTION

Volt-Pac variable transformers, being unsaturated magnetic components, do not introduce wave-form distortion. With Volt-Pac transformers, the output voltage waveform is a precise reproduction of the applied input wave-form. This is true for both single and three phase units.

REGULATION (60-HERTZ)

Volt-Pac transformers provide excellent load regulation, with very small changes in output voltage occurring from no load to full load. Curve 4 enables you to find the percent regulation factor for any of the three basic type of Volt-Pac transformer connections. This percent factor, times the appropriate "regulation volts" from Table A, at right, gives the output voltage drop for any Volt-Pac transformer model number.

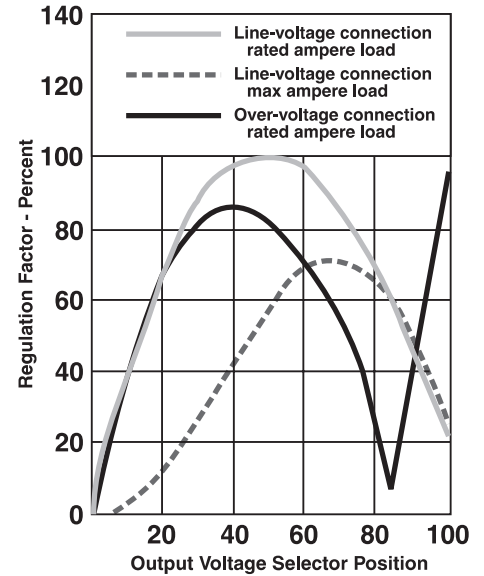

CURVE 4. Chart used to determine regulation factor in percent.

CALCULATING REGULATION

To determine the regulation of any Volt-Pac transformer application, follow this simple three-step approach:

1. DETERMINE REGULATION FACTOR IN PERCENT-- Establish, in percent, the position of the output voltage selector in relation to its full rotation. Start with this point on the bottom of the curve representing the Volt-Pac connection you are using. At the point of intersection, read directly left and identify the regulation factor in percent.

Example: Volt-Pac transformer is set at the 80 percent output voltage selector position with 0-100% range connection. Read up from 80 percent until you intersect the solid colored curve. Read left to the regulation factor which is 69 percent.

2. DETERMINE REGULATION VOLTS

Determine proper rated current for the Volt-Pac from model number listings on pages 4 - 7. From Table A and this current rating, determine "regulation" volts.

Example: You are applying Model Number 9T92A10. The product listing shows rated amperes to be 12.0. Matching 12.0 amps with "regulation" volts in Table A, you get 2.3 volts.

TABLE A "REGULATION" VOLTS BY RATED AMPERES

120V, 1-phase 240V, 3-phase		240V, 1-phase 480V, 1 & 3 phase	
Rated Amperes	"Regulation" Volts	Rated Amperes	"Regulation" Volts
2.5	8.0	4.0	11.0
4.5	6.0	5.0	9.5
6.5	5.0	7.0	5.25
10.0	2.8	8.5	8.25
12.0	2.3	14.0	7.5
15.0	2.25	16.0	10.5
18.0	3.0	30.0	12.0
30.0	3.0	35.0	16.0
37.0	4.0		
50.0	6.8		
60.0	9.5		

Volt-Pac Variable Autotransformer

General Performance Information

TABLE A NOTES:

On model numbers having rated amps greater than shown on chart, convert to chart values as follows :

120 VOLT, 1-PHASE—divide rated amps by number of cores.

240 VOLT, 3-PHASE—divide rated amps by 1/3 the number of cores.

240 VOLT, 1-PHASE—divide rated amps by number of cores.

480 VOLT, 1-PHASE—divide rated amps by 1/2 number of cores.

480 VOLT, 3-PHASE—divide rated amps by 1/3 number of cores.

3. MULTIPLY REGULATION VOLTS BY PERCENT FACTOR. The 2.3 volts in Step 2, multiplied by the "regulation" factor of 69 percent from Step 1, indicates a 1.6 volt drop in output voltage when output current changes from zero to full load at the specified 80% selector position.

AMBIENT TEMPERATURE

Volt-Pac transformer models are designed for continuous operation in ambients of -20°C to 40°C , at full rated load. When operated above 40°C , units must be derated in accordance with Curve 5. For example, when operating model 9T92A5 in a 60°C ambient, rated amperes would be: $87\% \times 4.5 = 3.92$. Maximum amperes would be: $87\% \times 5.8 = 5.05$.

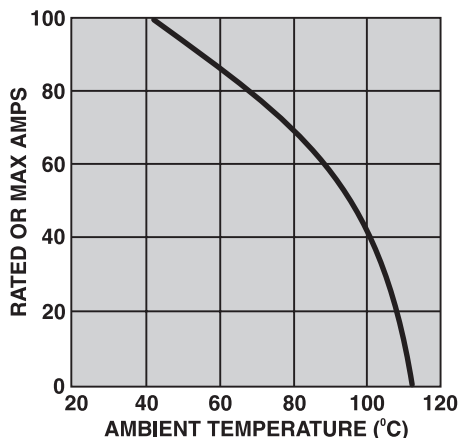

CURVE 5

Chart for ambients above 40°C , Volt-Pac variable transformers should be derated in accordance with this curve.

FREQUENCY

With the exceptions noted in the Model Number listings on pages 4-7, all Volt-Pac variable transformers are designed for operation at 50/60 Hz. They may be operated at higher frequencies, without derating, however regulation becomes poorer. Units listed for 240-volt operation may be applied on 120-volt, 25-Hz. supplies at listed current ratings using 240-volt line connections.

LINEAR OUTPUT VOLTAGE

Compared with other adjustable voltage control devices, Volt-Pac transformers have

the advantage of providing output voltage which varies linearly in proportion to the angle of rotation of the output voltage selector. Because of the large number of increments of output voltage selection, the output voltage is virtually stepless.

HIGH EFFICIENCY

Volt-Pac variable transformers have low electrical losses under all load conditions. Efficiency is 98.5 percent when the output voltage selector is at full rotation. This efficiency remains high, even at greatly reduced load voltage. The efficiency curve (CURVE 6) is typical for all Volt-Pac transformer ratings, including 240 and 480-volt ratings.

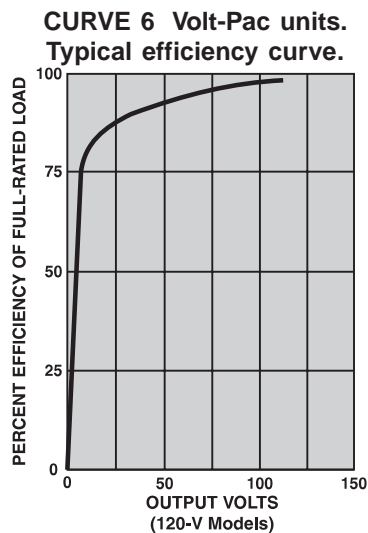

THREE-PHASE CONNECTIONS

Volt-Pac transformers rated for three-phase circuits are suitable for connection to either delta or wye connected incoming power sources or loads. These three-phase models consist of multiples of two or three single-phase units electrically connected in wye or open delta. Wye connected units have a neutral connection accessible. A common shaft rotates the output voltage selector of all the component core and coils in unison. Wye connected Volt-Pac transformers can be used to feed 3-wire, 3-phase balanced loads. However, the common connection (or "neutral") of the Volt-Pac unit must not be used. This also applies if the system input is 3-wire, 3-phase (delta) with midpoint connection in one of the phases.

With a three phase, 4-wire system input, the system neutral should be solidly connected to the common or "neutral" point of the Volt-Pac unit. This will prevent neutral shift and possible damage or failure of the unit. Full-range voltage control cannot be obtained from a three-phase Volt-Pac unit consisting of three single-phase units connected in closed delta. Outside the factory, it is not practical to convert multiple single-phase models to balanced three-phase applications because of associated mechanical problems.

POWER FACTOR

Load power factor has very little effect on the operation of a Volt-Pac transformer in the range from 0.5 lagging to 0.5 leading. Like any transformer, the Volt-Pac reflects the load power factor to the line with very little change. Only for very light loads, possibly under 10%, will the lagging power factor of the Volt-Pac become significant.

SERIES AND PARALLEL CONNECTIONS

Single-phase Volt-Pac transformers are not suitable for series or parallel connection in the field because of the problems associated with field-adaption of single-phase units for common shaft operation. (Common shaft operation is required to prevent unbalanced loads and circulating currents.) Even factory models, with common shaft operations, and parallel connected coils, are provided with intercoil reactors to minimize circulating currents.

OPTIONS

FUSES-You may wish to fuse the brush lead (lead No. 3) of your Volt-Pac transformer for the maximum current rating applicable to your model. This is good practice and protects the Volt-Pac unit against unforeseen overloads.

TAPS-Fixed-voltage taps can be provided at specific voltage levels depending on frame size and rated voltage. Such taps may require derating of the variable power output of the Volt-Pac unit to stay within the total power rating of the unit.

SHAFT MODIFICATIONS-The shaft provided with each model accommodates the Volt-Pac transformer's voltage selector knob when mounted on panels not exceeding the thickness shown in dimension data. Modification to the shaft, either in length or end-diameter, is available for both manual and motor-operated units.

MECHANICAL STOPS (MANUAL UNITS ONLY)-Mechanical stops are special additional clamps which can be provided to confine the angle of rotation of the voltage selector to a portion of the total travel. The additional mechanical stops establish a minimum output voltage above zero, and a maximum output voltage below rated.

POSITIONING POTENTIOMETER-A precision potentiometer can be mounted on an extended shaft of the Volt-Pac unit and can be used to reflect a signal proportional to the angle of rotation of the output voltage selector. Such a potentiometer is normally used in the bridge circuit of a controller.

LIMIT SWITCHES-All Weschler motor-operated Volt-Pac transformers have a limit switch at each end of the winding to prevent over-travel of the voltage selector. Manual Volt-Pac units have mechanical stops to provide the same function. All Volt-Pac transformers can be provided with additional limit switches to actuate other control circuitry at predetermined positions (or specified lengths of travel) of the output voltage selector.

Volt-Pac Variable Autotransformer

MANUAL, SINGLE-PHASE

The manual Volt-Pac transformer is one of three types of Volt-Pac variable transformers offered by Weschler Instruments. It is a device to provide continuously adjustable voltage to an electrical load from a fixed line voltage. Its operation is simple and is based on autotransformer action.

For information about motor-operated Volt-Pac units, see pages 6-7.



Line Voltage (0-100%) or Over Voltage (0-117%) Connection ¹ Rated Amperes	Line Voltage (0-100%) Connection Only Max. Amperes (For Constant Impedance Loads)	No. of Cores & Frame Size	UNCASED MODELS	CASED MODELS	Foot Notes	OUTLINE DIMENSIONS		Approx. Net Wt. Lb.	
			Model No.	Model No.		Uncased Fig. No. See pages 13,14	Cased Fig. No. See pages 13-17	Uncased	Cased

120 VOLT INPUT: OUTPUT 0-120 VOLT (LINE VOLTAGE CONNECTION) 0-140 VOLT (OVERVOLTAGE CONNECTION)

2.5	3.2	1-30	9T92A1	-----	3, 9	1	1	2	-----
6.5	8.0	1-50	9T92A7	9T92A7G2	2, 3, 9, 10	3	3	7 1/2	8 1/2
10.0	11.5	1-60	9T92A9	9T92A9G2	9, 10	4	4	10	11
12.0	14.5	1-60	9T92A10	9T92A10G2	5, 6, 9, 10	4	4	10	11
15.0	19.0	1-75	9T92A27	9T92A27G2	2, 10	5	5	15	17
18.0	21.7	1-75	9T92A28	9T92A28G2	2, 10	5	5	15	17
30.0	34.0	1-85	9T92A37	9T92A37G2	2, 10	6	6	30	33
34.0	37.0	1-85	9T92A38	9T92A38G2	2, 10	6	6	30	33
50.0	55.0	1-95	9T92A49	9T92A49G4	-----	7	36A	58	73
60.0	60.0	1-95	9T92A50	9T92A50G4	-----	7	36A	60	75
68.0	74.0	2-85	9T92A41	9T92A41G2	2	8	8	67	73
100.0	110.0	2-95	9T92A53	9T92A53G4	-----	9	36B	140	202
120.0	120.0	2-95	9T92A54	9T92A54G4	-----	9	36B	145	218
150.0	165.0	3-95	9T92A55	9T92A55G4	-----	11	36C	200	265
200.0	220.0	4-95	9T92A56	9T92A56G4	-----	11	36C	265	335
250.0	275.0	5-95	9T92A57	9T92A57G4	9	11	36E	325	395
300.0	330.0	6-95	9T92A58	9T92A58G4	-----	11	36E	390	410
360.0	360.0	6-95	9T92A59	9T92A59G4	-----	11	36E	402	435

240 VOLT INPUT: OUTPUT 0-240 VOLT (LINE VOLTAGE CONNECTION) 0-280 VOLT (OVERVOLTAGE CONNECTION) OR 120-VOLT INPUT: OUTPUT 0-280 VOLT (Note 4)

4.0	5.0	1-60	9T92A13	9T92A13G2	9, 10	4	4	10	11
5.0	6.8	1-60	9T92A14	9T92A14G2	6, 9, 10	4	4	10	11
7.0	10.1	1-75	9T92A29	9T92A29G2	2, 10	5	5	15	17
8.5	11.0	1-75	9T92A30	9T92A30G2	2, 10	5	5	15	17
12.0	14.5	2-60	9T92A23	9T92A23G2	5, 6, 10	13	13	22	23 1/2
14.0	14.0	1-85	9T92A39	9T92A39G2	2, 10	6	6	30	33
16.0	16.0	1-85	9T92A40	9T92A40G2	2, 10	6	6	30	33
30.0	33.0	1-95	9T92A51	9T92A51G4	-----	7	36A	58	73
35.0	35.0	1-95	9T92A52	9T92A52G4	-----	7	36A	60	75
60.0	66.0	2-95	9T92A60	9T92A60G4	-----	9	36B	140	202
90.0	99.0	3-95	9T92A62	9T92A62G4	-----	11	36C	200	265
120.0	132.0	4-95	9T92A63	9T92A63G4	-----	11	36D	265	335
150.0	165.0	5-95	9T92A64	9T92A64G4	-----	11	36E	325	390
180.0	198.0	6-95	9T92A65	9T92A65G4	-----	11	36E	390	460
210.0	210.0	6-95	9T92A66	9T92A66G4	-----	11	36E	402	475

480 VOLT INPUT: OUTPUT 0-480 VOLT (LINE VOLTAGE CONNECTION) 0-560 VOLT (OVERVOLTAGE CONNECTION) OR 240-VOLT INPUT: OUTPUT 0-560 VOLT (Note 4)

4.0	5.0	2-60	9T92A17	9T92A17G2	2	13	13	22	23 1/2
5.0	6.8	2-60	9T92A18	9T92A18G2	6	13	13	22	23 1/2
7.0	10.1	2-75	9T92A31	9T92A31G2	2	14	14	32	35
8.5	11.0	2-75	9T92A32	9T92A32G2	2	14	14	32	35
14.0	14.0	2-85	9T92A42	9T92A42G2	2	8	8	67	73
16.0	16.0	2-85	9T92A43	9T92A43G2	2	8	8	67	73
30.0	33.0	2-95	9T92A67	9T92A67G4	-----	9	36B	140	202
35.0	35.0	2-95	9T92A68	9T92A68G4	-----	9	36B	145	218
60.0	66.0	4-95	9T92A69	9T92A69G4	-----	11	36D	265	335
70.0	70.0	4-95	9T92A70	9T92A70G4	-----	11	36D	278	340
90.0	99.0	6-95	9T92A71	9T92A71G4	-----	11	36E	390	460
105.0	105.0	6-95	9T92A72	9T92A72G4	-----	11	36E	413	475

- When over voltage connection is used, rated current should not be exceeded.
- When using extended tap connections, operation is for 60-hertz only.
- Output at overvoltage connection is 0-110% of input voltage.
- When operated with this input voltage, rated current must be reduced in accordance with Curve 1, page 2, when output voltage exceeds 140% of input voltage.
- 60 hertz only.
- For line-voltage connection only, no overvoltage connection provided.
- Shipped connected for 0-100% of input voltage.
- Shipped connected for 0-117% of input voltage.
- Component listed by UL, uncased units only. Add suffix AIM to model No.
- Order 1 terminal enclosure kit per core to convert this model to enclosed terminals.

Volt-Pac Variable Autotransformer

MANUAL, THREE-PHASE

Line Voltage (0-100%) or Over Voltage (0-117%) Connection ¹ Rated Amperes	Line Voltage (0-100%) Connection Only Max. Amperes (For Constant Impedance Loads)	No. of Cores & Frame Size	UNCASED MODELS	CASED MODELS	Foot Notes	OUTLINE DIMENSIONS		Approx. Net Wt. Lb.	
			Model No.	Model No.		Uncased Fig. No. See pages 13,14,15	Cased Fig. No. See pages 13-17	Uncased	Cased

**240 VOLT LINE TO LINE INPUT: OUTPUT 0-240VOLT (LINE VOLTAGE CONNECTION)
0-280 VOLT (OVERVOLTAGE CONNECTION) (WYE CONNECTION)**

6.5 10.0	8.0 11.5	3-50 3-60	9T92A19 9T92A21	9T92A19G2 9T92A21G2	3, 5, 10 2, 10	17 13	17 13	25 33	27 35
12.0 15.0 18.0 30.0	14.5 19.0 21.7 34.0	3-60 3-75 3-75 3-85	9T92A22 9T92A33 9T92A34 9T92A44	9T92A22G2 9T92A33G2 9T92A34G2 9T92A44G2	5, 6, 10 2, 10 2, 10 2, 10	13 14 14 10	13 14 14 10	33 48 48 100	35 52 52 110
34.0 50.0 60.0 68.0	37.0 55.0 60.0 74.0	3-85 3-95 3-95 6-85	9T92A45 9T92A74 9T92A75 9T92A48	9T92A45G2 9T92A74G4 9T92A75G4 9T92A48G4	2, 10 2 2 2	10 11 11 12	10 36C 36C 12	100 210 210 190	110 265 265 210
100.0 120.0	110.0 120.0	6-95 6-95	9T92A78 9T92A79	9T92A78G4 9T92A79G4	----- -----	11 11	36E 36E	390 413	460 475

**480 VOLT LINE TO LINE INPUT: OUTPUT 0-480 VOLT (LINE VOLTAGE CONNECTION)
0-560 VOLT (OVERVOLTAGE CONNECTION) (WYE CONNECTION) OR 240-VOLT INPUT: OUTPUT 0-560 VOLTS (Note 4)**

4.0 5.0 7.0 8.5	5.0 6.8 10.1 11.0	3-60 3-60 3-75 3-75	9T92A25 9T92A26 9T92A35 9T92A36	9T92A25G2 9T92A26G2 9T92A35G2 9T92A36G2	2, 10 5, 6, 10 2, 10 2, 10	13 13 14 14	13 13 14 14	33 33 48 48	35 35 52 52
14.0 16.0 30.0	14.0 16.0 33.0	3-85 3-85 3-95	9T92A46 9T92A47 9T92A76	9T92A46G2 9T92A47G2 9T92A76G4	2, 10 2, 10 2	10 10 11	10 10 36C	100 100 210	110 110 265
35.0 60.0 70.0	35.0 66.0 70.0	3-95 6-95 6-95	9T92A77 9T92A80 9T92A81	9T92A77G4 9T92A80G4 9T92A81G4	----- 2 -----	11 11 11	36C 36E 36E	211 390 413	265 460 475

**240 VOLT LINE TO LINE INPUT: OUTPUT 0-240 VOLTS (LINE VOLTAGE CONNECTION)
0-280 VOLT (OVERVOLTAGE CONNECTION) (OPEN DELTA CONNECTION)**

4.0 5.0 7.0 8.5	5.0 6.8 10.1 11.0	2-60 2-60 2-75 2-75	9T92A17 9T92A18 9T92A31 9T92A32	9T92A17G2 9T92A18G2 9T92A31G2 9T92A32G2	2, 10 6, 10 2, 10 2, 10	13 13 14 14	13 13 14 14	22 22 32 32	23 1/2 23 1/2 35 35
14.0 16.0 30.0 35.0	14.0 16.0 33.0 35.0	2-85 2-85 2-95 2-95	9T92A42 9T92A43 9T92A67 9T92A68	9T92A42G2 9T92A43G2 9T92A67G4 9T92A68G4	2, 10 2, 10 ----- -----	8 8 9 9	8 8 36B 36B	67 67 140 145	73 73 202 210
60.0 70.0 90.0 105.0	66.0 70.0 99.0 105.0	4-95 4-95 6-95 6-95	9T92A69 9T92A70 9T92A71 9T92A72	9T92A69G4 9T92A70G4 9T92A71G4 9T92A72G4	----- ----- ----- -----	11 11 11 11	36D 36D 36E 36E	265 278 390 413	335 340 460 475

1. When over voltage connection is used, rated current should not be exceeded.
2. When using extended tap connections, operation is for 60-hertz only.
3. Output at overvoltage connection is 0-110% of input voltage.
4. When operated with this input voltage, rated current must be reduced in accordance with Curve 1, page 2, when output voltage exceeds 140% of input voltage.
5. 60 hertz only.
6. For line-voltage connection only, no overvoltage connection provided.
7. Shipped connected for 0-100% of input voltage.
8. Shipped connected for 0-117% of input voltage.
9. Component listed by UL, uncased units only. Add suffix AIM to model No.
10. Order 1 terminal enclosure kit per core to convert this model to enclosed terminals.

Terminal Enclosure Kits see page 9

UL LISTING

All manual, single-phase, uncased, 30, 40, 50 and 60 frame sizes have component listing as noted.

Volt-Pac Variable Autotransformer

MOTOR-OPERATED, SINGLE-PHASE

Weschler Instruments motor-operated Volt-Pac units differ from manual types primarily in the means used to rotate the shaft to vary output voltage. A self-synchronous motor is used to position the output voltage selector. The motor is reversible by means of a SPDT switch (not supplied) and operates on 120-volt, 50/60 hertz circuits.

Typical methods for controlling Weschler Instruments motor-operated Volt-Pacs include:

(1) Manual raise-lower switch—can consist of either momentary-contact push-button or lever-type toggle switch.

(2) Relays and contactors—control the raise-lower power to the motor as a result of low-level signals from external circuitry. Example: photoelectric cells or thermostat signals can provide the input.

(3) Process control instrumentation—for closed-loop, precise control, more sophisticated circuitry can be used to provide the raise-lower switching for the motor.

If you require motor operating times other than the 26 seconds, you drop the -G51 or -G54 suffix in the Volt-Pac model listing and replace it with a suffix from the table on page 9.

Line Voltage (0-100%) or Over Voltage (0-117%) Connection ¹ Rated Amperes	Line Voltage (0-100%) Connection Only Max. Amperes (For Constant Impedance Loads)	No. of Cores & Frame Size	UNCASED MODELS	CASED MODELS	Foot Notes	OUTLINE DEMENSIONS		Approx. Net Wt. Lb.	
			Model No. (See Pg. 9 for Motor Operating Times)	Model No. (See Pg. 9 for Motor Operating Times)		Uncased See Fig. No. Pages 15-16	Cased See Fig. No. Pages 15-17	Uncased	Cased

120 VOLT INPUT: OUTPUT 0-120 VOLT (LINE VOLTAGE CONNECTION) 0-140 VOLT (OVERVOLTAGE CONNECTION)

6.5 10.0	8.0 11.5	1-50 1-60	9T92C7G51 9T92C9G51	9T92C7G54 9T92C9G54	2, 3, 10 10	21 22	21 22	13 14	14 16
12.0 15.0 18.0 30.0	14.5 19.0 21.7 34.0	1-60 1-75 1-75 1-85	9T92C10G51 9T92C27G51 9T92C28G51 9T92D37G51	9T92C10G54 9T92C27G54 9T92C28G54 9T92D37G54	5, 6, 10 2, 10 2, 10 2	22 23 23 24	22 33 33 36F	14 21 21 49	16 30 30 87
34.0 50.0 60.0 68.0	37.0 55.0 60.0 74.0	1-85 1-95 1-95 2-85	9T92D38G51 9T92D49G51 9T92D50G51 9T92D41G51	9T92D38G54 9T92D49G54 9T92D50G54 9T92D41G54	2 ----- ----- 2	24 25 25 26	36F 36K 36K 36G	49 87 87 85	87 115 127 143
100.0 120.0 150.0 200.0 250.0 300.0 360.0	110.0 120.0 165.0 220.0 275.0 330.0 360.0	2-95 2-95 3-95 4-95 5-95 6-95 6-95	9T92D53G51 9T92D54G51 9T92D55G51 9T92D56G51 9T92D57G51 9T92D58G51 9T92D59G51	9T92D53G54 9T92D54G54 9T92D55G54 9T92D56G54 9T92D57G54 9T92D58G54 9T92D59G54	----- ----- ----- ----- ----- ----- -----	27 27 28 28 28 28 28	36L 36L 36L 36M 36M 36M 36M	150 150 240 300 360 420 420	225 225 315 405 465 525 525

240 VOLT INPUT: OUTPUT 0-240 VOLT (LINE VOLTAGE CONNECTION) 0-280 VOLT (OVERVOLTAGE CONNECTION) OR 120-VOLT INPUT: OUTPUT 0-280 VOLT (Note 4)

4.0 5.0 7.0 8.5	5.0 6.8 10.1 11.0	1-60 1-60 1-75 1-75	9T92C13G51 9T92C14G51 9T92C29G51 9T92C30G51	9T92C13G54 9T92C14G54 9T92C29G54 9T92C30G54	10 6, 10 10 2, 10	22 22 23 23	22 22 23 23	14 14 21 21	16 16 30 30
12.0 14.0 16.0 30.0	14.5 14.0 16.0 33.0	2-60 1-85 1-85 1-95	9T92C23G41 9T92D39G51 9T92D40G51 9T92D51G51	9T92C23G54 9T92D39G54 9T92D40G54 9T92D51G54	5, 6, 10 2 2 -----	29 24 24 25	29 36F 36F 36K	28 49 49 87	29 87 87 115
35.0 60.0 90.0 120.0 150.0 180.0 210.0	35.0 66.0 99.0 132.0 165.0 198.0 210.0	1-95 2-95 3-95 4-95 5-95 6-95 6-95	9T92D52G51 9T92D60G51 9T92D62G51 9T92D63G51 9T92D64G51 9T92D65G51 9T92D66G51	9T92D52G54 9T92D60G54 9T92D62G54 9T92D63G54 9T92D64G54 9T92D65G54 9T92D66G54	----- ----- ----- ----- ----- ----- -----	25 27 28 28 28 28 28	36K 36L 36L 36M 36M 36M 36M	87 150 240 300 360 420 420	115 225 315 405 465 525 525

480 VOLT INPUT: OUTPUT 0-480 VOLT (LINE VOLTAGE CONNECTION) 0-560 VOLT (OVERVOLTAGE CONNECTION) OR 240-VOLT INPUT: OUTPUT 0-560 VOLT (Note 4)

4.0 5.0 7.0 8.5	5.0 6.8 10.1 11.0	2-60 2-60 2-75 2-75	9T92C17G51 9T92C18G51 9T92C31G51 9T92C32G51	9T92C17G54 9T92C18G54 9T92C31G54 9T92C32G54	10 6, 10 2, 10 2, 10	29 29 30 30	29 29 30 30	28 28 38 38	29 29 50 50
14.0 16.0 30.0 35.0 60.0	14.0 16.0 33.0 35.0 66.0	2-85 2-85 2-95 2-95 4-95	9T92D42G51 9T92D43G51 9T92D67G51 9T92D68G51 9T92D69G51	9T92D42G54 9T92D43G54 9T92D67G54 9T92D68G54 9T92D69G54	2 2 ----- ----- -----	26 26 27 27 28	36G 36G 36L 36L 36M	85 85 150 150 300	132 132 225 225 405
70.0 90.0 105.0 120.0	70.0 99.0 105.0 132.0	4-95 6-95 6-95 8-95	9T92D70G51 9T92D71G51 9T92D72G51 9T92D73G51	9T92D70G54 9T92D71G54 9T92D72G54 9T92D73G54	----- ----- ----- -----	28 28 28 28	36M 36M 36M 36N	300 420 420 540	405 525 525 675

1. When over voltage connection is used, rated current should not be exceeded.

2. When using extended tap connections, operation is for 60-hertz only.

3. Output at overvoltage connection is 0-110% of input voltage.

4. When operated with this input voltage, rated current must be reduced in accordance with Curve 1, page 2, when output voltage exceeds 140% of input voltage.

5. 60 hertz only.

6. For line-voltage connection only, no overvoltage connection provided.

7. Shipped connected for 0-100% of input voltage.

8. Shipped connected for 0-117% of input voltage.

9. Component listed by UL, uncased units only. Add suffix AIM to model No.

10. Order 1 terminal enclosure kit per core to convert this model to enclosed terminals.



Volt-Pac Variable Autotransformer

MOTOR-OPERATED, THREE-PHASE

MOTOR OPERATING TIME

Motor operating time refers to the number of seconds for the motor to traverse its full range in one direction. In the motor-operated listing, most Volt-Pac model numbers are standard 26-second motor operating time.

If you require motor operating times other than the 26 seconds, you drop the -G51 or -G54 suffix in the Volt-Pac model listing and replace it with a suffix from the table on page 9.

Line Voltage (0-100%) or Over Voltage (0-117%) ¹ Rated Amperes	Line Voltage (0-100%) Connection Only Max. Amperes (For Constant Impedance Loads)	No. of Cores & Frame Size	UNCASED MODELS	CASED MODELS	Foot Notes	OUTLINE DEMENSIONS		Approx. Net Wt. Lb.	
			Model No. (See Pg. 9 for Motor Operating Times)	Model No. (See Pg. 9 for Motor Operating Times)		Uncased See Fig. No. Pages 15-17	Cased See Fig. No. Pages 15-17	Uncased	Cased

240 VOLT INPUT: OUTPUT 0-240 VOLT (LINE VOLTAGE CONNECTION) 0-280VOLT (OVERVOLTAGE CONNECTION) (WYE CONNECTION)

6.5	8.0	3-50	9T92C19G51	9T92C19G54	3, 5, 10	35	35	30	32
10.0	11.5	3-60	9T92C21G51	9T92C21G54	2, 10	29	29	38	41
12.0	14.5	3-60	9T92C22G51	9T92C22G54	5, 6, 10	29	29	38	41
15.0	19.0	3-75	9T92C33G51	9T92C33G54	2, 10	30	30	55	70
18.0	21.7	3-75	9T92C34G51	9T92C34G54	2, 10	30	30	55	70
30.0	34.0	3-85	9T92D44G51	9T92D44G54	2	31	36H	115	172
34.0	37.0	3-85	9T92D45G51	9T92D45G54	2	31	36H	119	172
50.0	55.0	3-95	9T92D74G51	9T92D74G54	2	28	36L	240	315
60.0	60.0	3-95	9T92D75G51	9T92D75G54	2	28	36L	240	315
68.0	74.0	6-85	9T92D48G51	9T92D48G54	2	34	36J	225	300
100.0	110.0	6-95	9T92D78G51	9T92D78G54	2	28	36M	420	525
120.0	120.0	6-95	9T92D79G51	9T92D79G54	-----	28	36M	420	525
150.0	165.0	9-95	9T92D82G51	9T92D82G54	2	28	36N	600	735
180.0	180.0	9-95	9T92D83G51	9T92D83G54	-----	28	36N	600	735
200.0	200.0	12-95	9T92D400G61	9T92D400G64	7	-----	36P	810	985
200.0	200.0	12-95	9T92D400G71	9T92D400G74	8	-----	36P	810	985
250.0	250.0	15-95	9T92D401G61	9T92D401G64	7	-----	36P	1000	1180
250.0	250.0	15-95	9T92D401G71	9T92D401G74	8	-----	36P	1000	1180
300.0	300.0	18-95	9T92D402G61	9T92D402G64	7	-----	36P	1200	1400
300.0	300.0	18-95	9T92D402G71	9T92D402G74	8	-----	36P	1200	1400

480 VOLT INPUT: OUTPUT 0-480 VOLT (LINE VOLTAGE CONNECTION) 0-560 VOLT (OVERVOLTAGE CONNECTION) (WYE CONNECTION) OR 240 VOLT INPUT: OUTPUT 0-560 VOLT (Note 4)

4.0	5.0	3-60	9T92C25G51	9T92C25G54	2, 10	29	29	38	41
5.0	6.8	3-60	9T92C26G51	9T92C26G54	5, 6, 10	29	29	38	41
7.0	10.1	3-75	9T92C35G51	9T92C35G54	2, 10	30	30	55	78
8.5	11.0	3-75	9T92C36G51	9T92C36G54	2, 10	30	30	55	78
14.0	14.0	3-85	9T92D46G51	9T92D46G54	2	31	36H	115	172
16.0	16.0	3-85	9T92D47G51	9T92D47G54	2	31	36H	115	172
30.0	33.0	3-95	9T92D76G51	9T92D76G54	2	28	36L	240	315
35.0	35.0	3-95	9T92D77G51	9T92D77G54	2	28	36L	240	315
60.0	66.0	6-95	9T92D80G51	9T92D80G54	2	28	36M	420	525
70.0	70.0	6-95	9T92D81G51	9T92D81G54	2	28	36M	420	525
90.0	99.0	9-95	9T92D84G51	9T92D84G54	2	28	36N	600	735
105.0	105.0	9-95	9T92D85G51	9T92D85G54	2	28	36N	600	735
120.0	120.0	12-95	9T92C410G61	9T92C410G64	7	-----	36P	810	985
120.0	120.0	12-95	9T92C410G71	9T92C410G74	8	-----	36P	810	985
150.0	150.0	15-95	9T92C411G61	9T92C411G64	7	-----	36P	1000	1180
150.0	150.0	15-95	9T92C411G71	9T92C411G74	8	-----	36P	1000	1180
180.0	180.0	18-95	9T92C412G61	9T92C412G64	7	-----	36P	1200	1400
180.0	180.0	18-95	9T92C412G71	9T92C412G74	8	-----	36P	1200	1400
210.0	210.0	21-95	9T92C413G61	9T92C413G64	7	-----	36P	1400	1600
210.0	210.0	21-95	9T92C413G71	9T92C413G74	8	-----	36P	1400	1600
240.0	240.0	24-95	9T92C414G61	9T92C414G64	7	-----	36P	1500	1700
240.0	240.0	24-95	9T92C414G71	9T92C414G74	8	-----	36P	1500	1700

240 VOLT INPUT: OUTPUT 0-240 VOLT (LINE VOLTAGE CONNECTION) 0-280-VOLT (OVERVOLTAGE CONNECTION) (OPEN DELTA CONNECTION)

4.0	5.0	2-60	9T92C17G51	9T92C17G54	10	29	29	28	28 1/2
5.0	6.8	2-60	9T92C18G51	9T92C18G54	6, 10	29	29	28	28 1/2
7.0	10.1	2-75	9T92C31G51	9T92C31G54	2, 10	30	30	38	50
8.5	11.0	2-75	9T92C32G51	9T92C32G54	2, 10	30	30	38	50
14.0	14.0	2-85	9T92D42G51	9T92D42G54	2	26	36G	85	132
16.0	16.0	2-85	9T92D43G51	9T92D43G54	2	26	36G	85	132
30.0	33.0	2-95	9T92D67G51	9T92D67G54	-----	27	36L	150	225
35.0	35.0	2-95	9T92D68G51	9T92D68G54	-----	27	36L	150	225
60.0	66.0	4-95	9T92D69G51	9T92D69G54	-----	28	36M	300	405
70.0	70.0	4-95	9T92D70G51	9T92D70G54	-----	28	36M	300	405
90.0	99.0	6-95	9T92D71G51	9T92D71G54	-----	28	36M	420	525
105.0	105.0	6-95	9T92D72G51	9T92D72G54	-----	28	36M	420	525
120.0	132.0	8-95	9T92D73G51	9T92D73G54	-----	28	36N	540	675

- When over voltage connection is used, rated current should not be exceeded.
- When using extended tap connections, operation is for 60-hertz only.
- Output at overvoltage connection is 0-110% of input voltage.
- When operated with this input voltage, rated current must be reduced in accordance with Curve 1, page 2, when output voltage exceeds 140% of input voltage.
- 60 hertz only.
- For line-voltage connection only, no overvoltage connection provided.
- Shipped connected for 0-100% of input voltage.
- Shipped connected for 0-117% of input voltage.
- Component listed by UL, uncased units only. Add suffix AIM to model No.
- Order 1 terminal enclosure kit per core to convert this model to enclosed terminals.

Volt-Pac Variable Autotransformer

TERMINAL ARRANGEMENTS, CONNECTIONS AND WIRING

TERMINAL ARRANGEMENTS

Weschler Instruments Volt-Pac transformer terminal boards are constructed and imprinted to facilitate connection to line and load. Most terminal boards are designed for ring or spade terminals and 1/4" female quick-connect terminals. The table at right illustrates typical terminal connections for many common ratings. Specific terminal details are shown with the outline diagrams on pages 13-17.

WIRING DIAGRAMS

Below are wiring diagrams for two basic types of Volt-Pac variable transformer connections.

Line-voltage Connection

NOTES FOR CONNECTIONS

NOTE 1.

Connection diagrams for single-phase ratings using more than two cores, and for three-phase (wye) ratings using more than three cores, may be obtained by contacting your Weschler Instrument sales representative.

NOTE 2.

Ratings which have no tap connection utilize a three-terminal arrangement **NOT** shown in the adjacent connection diagrams.

NOTE 3.

Three-phase unit is shipped with knob on the end of unit opposite the base and with jumpers connecting terminals 1-1-1, (clockwise rotation will raise voltage). If knob is moved to the other end, remove jumpers from 1-1-1, and connect terminals 4-4-4 (this will maintain clockwise rotation to raise voltage).

OPTIONS AND FEATURES MAY VARY BETWEEN MODELS, CONTACT FACTORY FOR SPECIFICS. IN A CONSTANT EFFORT TO IMPROVE OUR PRODUCTS, SPECIFICATIONS MAY CHANGE FROM THOSE PUBLISHED.

CONNECTIONS FOR COMMONLY USED RATINGS

Terminal Diagrams	Connection	Terminals Used	
		Surface Mounting (Clockwise Rotation) Knob on End Opposite Base	Back-of-panel Mounting (Clockwise Rotation) Knob on Base End
SINGLE-PHASE, SINGLE-CORE, 120-VOLT INPUT, 0-120/132-VOLT OUTPUT, 30 FRAME			
	Input 120V		1-2
	Output 0-120V		1-3
	Input 120V		1-4
	Output 0-132V		1-3
SINGLE-PHASE, SINGLE-CORE, 120-VOLT INPUT, 0-120/140-VOLT OUTPUT, (EXCEPT 30 FRAME)			
	Input 120V	1-4	4-1
	Output 0-120V	1-3	4-3
	Input 120V	1-2	4-5
	Output 0-140V	1-3	4-3
SINGLE-PHASE, SINGLE-CORE, 120-VOLT OR 240-VOLT INPUT, 0-240/280-VOLT OUTPUT			
	Input 120V	1-6	4-7
	Output 0-280V	1-3	4-3
	Input 240V	1-4	4-1
	Output 0-240V	1-3	4-3
	Input 240V	1-2	4-5
	Output 0-280V	1-3	4-3
SINGLE-PHASE, TWO-CORE, 240- OR 480-VOLT INPUT, 0-480/560-VOLT OUTPUT			
	Input 240V	6-6	7-7
	Output 0-560V	3-3	3-3
	Jumper	1-1	4-4
	Input 480V	4-4	1-1
	Output 0-480V	3-3	3-3
	Jumper	1-1	4-4
	Input 480V	2-2	5-5
	Output 0-560V	3-3	3-3
	Jumper	1-1	4-4
	THREE-PHASE (WYE), THREE-CORE, 240-VOLT INPUT, 0-240/280-VOLT OUTPUT		
	Input 240V	4-4-4	1-1-1
	Output 0-240V	3-3-3	3-3-3
	Jumper	1-1-1	4-4-4
	Input 240V	2-2-2	5-5-5
	Output 0-280V	3-3-3	3-3-3
	Jumper	1-1-1	4-4-4
THREE-PHASE (WYE), THREE-CORE, 240- OR 480-VOLT INPUT, 0-480/560-VOLT OUTPUT			
	Input 240V	6-6-6	7-7-7
	Output 0-560V	3-3-3	3-3-3
	Jumper	1-1-1	4-4-4
	Input 480V	4-4-4	1-1-1
	Output 0-480V	3-3-3	3-3-3
	Jumper	1-1-1	4-4-4
	Input 480V	2-2-2	5-5-5
	Output 0-560V	3-3-3	3-3-3
	Jumper	1-1-1	4-4-4
	THREE-PHASE (OPEN DELTA), TWO-CORE, 120- OR 240-VOLT INPUT, 0-120/140-VOLT OUTPUT AND 240-VOLT INPUT, 0-240/280 VOLT OUTPUT		
	Input 120V	4-1-4	1-4-1
	Output 0-120V	3-1-3	3-4-3
	Jumper	1-1	4-4
	Input 120V	2-1-2	5-4-5
	Output 0-140V	3-1-3	3-4-3
	Jumper	1-1	4-4
	Input 240V	4-1-4	1-4-1
	Output 0-240V	3-1-3	3-4-3
	Jumper	1-1	4-4
	Input 240V	4-1-4	1-4-1
	Output 0-280V	3-1-3	3-4-3
	Jumper	1-1	4-4

Volt-Pac Variable Autotransformer

TERMINAL ENCLOSURE KIT

TERMINAL ENCLOSURE KITS

When Volt-Pac models with enclosed terminals are required, modification kits can be purchased economically to convert exposed-terminal models to enclosed ones. A different terminal kit is available for each Volt-Pac frame size. The frame size and number of cores for each Volt-Pac unit is listed in the third column of the

tables on pages 4-7. Always order a quantity of kits corresponding to the number of cores. For example, when an enclosed version of Volt-Pac Model 9T92A41G2 is desired, order one (1) Volt-Pac Model No. 9T92A41G2 and two (2) kits, Model No. 9T18Y903G4. See dimensions below.

For Frame Size	Order Model Number	
30	no kits available	-----
50	9T18Y903	Kit only
60	9T18Y903G2	Kit only
75	9T18Y903G3	Kit only
85	9T18Y903G4	Kit only

DIMENSIONS - CASED MODELS with TERMINAL ENCLOSURE KIT

Note: Refer to pages 13-15 for detailed dimensions of cased models with exposed terminals. When proper Fig. No. from pages 13-15 has been located, the diagrams and table below will provide overall dimensions for cased units with enclosed terminals.

Fig. No. From Pgs. 13-15	Frame Size & No. of Cores	Dimensions in Inches	
		A	A ¹
3	50-1	-----	6 5/8
4	60-1	-----	6 5/8
5	75-1	-----	8
6	85-1	-----	12
8	85-2	12 3/8	-----
10	85-3	12 1/4	-----
12	85-6	11 7/8	-----
13	60-2	7 1/4	-----
13	60-3	7 1/4	-----
14	75-2	8 5/8	-----
14	75-3	8 5/8	-----
17	50-2	7 1/4	-----
17	50-3	7 1/4	-----

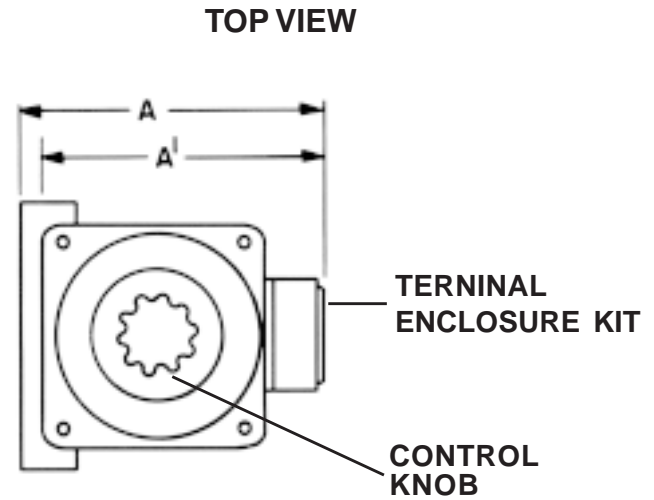

MOTOR OPERATING TIME

Motor operating time refers to the number of seconds for the motor to traverse its full range in one direction. In the motor operated listing, most Volt-Pac model numbers are for standard 26.2 second motor operating time. If you require motor operating time other than the 26.2, you must drop the G51 or G54 suffix in the Volt-Pac model listing and replace it with a suffix from the table below.

SUFFIX TABLE

Time of Operation (Sec.)		Add Suffix No.	
60 hertz	50 hertz	Uncased	Cased
For All 30, 40, 50, 60 and 75 Frame Sizes*			
4.4	5.3	G21	G24
13.1	15.7	G41	G44
26.2	31.4	G51	G54
54.6	65.6	G61	G64

Time of Operation (Sec.)		Add Suffix No.	
60 hertz	50 hertz	Uncased	Cased
For All 85 and 95 Frame Sizes			
3.7	4.4	G21	G24
8.7	10.4	G31	G34
18.2	21.8	G41	G44
26.2	31.4	G51	G54
54.6	65.5	G61	G64

Volt-Pac Automatic Voltage Regulator

Almost every aspect of our lives is affected when electric power becomes unstable. Dependence on quality power increases while power problems become more predominate. Generation capacity and the distribution system have not kept pace with increased demand for electricity. Competition forces equipment manufacturers to push component limits, making them more sensitive to voltage fluctuations. Many electrical loads now create voltage imbalances due to non sinusoidal current draw. Power company corrections for low voltage in one area result in high voltage in another. Poor power quality is a silent killer causing unexplained equipment glitches and premature failures, increasing downtime and cost. Surveys show voltage sags represent 87% of short term power disturbances. VoltPac Voltage Regulators solve voltage regulation problems by providing $\pm 1\%$ or better output voltage regulation over their broad input range. Proven techniques combined with high quality components provide highly reliable, 99% efficient units and high momentary overload capacity.

APPLICATIONS	
Broadcast:	Transmitters, Receivers, Studios, and Mobile production units
Industrial:	Large Motor, Plating Systems, Resistance Heating, Machine Tool, Magnetic Solenoids and Clutches, Welders, Distribution Equipment, Test Equipment Power Supplies
Marine:	Private and Commercial Shipboard and Shore Power Conditioning
Commercial:	Lighting, Elevator Controls, Chillers, UPS Nuisance Trip Prevention, High Rise Buildings
Medical:	X-Ray, MRI, CAT Scan Equipment
Electronic:	Radar, Computers, Telecommunications
FEATURES	
Excellent Output Voltage Accuracy $\pm 1\%$	Low Impedance Design
99% Efficiency Typical	High Overload Capacity
No Waveform Distortion or Harmonics	Low Maintenance
Not Sensitive To Load Power Factor	-20° to +40° C Ambient Operating Temperature Range
Fast Voltage Correction	Loss of Regulation Will Not Interrupt Power to Load
Adjustable Output Voltage	Insensitive to Frequency Changes
Manual Raise-Lower Switch	(47-63 HZ Operating Range)
Wide and Narrow Input	Voltage Range Selectable
Cabinet or Rack Mounted	Single and Three-Phase Models
Indoor Ventilated Drip-Proof Enclosure	1.5 to 500 KVA Rated Models Available
Output Voltmeter Included	Fused Control Circuit
	One-Year Warranty
OPTIONS	
Digital Control	Ammeters
Shifted Input Ranges	Input Voltage Range Alarm Contacts
Frequency Meter	



Catalog Number	Dimensions (Inches)		
	A	B	C
9T92C0101, 102,103,104,109,110	20 3/4	19 11/16	9 5/8
9T92D0105, 111	20 7/8	22	13 1/8
9T92D0106, 112	22 1/2	22	23 1/2
9T92C0114G03, 115GO3	24 1/16	17 7/8	15 3/4
9T92C0114, 115, 121	25 3/4	19 5/16	16 5/8
9T92D0116	21 3/4	18 1/4	20
9T92D0117, 125, 130, 155, 168	25	20 1/2	30
9T92C0122, 123, 127, 128	15 1/4	16 3/8	27
9T92D124, 129, 170	20	19	30
9T92D154, 176	31 1/2	22 1/2	65 1/2
9T92D167	33 1/2	20 1/2	72 1/2

Volt-Pac Automatic Voltage Regulator

	Narrow Input Voltage Range ⁴			Wide Input Voltage Range ⁴			Net Wt. (Lbs)	Catalog Number	
	Load		Correction Rate Volts/Sec	Load		Correction Rate Volts/Sec			
	Max Amp	KVA ¹		Max Amp	KVA ¹				
Single Phase	110 to 130 Volt Input			100 to 140 Volt Input					
	120	20.5	2.5	4.5	9.5	1.15	9.1	60	9T92C0101 ⁶
	Volts	31.5	3.8	4.5	14.0	1.70	9.1	80	9T92C0102 ⁶
		43.0	5.2	4.5	19.0	2.30	9.1	65	9T92C0103 ⁶
	115 to	86.5	10.4	4.5	38.0	4.60	9.1	125	9T92C0104 ⁶
	125 adj.	158.0	19.0	5.4	70.0	8.40	10.9	150	9T92D0105 ⁶
	output ²	220.0	26.5	5.4	100.0	12.00	10.9	170	9T92D0106 ⁶
	240	225 to 255 Volt Input ³			210 to 270 Volt Input ³				
	Volts	25.0	6.0	6.9	11.0	2.75	13.7	65	9T92C0109 ⁶
	230 to	57.5	13.8	6.9	27.0	6.5	13.7	125	9T92C0110 ⁶
	250 adj.	98.5	22.5	8.2	43.0	10.3	16.3	150	9T92D0111 ⁶
	output ²	185.0	44.5	8.2	85.0	20.5	16.3	170	9T92D0112 ⁶
	480	450 to 510 Volt Input			420 to 540 Volt Input				
	Volts	25.0	12.0	13.7	11.0	5.5	27.5	120	9T92C0114 ⁶
	460 to	57.0	27.5	13.7	27.0	13.0	27.5	140	9T02C0115 ⁶
	500 adj.	93.5	45.0	16.3	42.5	20.5	32.6	220	9T92D0116
output ²	185.0	89.0	16.3	85.0	41.0	32.6	350	9T92D0117	

	Narrow Input Voltage Range ⁴			Wide Input Voltage Range ⁴			Net Wt. (Lbs)	Catalog Number	
	Load		Correction Rate Volts/Sec	Load		Correction Rate Volts/Sec			
	Max Amp	KVA ¹		Max Amp	KVA ¹				
Three Phase	208/120	181 to 235 Volt Input ⁵							
	Volts	83.0	30.0	14.6	—	—	—	290	9T92D0170
		147.0	53.0	14.6	—	—	—	380	9T92D0155
	194 to	172.0	62.5	2.9	—	—	—	380	9T92D0168
	222 adj.	277.0	100.0	6.3	—	—	—	900	9T92D0176
	output ²	360.0	130.0	6.3	—	—	—	900	9T92D0154
		416.0	150.0	2.9	—	—	—	1100	9T92D0167
		624.0	225.0	2.9	—	—	—	1500	9T92D0163
	240	225 to 255 Volt Input ³			210 to 270 Volt Input ³				
	Volts	43.0	18.0	6.9	19.9	8.3	13.7	125	9T92D0121
		57.5	24.0	6.9	27.5	11.5	13.7	145	9T92D0122
	230 to	116.5	48.5	8.2	54.0	22.5	16.3	200	9T92D0123
	250 adj.	214.0	89.0	8.2	99.8	41.5	16.3	300	9T92D0124
	output ²	300.0	125.0	8.2	142.0	59.0	16.3	500	9T92D0125
	480/277	440 to 500 Volt Input			420 to 540 Volt Input				
	Volts	25.0	21.0	13.7	11.5	9.6	27.5	145	9T92D0127
	460 to	54.5	45.5	16.3	25.0	21.0	32.6	200	9T92D0128
	500 adj.	96.0	80.0	16.3	45.0	37.5	32.6	300	9T92D0129
	output ²	186.0	155.0	16.3	86.5	72.0	32.6	500	9T92D0130

1. Load KVA is based on output voltage at midpoint in the output range.
2. When output voltage is adjusted up or down from the midpoint, the rated input range will shift proportionately.
3. These models can be used for nominal 208 output (194-222 adjustable) and 181 to 236 volt input by changing connections as outlined in the connection diagrams included in shipping carton.
4. All models are connected for the narrow input voltage range when shipped.
5. Average input range, between wide and narrow.
6. Rack Mount units available, inquire with factory.

Volt-Pac Variable Autotransformer

DIMENSIONS

VoltPac Full Range Regulator / Controller

For Use With Any Synchronous Motor Driven Variable Autotransformer

The VoltPac 9T92PVC2 Full Range Regulator Controller is an intelligent microprocessor based unit. It regulates the output / load voltage of a motor operated variable voltage transformer to a user programmed value. These flexible units allow for operator definition of set point, dead-band, operating mode, frequency, and motor speed. Parameters are input through the keypad or serial 232, 422 or 485 ASCII communications port. The 5 digit 7 segment LED display provides local indication of output voltage and programmed settings. All parameters are also available through the serial port allowing for remote monitoring and control of the unit. Keypad lockout, and auto / manual control capability allow application flexibility. The unit may be configured for one, two or three control channels for use on single and polyphase systems with single line or independent phase control. The motor pulsing feature allows for fine adjustment of the output without overshoot.



Applications

Electric Motor testing
Plating rectifier systems
Compressor testing
Industrial processes
Appliance testing

Quality control labs
Voltage regulators
Lamp & ballast testing
Power Supplies
Telecom equipment testing

Features

Microprocessor controller
High visibility LED display
Non volatile memory
True RMS sensing
Autoranging to 600 volts

Regulation to +/- .5 volts
Up to 3 control channels
Std RS-232 com. Port
Adjustable deadband
Automatic regulation

Specifications

Input signal 0 – 600 ACV Auto ranging
Controller Power 120 VAC 50 or 60 HZ @ 5 watts max
Control outputs Solid state relay 3 A 120 volt
Accuracy +/- 0.4 VAC
Response time less than 0.1 sec
Communications 9600 Baud, 8 bits, No parity, 1 stop bit
Motor speed High or Low
Control modes single line, independent phase or bypass
Deadband 0 – 99.9 volts
Pulse adjust 0 – 99 volts

Options

RS – 422 Communications
RS – 485 Communications

Model Number Configuration

Model	Configuration	
	Channels	Communications
9T92PVC2-	1	A RS 232
	2	B RS 422
	3	C RS 485
9T92PVC2-		

Mounting Schematic

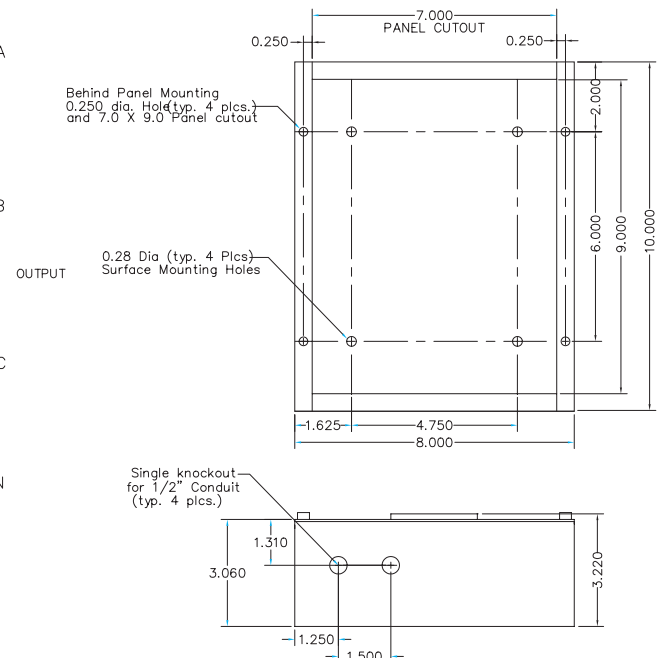
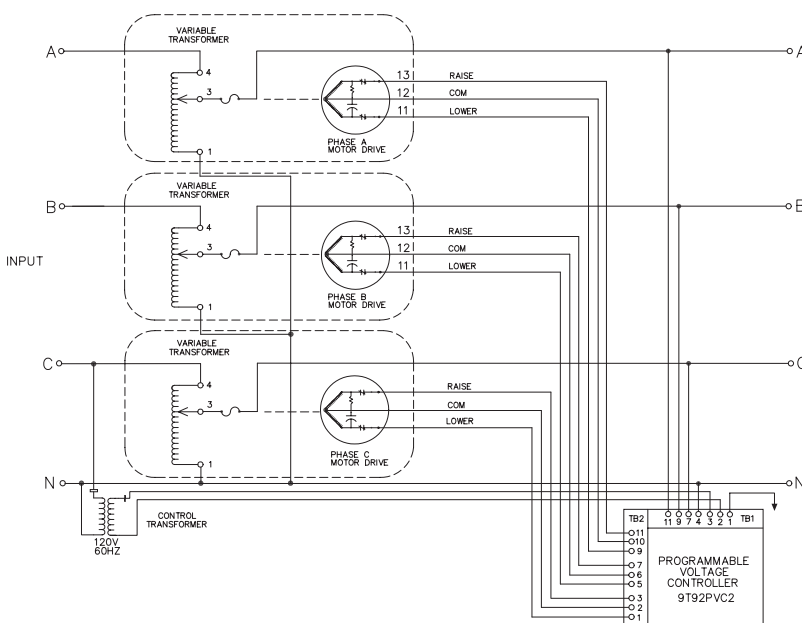

Volt-Pac Variable Autotransformer

DIMENSIONS

DIMENSIONS for Manual, Single and Three-Phase

Fig. 1 Frame 30 - 1 core

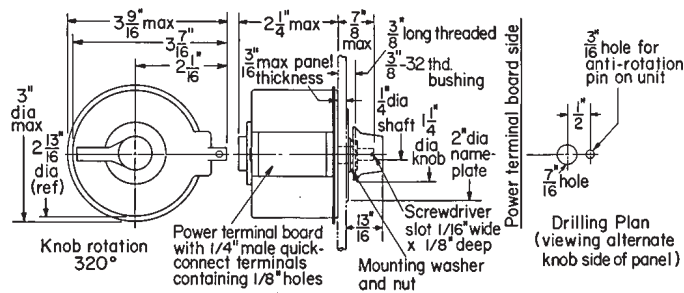

Fig. 5 Frame 75 - 1 core

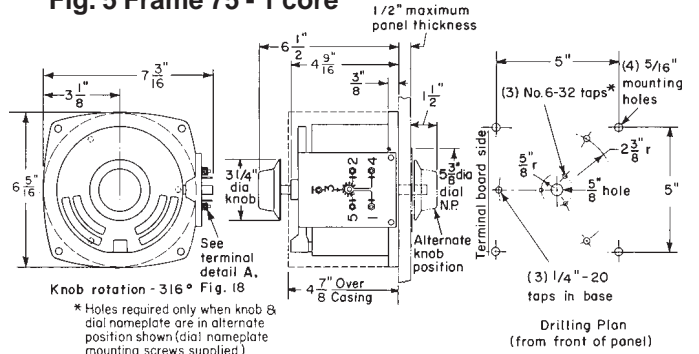

Fig. 2 Frame 40 - 1 core

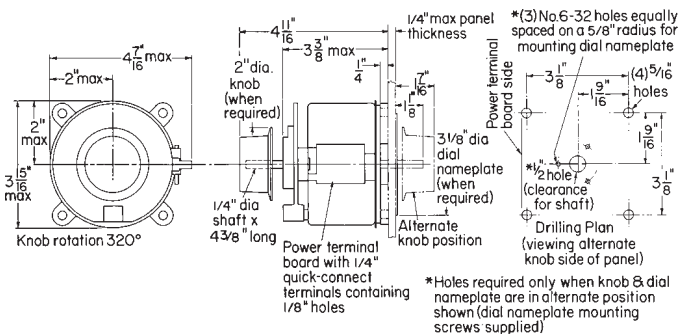

Fig. 6 Frame 85 - 1 core

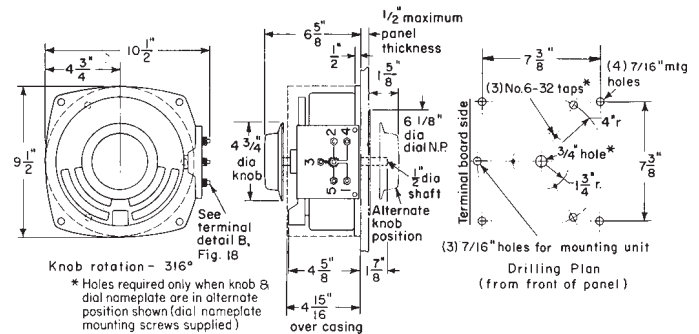

Fig. 3 Frame 50 - 1 core

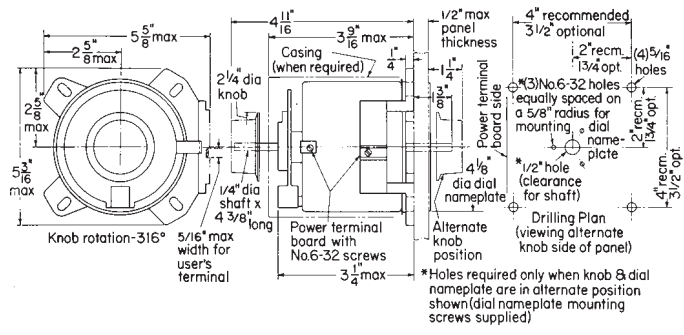

Fig. 7 Frame 95 - 1 core

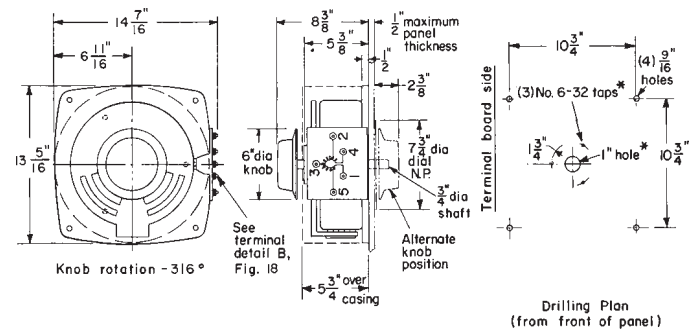

Fig. 4 Frame 60 - 1 core

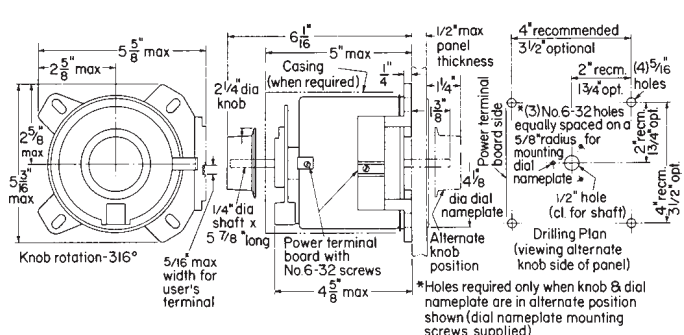
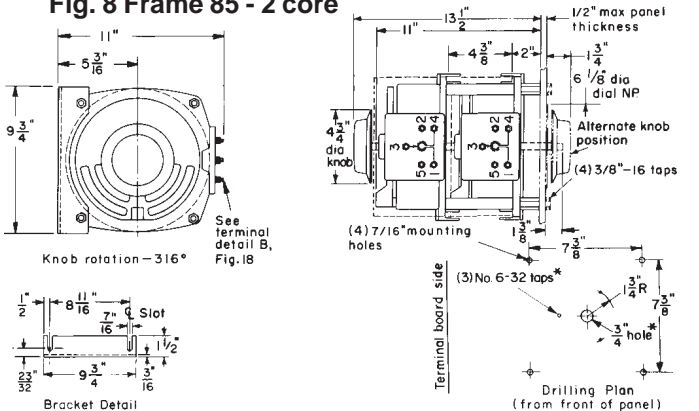

Fig. 8 Frame 85 - 2 core



Volt-Pac Variable Autotransformer

DIMENSIONS for Manual, Single and Three-Phase (Continued)

Fig. 9 Frame 95 - 2 core

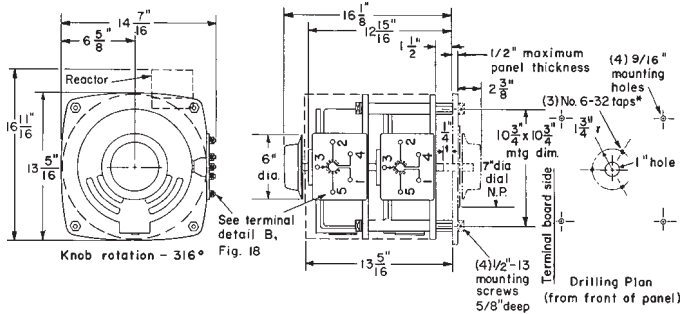
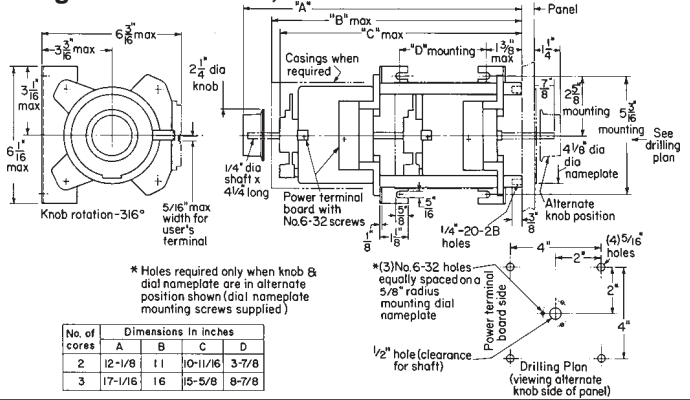

Fig. 13 Frame 60 - 2, 3 cores



No. of cores	Dimensions in inches			
	A	B	C	D
2	12-1/8	11	10-11/16	3-7/8
3	17-1/16	16	15-5/8	8-7/8

Fig. 10 Frame 85 - 3 core

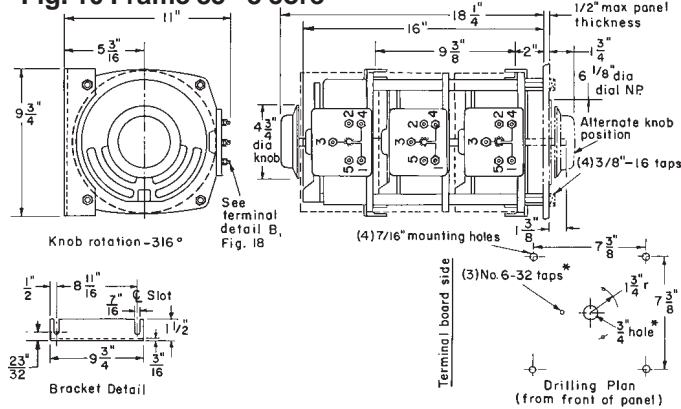

Fig. 14 Frame 75 - 2, 3 cores

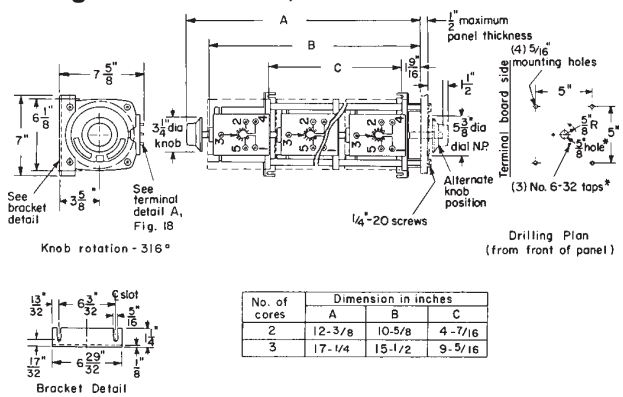
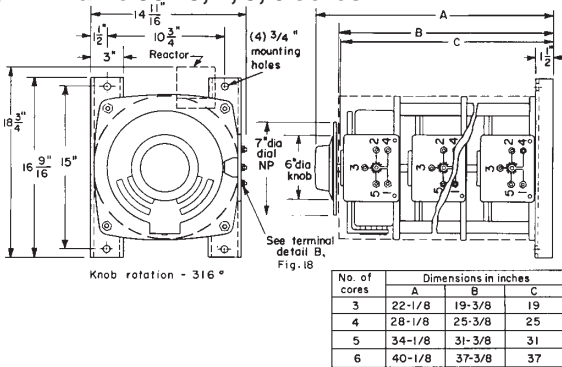

Fig. 11 Frame 95 - 3, 4, 5, 6 cores



No. of cores	Dimensions in inches		
	A	B	C
3	22-1/8	19-3/8	19
4	28-1/8	25-3/8	25
5	34-1/8	31-3/8	31
6	40-1/8	37-3/8	37

Fig. 15 Frame 30 - 2, 3 cores

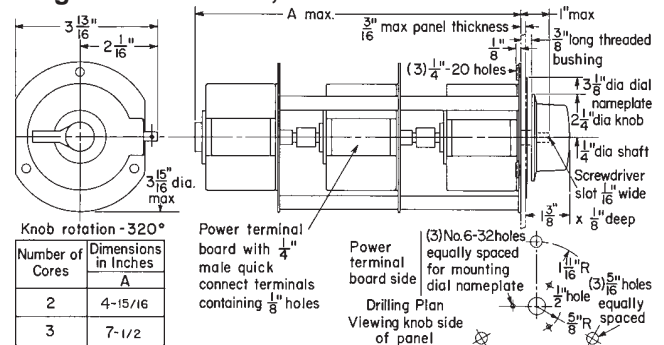

Fig. 12 Frame 85 - 6 core

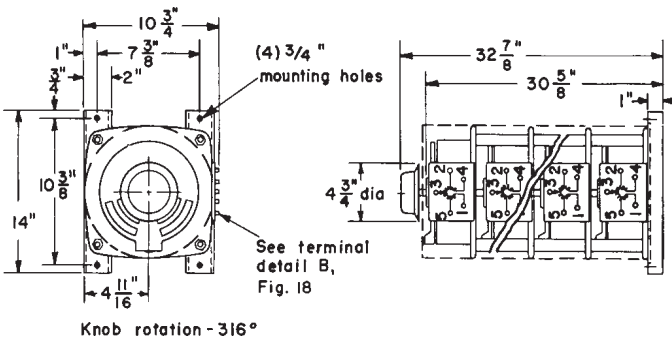
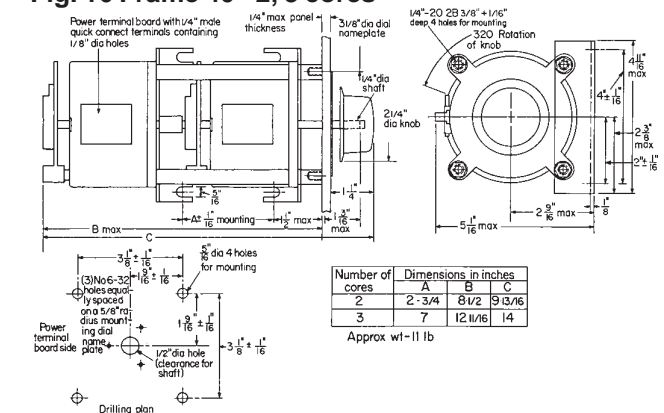

Fig. 16 Frame 40 - 2, 3 cores



Number of cores	Dimensions in inches		
	A	B	C
2	2-3/4	8 1/2	9 3/16
3	7	12 11/16	14

Approx wt=11 lb

Volt-Pac Variable Autotransformer

DIMENSIONS

MOTOR OPERATED, SINGLE AND THREE-PHASE (CONTINUED)

Fig. 31 Frame 85 - 3 cores

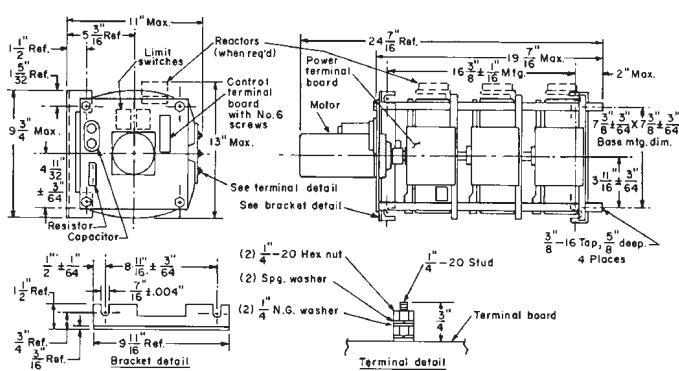

Fig. 34 Frame 85 - 6 cores

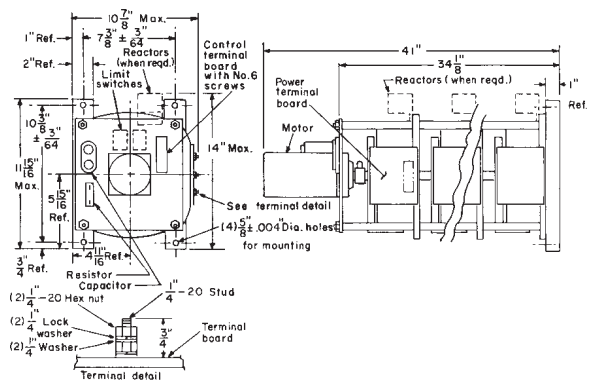

Fig. 32 Frame 30 - 2, 3 cores

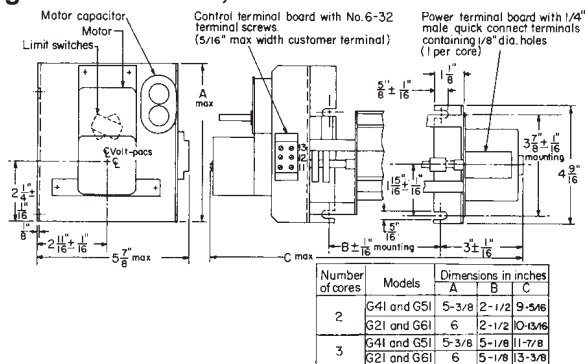

Fig. 35 Frame 50 - 2, 3 cores

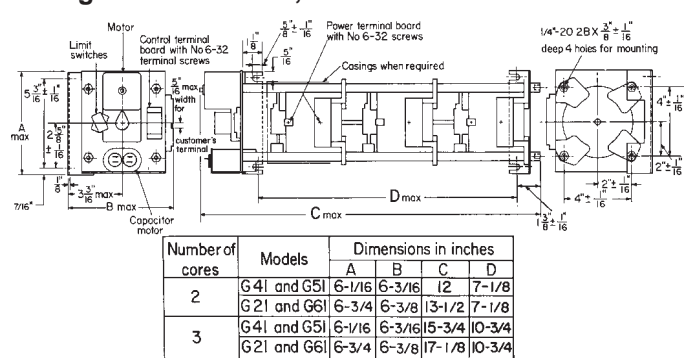

Fig. 33 Frame 40 - 2, 3, cores

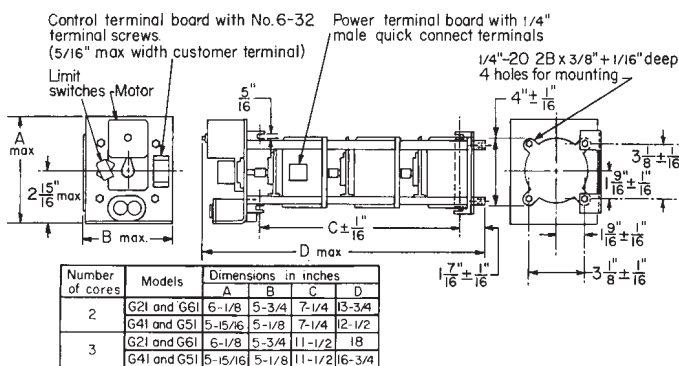

Fig. 36 Cased unit dimensions

Dimension Reference	Dimensions in inches		
	Width	Depth	Height
36A	16.00	17.00	8.50
36B	21.00	17.50	17.25
36C	21.00	17.50	23.00
36D	21.00	17.50	32.00
36E	21.00	17.50	44.00
36F	16.00	17.50	23.00
36G	16.00	17.50	30.50
36H	16.00	17.50	35.50
36J	16.00	17.50	48.50
36K	15.00	17.00	23.00
36L	21.00	17.50	34.00
36M	21.00	17.50	52.00
36N	21.00	17.50	70.00
36P	52.00	20.00	52.00