



CP11

Dual Slot 6U CompactPCI® SBC with Dual Core 32- or 64-bit Processor

Features

- Intel® Core™2 Duo processor, 1.5 GHz and 2.16 GHz
- Intel® Core™ Duo processor 1.66 GHz and 2.0 GHz
- Intel Celeron® M processor ULV 423, 1.06 GHz
- PICMG 2.1 (Hot Swap) compliant
- Ultra compact, two slots
- System and non-system functionality
- Up to 4 GB DDR2 SDRAM (200 MHz) with ECC
- Flash drive or local UDMA100 2.5" hard disk
- 2x SATA, RAID 0/1 capable
- Front/rear VGA up to 1280 x 1024, rear DVI-I up to 1280 x 1024, 32 MB RAM
- Two Gigabit Ethernet ports 10/100/1000 BaseT front or rear optional
- PICMG 2.16 compliant
- One front Fast Ethernet port
- Two PMC extension slots, one 64-bit/133 MHz and one 32-bit/33 MHz
- One XMC interface on request
- 2 x serial I/O with FIFOs RS-232/422/485 interface
- 4 x USB 2.0 ports, two front and two on rear
- Audio codec
- Watchdog, temperature sensors
- Optional -40 °C to +75 °C
- Conformal coating on request
- Customer specific, low cost assembly versions
- RoHS compliant

The CP11 is a 6U CompactPCI CPU board with integrated dual core Intel Core 2 Duo or Intel Core Duo Processor and dual Gigabit Ethernet PICMG 2.16 channels. The Intel dual core processor includes two optimized execution cores in a single processor case. This enables execution of parallel threads or applications on separate cores with dedicated CPU resources. The CP11 supports a 32- and 64-bit processor architecture. CP11 is designed to meet the requirements of markets such as automation, simulation/training, test and measurement, and military.

Based on the Intel Core Duo Processor, the platform is designed to support processor speeds from 1.06 GHz up to 2.0 GHz. The Intel Core 2 Duo runs at 1.5 GHz and 2.16 GHz. Rugged needs are addressed with an optional extended temperature range of up to -40 °C to +75 °C (depends on selected board options) and conformal coating is available on request.

The CP11 provides a unique feature set, including up to 4 GB of DDR2 SDRAM

(200 MHz) with enhanced ECC, four independent on-board PCI buses, system host and peripheral mode support for the CP11 backplane, two PMC interfaces (64-bit/133 MHz and 32-bit/33 MHz). Instead of the PMC1, a PCI Express™ based XMC interface is available on request. A high level of functional integration (two Gigabit Ethernet, one Fast Ethernet, two serial interfaces (RS-232 or RS-422/485), USB 2.0, integrated HDD or Flash drive) gives users the freedom to use the PMC interfaces for their application specific I/O. The VGA/DVI interface is supported through a high performance 2D/3D ATI® video controller capable of driving two displays in parallel.

Versions with front panel I/O are available in various configurations with one or two PMC interfaces. The PMC1 interface can be ordered as an XMC interface instead.

Supported operating systems are Windows®, Linux® and VxWorks®. Integrity is available on request.



CP11 Dual Slot 6U CompactPCI® SBC with Dual Core 32- or 64-bit Processor

Specifications

Processor – µFCBGA, Low Power Design

- Scalable processing power with flexible processor design
- Supports 32-bit and 64-bit processor architecture
- 64-bit: Intel Core 2 Duo processor: 1.50 GHz and 2.16 GHz
- 32-bit: Intel Core Duo processor: 1.66 GHz and 2 GHz
- 32-bit: Intel Celeron M processor ULV 423: 1.06 GHz
- High efficiency on-board switching regulator (DC/DC)
- Fanless cooling with heat sink
- * Contact factory for latest CPU versions

Processor	FSB MHz	Level 2 Cache
Core 2 Duo	667	4 MB
Core Duo	667	2 MB
Celeron M	533	1 MB

CompactPCI – PLX 6466 PCI-to-PCI Bridge

- PICMG 2.0 R3.0 compliant CPCI local bus standard
- 64-bit PCI-to-PCI bridge for up to 8 slots (33 MHz) or 5 slots (66 MHz)
- Supports System Host and Peripheral Mode
- J1+2, 2 mm pin and socket connectors (IEC-1076-4-101)

Chipset – Intel E7520/6300ESB

- Four parallel PCI Express connections to major components for maximum I/O throughput

Memory – DDR2-400

- High-speed registered DDR2 SDRAM with 400 MHz
- 144-bit wide with enhanced error correction (ECC)
- 32-bit CPU: up to 4 GB soldered memory (usable size depends on operating system)
- 64-bit CPU: up to 4 GB soldered memory

Dual Gigabit Ethernet – Intel 82571EB

- Dual Channel Ethernet Controller with PCI Express x4 interface
- 10/100/1000BaseT auto-negotiation
- Front and/or rear I/O
- Compliant to PICMG 2.16

Fast Ethernet – Intel 82551QM

- Single channel Ethernet Controller
- 10/100BaseT auto-negotiation
- Front I/O

Hard Disk or Flash Drive

- Internal 2.5" UDMA100 IDE hard disk or Flash Drive for extended temperature range and higher shock/vibration immunity)

PMC Extension Slots – IEEE P1386/1386.1

- PMC1 (64-bit/133 MHz) and PMC2 (32-bit/33 MHz), XMC (PCIe x4) on PMC1 available on request.
- Enhancement to processor PMC standard VITA 32-2003 (non-monarch)
- PMC1 signaling is 3.3 V only, PMC2 signaling is 5 V tolerant.

Serial I/O – RS232/422/485

- Two async. 16550 compatible full duplex serial channels at rear I/O
- High-speed transfer up to 115.2 Kbaud with 16 byte FIFOs
- User selectable RS232/422/485 interface
- COM1 optionally available at front via RJ45

VGA and DVI – ATI® X300™

- 256-bit 3D and 2D graphics accelerator
- On-chip 32 MB memory
- PCI Express x4 interface
- Dual CRT/Simultaneous Dual Display (same or different surfaces)
- Integrated 300 MHz Palette DAC for analog VGA monitors up to 1280 x 1024
- Single channel DVI-I interface PanelLink® for TFT displays up to 1280 x 1024 true color (EDID displays PnP supported)
- Fully compliant support for OpenGL for all Windows operating systems and Linux
- Versions with front or rear I/O

EIDE – 6300ESB

- Ultra ATA/100 sync. DMA mode up to 100 MB/s
- PIO mode 4 and bus master IDE up to 16 MB/s
- One device via on board connector and two devices via rear I/O available

General Purpose I/O

- 8 GPIO (input or output) pins
- Software configurable

USB 2.0 – 6300ESB

- Two USB 2.0 channels on rear I/O
- Two USB 2.0 channels on front

Keyboard, Mouse

- Via USB
- Legacy PS/2 controller emulation

Real-time clock

- RTC 146818 compatible
- Li-battery

CMOS RAM

- 242 bytes non-volatile CMOS RAM for BIOS use

EEPROM

- 512 Kbit serial EEPROMs for non-volatile user data

Floppy

- Via USB

Watchdog

- Intel TCO timer
- Intel 6300ESB watchdog

Timer

- Integrated in 6300ESB chipset
- Legacy PC-AT timer
- High Precision Event Timer (HPET)

Temperature Sensors

- CPU die and pcb temperature software readable in the range of -55 °C to +125 °C

LED (not in conduction cooled style)

- Front panel ACPI System Status Indicator LED (red/amber/green)
- CompactPCI hot swap (blue) on front panel

Audio

- Line In, CD In
- Headphone, SPDIF Out
- AC97 link with codec



CP11 Dual Slot 6U CompactPCI® SBC with Dual Core 32- or 64-bit Processor

Hot Swap - compliant to PICMG 2.1

- Peripheral mode: Full CompactPCI Hot Swap
- System Host mode: CompactPCI ENUM# event supported through ACPI or legacy driver

BIOS Features

- AMI BIOS Core 8, in-system programmable Flash ROM
- Automatic system configuration
- Integrated VGA, SATA RAID and Ethernet PXE ROM
- USB Mass Storage support
- Password protection
- Headless support
- Remote console through serial port

Software

- The following software is supported to the extent listed below

OS	On Request	Planned	Available
Windows		√	
Linux			√
VxWorks		√	
Integrity	√		

Front and Rear I/O (with transition module CTM17)

- The pin outs of the transition module connectors (rear I/O) correspond to standard PC connectors (press-fit cables).

Function	Front Style 1 / 3	Rear J3 / J4 / J5
DVI-I	-	√ ¹
VGA	√	√ ¹
Gigabit Ethernet 1	√ ²	√ ²
Gigabit Ethernet 2	√ ²	√ ²
Fast Ethernet	√	-
Reset	√	√
LEDs	√	√
USB 2.0 1-4	1-2	3-4
IDE primary	onboard	
IDE secondary		√
SATA 1		√
SATA 2		√
COM 1-2	1	1, 2
Audio		√
GPIO (8 pins)	-	√
PMC 1 (XMC on req.)	√	√
PMC 2 I/O	√	√

¹Rear DVI-I connector for DVI and VGA
²Either front or rear as an order option

Styles

Function	Style 1	Style 3
Front Panel	yes	yes
Parts Soldered	yes	yes
Li-Battery	yes	yes
Ext. Temperature	no	yes

Power Requirements

- +5 V, +3.3 V, +12 V Required
- 12 V If required by mounted PMC module

Power Consumption - typical operating current

- Without keyboard, hard disk, modules, Ethernet (no link), measured at DOS prompt, no power savings. 512 MB memory option.

Processor	5 V	3.3 V	Total Power
Core 2 Duo, 2.16 GHz	4.9	8.4	52.2
Core 2 Duo, 1.5 GHz	3.1	8.4	43.2
Core Duo, 2.00 GHz	4.0	8.4	47.7
Core Duo, 1.66 GHz	2.7	8.4	41.2
Celeron M, 1.06 GHz	1.2	8.4	33.7

- Without keyboard, hard disk, modules, Windows XP, 3D graphics active. Both Gigabit Ethernet channels linked, CPU running at instruction mix for maximum power consumption. 2 GB memory option.

Processor	5 V	3.3 V	Total Power
Core 2 Duo, 2.16 GHz	7.1	10.1	68.8
Core 2 Duo, 1.5 GHz	4.1	10.1	53.8
Core Duo, 2.00 GHz	5.8	10.1	62.3
Core Duo, 1.66 GHz	3.7	10.1	51.8
Celeron M, 1.06 GHz	1.4	10.1	40.3

Power Allowances - PMC/XMC slots

- +5 V, +3.3 V: Total power max. 7.5 W
- ±12 V: 100mA each

Mechanical - PICMG 2.0

- 6U, 2 slots wide, (233 x 160 x 40) mm with Flash Drive or hard disk

Temperature

- Note: For detailed information about the operating temperature behavior of the board of any style it is absolutely necessary to consult the manual. The processor type and speed, altitude, the use or not use of Ethernet and video, ambient conditions and the type of cooling influences the board temperature range.

Temperature

- All values under typical conditions without PMC module
- | Range | Operating | Storage |
|----------|------------------|------------------|
| Standard | 0 °C to +55 °C | -40 °C to +85 °C |
| Extended | -40 °C to +75 °C | -40 °C to +85 °C |

	Operating	Storage
Humidity	5 - 95 % @ 40 °C	5 - 95 % @ 40 °C
Altitude	15,000 ft. (4.5 km)	40,000 ft. (12 km)

Shock and Vibration

- Designed to meet VITA47 class EAC1 and EAC3

VITA 47

- Designed to meet VITA47 class EAC1 and EAC3

MTBF

- Calculations are available in accordance with MIL-HDBK-217. Please contact GE Intelligent Platforms.

Safety

- Designed to meet standard UL1950, CE class A, FCC-A



CP11 Dual Slot 6U CompactPCI® SBC with Dual Core 32- or 64-bit Processor

Block Diagram

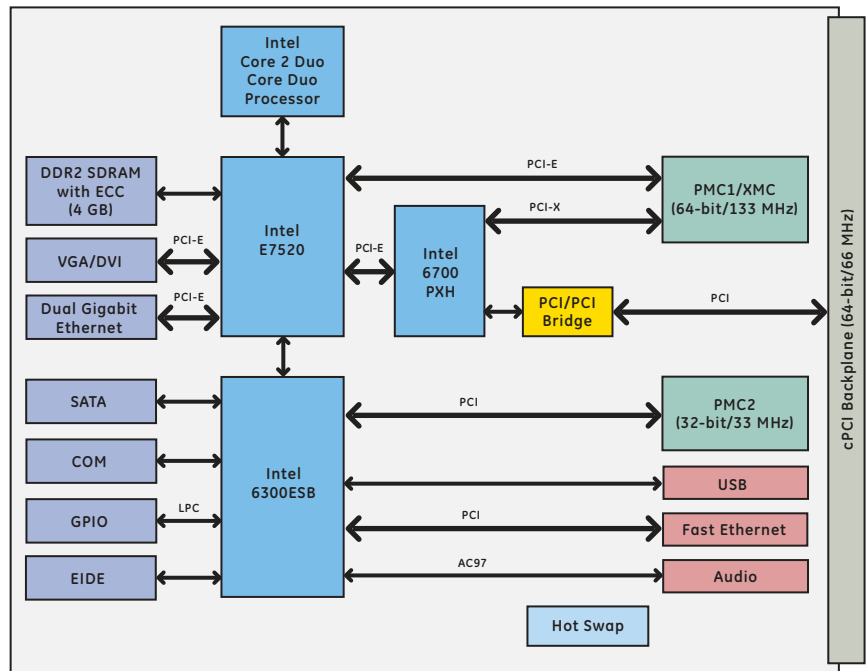

Ordering Information

Hardware Accessories

CTM17: I/O transition module for 6U backplane (IEEE 1101.11-1998 compliant)

SCC784UE05CP11R: 7U, 19" starter cage with 5 CPCI slots, backplane, HDD, DVD, power supply

Operating Systems

Extensive operating systems support is available, (see page 2 of this document).

Chassis with power supplies, backplanes and drives on request.

For detailed information and further options, contact GE Embedded Systems.

About GE Intelligent Platforms

GE Intelligent Platforms, a General Electric Company (NYSE: GE), is an experienced high-performance technology company and a global provider of hardware, software, services, and expertise in automation and embedded computing. We offer a unique foundation of agile, advanced and ultra-reliable technology that provides customers a sustainable advantage in the industries they serve, including energy, water, consumer packaged goods, government and defense, and telecommunications. GE Intelligent Platforms is a worldwide company headquartered in Charlottesville, VA and is part of GE Home and Business Solutions. For more information, visit www.ge-ip.com.

GE Intelligent Platforms Contact Information

Americas: **1 800 433 2682** or **1 434 978 5100**

Global regional phone numbers are listed by location on our web site at www.ge-ip.com/contact

www.ge-ip.com

