

PART NAME

VALU/LINE SERIES

PART No.

HC-14100 to HC-14105

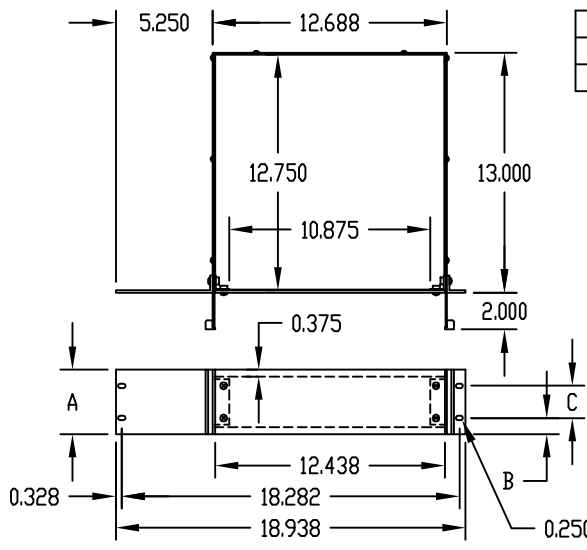

PART No.	DIM. 'A'	DIM. 'B'	DIM. 'C'	DIM. 'D'
HC-14100	3.500	0.875	1.750	2.750
HC-14102	5.250	1.500	2.250	3.500

UNITS ARE SHIPPED UNASSEMBLED

OPTIONAL OUTER BRACKETS FOR MOUNTING IN STANDARD E.I.A. 19" CABINETS (SUPPLIED)

OPTIONAL SELF-ADHESIVE RUBBER FEET (SUPPLIED)

LOAD RATING: 25 LBS. MAX.

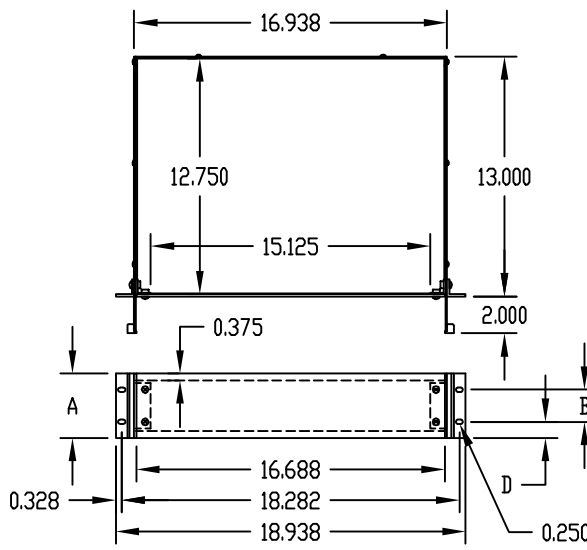
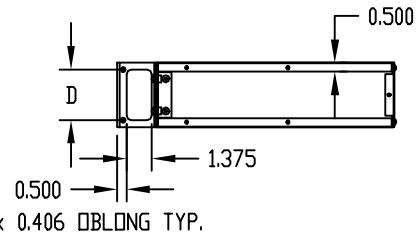

PART No.	DIM. 'A'	DIM. 'B'	DIM. 'C'	DIM. 'D'
HC-14101	3.500	1.750	2.750	0.875
HC-14103	5.250	2.250	3.500	1.500
HC-14104	7.000	4.000	3.500	1.500

MATERIAL:

FRONT PANEL _____ 0.125 THK. ALUMINUM

OUTER BRACKET _____ 11 GA. STEEL

INNER BRACKET & SIDE _____ 0.090 THK. ALUMINUM

BACK & COVER _____ 0.050 THK. ALUMINUM

HANDLE _____ ALUMINUM EXTRUSION

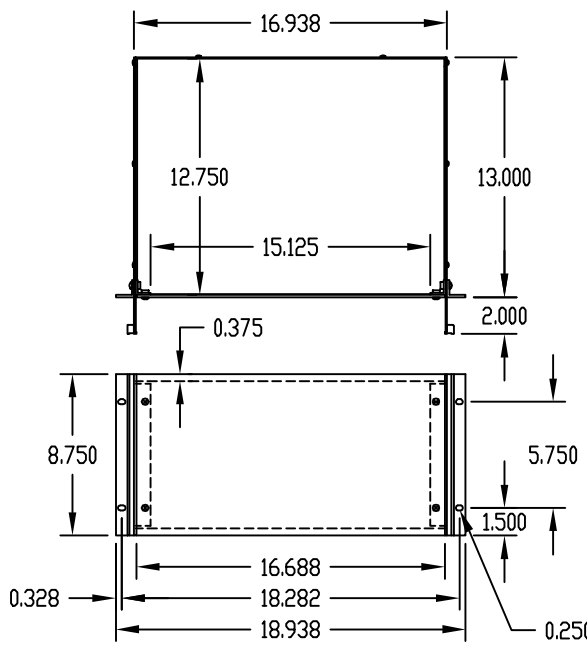
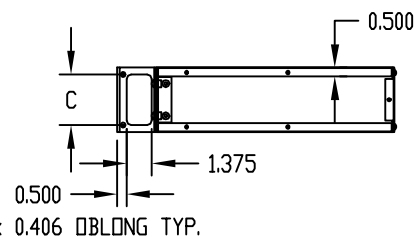

PART No.
HC-14105

FINISH:

BACK & COVER _____ SMOOTH WHITE

SIDE & OUTER BRACKET _____ WHITE TEXTURE

FRONT PANEL & INNER BRACKET _____ NATURAL

HANDLE _____ BRUSHED, ETCHED & CLEAR ANODIZED

FEET _____ BLACK

