

Description:

SNP-956X-M series is a 60W, universal input switching power supply. It is with various output options, which includes triple outputs, dual outputs and single output. It is designed to comply with UL2601-1, EN 60601-1. It is ideal for small digitally based systems used in medical and dental patient environment.

Model available:

- SNP-9561-M for 5V/5A, 12V/2.3A, -12V/0.5A
- SNP-9563-M for 5V/5A, 12V/2.8A
- SNP-9566-M for 5V/12A
- SNP-9567-M for 12V/5.5A
- SNP-9568-M for 15V/4.5A
- SNP-9565-M for 18V/3.75A
- SNP-9569-M for 24V/2.75A

General Specifications:

Input voltage 90VAC to 264VAC
 Input frequency 47Hz to 63Hz
 Inrush current less than 30A at 115VAC
 (Cold start) less than 60A at 230VAC
 Efficiency higher than 70%
 at rated load and 115VAC
 Hold up time 20mS (typ.)
 at rated load and 115VAC
 Over load protection auto recovery
 Short circuit protection auto recovery
 Over voltage protection auto recovery

Operating temperature 0 to 50°C, rated load
 Cooling free air convection
 Storage temperature -20°C to +85°C
 EMS IEC-801-2 8KV air discharge
 IEC-801-3 3V/m
 IEC-801-4 0.5KV
 EMI meet FCC docket 20780 curve "B"
 EN55011 "B"
 EN61000-3-2 "A"
 Safety UL 2601-1 (UL file no. E158990)
 CSA 601-1 (CUL)
 EN60601-1

Mechanical Specifications:

SNP-9561-M

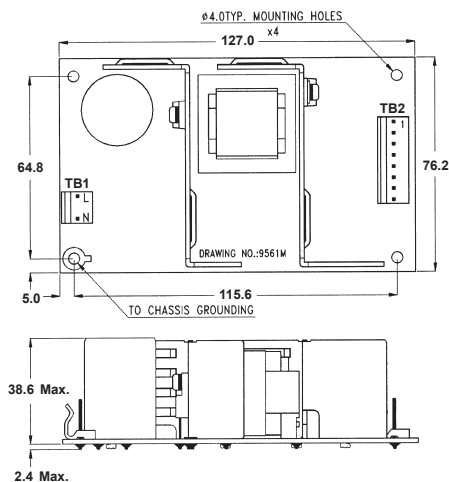

Note:

1. Dimensions shown in mm as left. Tolerance specified is ± 0.4 mm.
2. P.C.B. Size:
76.2 X 127 X 38.6 (mm)
3 X 5 X 1.519 (inch)
3. Mounting Hole:
64.8 x 115.6 (mm)
2.55 x 4.55 (inch)
4. Packing:
Net weight: 290 g approx. / unit
Gross weight: 12.5 kg approx. / carton, 36 units / carton
Carton size (mm): 339 (L) x 339 (W) x 327 (H)
5. Connectors:
TB1 : Molex 5277-2 or equivalent for AC input
TB2 : Molex 5273-X or equivalent for DC output
6. DC output Pin Assignment:

PIN	1	2	3	4	5	6	7	8
MODEL								
SNP-9561-M	+5V	+5V	GND	GND	+12V	+12V	-12V	NC
SNP-9563-M	+5V	+5V	GND	GND	GND	GND	+12V	+12V
SNP-9566-M	+5V	+5V	+5V	+5V	GND	GND	GND	GND
SNP-9567-M	+12V	+12V	+12V	GND	GND	GND		
SNP-9568-M	+15V	+15V	+15V	GND	GND	GND		
SNP-9565-M	+18V	+18V	+18V	GND	GND	GND		
SNP-9569-M	+24V	+24V	+24V	GND	GND	GND		

-James-



THE RELIABLE SOURCE

Medical Family (Universal)

60W
SNP-956X-M Series

Output Specifications:

MODEL NO.	OUTPUT RAIL	LOAD			VOLTAGE ACCURACY	RIPPLE NOISE	LINE REG.	LOAD REG.
		MIN.	RATED	PEAK				
SNP-9561-M	+5V	0A	5A	8A	+4.95V~+5.05V(adj)	50mVpp	±1%	±1%
	+12V	0A	2.3A	3.5A	+11.4V~+12.6V	100mVpp	±1%	±5%
	-12V	0A	0.5A	0.5A	-11.40V~-12.6V	100mVpp	±1%	±5%
SNP-9563-M	+5V	0A	5A	8A	+4.95V~+5.05V(adj)	50mVpp	±1%	±1%
	+12V	0A	2.8A	5.5A	+11.40V~+12.60V	100mVpp	±1%	±5%
SNP-9566-M	+5V	0A	12A		+4.75V~+5.25V(adj)	50mVpp	±1%	±1%
SNP-9567-M	+12V	0A	5.5A		+11.80V~+12.20V(adj)	100mVpp	±1%	±1%
SNP-9568-M	+15V	0A	4.5A	7A	+14.85V~+15.15V(adj)	100mVpp	±1%	±1%
SNP-9565-M	+18V	0A	3.75A		+17.82V~+18.18V(adj)	100mVpp	±1%	±1%
SNP-9569-M	+24V	0A	2.75A	4.3A	+23.76V~+24.24V(adj)	100mVpp	±1%	±1%

Note:

1. Each output can provide up to peak load temporarily. Continuous staying in more than rated load will reduce the reliability.
2. Voltage accuracy is measured with all outputs set at 60% rated load and main output is adjusted to +/- 1%.
3. Line Regulation measuring is done at rated loading and + -10% of input voltage changing.
4. Load Regulation measuring is done by changing the measured output loading + -40% from 60% rated load, and keep all other outputs at 60% rated load.
5. Ripple & Noise measuring is done by 15MHz band width limited oscilloscope and terminated each output with a 0.47uF capacitor at rated loading.
6. Efficiency is measured at rated load.
7. Hold Up Time is measured from the end of the last full charging pulse to when the main output drop down to 95% output voltage.