

ABSOLUTE™

Temperature Control System

DESCRIPTION

The ABSOLUTE™ Temperature Control System provides accurate and stable temperature control of liquid source chemicals. Five different models provide temperature control through the range of 10° - 90°C, with an accuracy of $\pm 0.2^\circ\text{C}$.

FEATURES AND BENEFITS

- Modular design for easy installation
- Microprocessor-based control circuitry for accurate and stable temperature control
- Electronic and visual (sight glass) level sense (for monitoring chemical levels)
- Removable source cup permits safe container installation from the front of the unit
- Full range of safety interlocks
- DDC interface for remote control and monitoring
- Holds 1500cc quartz or 1.2 liter stainless steel containers
- Stainless steel versions incorporate level sense and integrated lid heater
- Trans-LC® version eliminates all spark sources and reduces over temperature cutout interlock

APPLICATIONS

- Temperature control for CVD source chemicals (i.e. TEOS, ZTOMCATS®, LTO-410™, TMB, TMPI)
- Temperature control for diffusion and oxide passivation source chemicals (i.e. Trans-LC, TCA, POCl₃, and PBr₃ and BBr₃)

RELATED PRODUCTS

Delivery Containers

- 1500cc Quartz Breakseal Containers
- 1.2 liter Stainless Steel Containers

Delivery Equipment

- Serves as temperature controller for the VMDOT™ Delivery System

Refill Equipment

- Transfill® II Automated Chemical Refill System
- UltraFill™ Automated Chemical Refill System



ATCS with 1500cc patented breakseal quartz bubbler.

ABSOLUTE™

ABSOLUTE SYSTEM SPECIFICATIONS

PERFORMANCE

Temperature Control:	Temp Accuracy:	± 0.2°C of setpoint
Standard Temperature Model: 10°C* to 60°C	Temp Stability:	± 0.1°C
High Temperature Model: 40°C to 90°C	Readout Resolution:	0.1
Trans-LC Model: 10°C to 22°C	Temp Cutout (std):	70°C
	Temp Cutout (Trans-LC):	50°C
	Temp Cutout (high temp):	110°C

LIQUID LEVEL SENSE

Quartz Breakseal Container:

Discrete level sensors at 100%, 50%, 25% and 15%.
Backlit sight glass for visual inspection of liquid level.

Stainless Steel Container:

Discrete level sensors for indications at 100%, 75% and 15%.

ALARMS

Liquid Level Alarm:

Alarm activated when liquid level reaches 15% full.

Temperature Alarm:

Alarm is activated when the sensed temperature is not within ± 2°C of the temperature setpoint.
(± 5°C for Trans-LC unit)

Alarm Indicators:

All alarm conditions generate an audio alarm, flashing LED display with alarm condition, and an alarm output through the DDC interface. (The audio alarm can be silenced for 30 minute intervals.)

DIMENSIONS

ABSOLUTE Electronics Module:	ABSOLUTE Base Unit
Height: 233.7mm (9.20 in)	Height: 233.7mm (9.20 in)
Width: 63.5mm (2.50 in)	Width: 209.6mm (8.25 in)
Depth**: 260.4mm (10.25 in)	Depth**: 262.9mm (10.35 in)
	Source elevation***: 62.5mm (2.5 in)

WEIGHT

ABSOLUTE Base Unit:	6.7kg**** (14.9 lbs)
ABSOLUTE Electronics Module:	4.8kg (10.5 lbs)

MOUNTING

- ABSOLUTE must be mounted on a level, low vibration surface.
- ABSOLUTE base unit should be secured to mounting surface to prevent it from sliding when removing and installing the source cup.
- ABSOLUTE electronics module can be remoted up to 4.84 meters (16 feet) away from the base unit.

POWER REQUIREMENTS

- 90 - 154VAC 50/60 Hz 275VA max
- 180 - 264VAC 50/60 Hz 275VA max

DDC INPUTS

- Analog Temperature Setpoint

* Minimum cooling capability is 15°C below ambient temperature.

** Add a minimum of 78mm (3in) to depth measurements for cable connection clearance.

*** Overall height = 62.5mm (2.5in) + source height.

**** Not including weight of source and chemical.

ABSOLUTE™

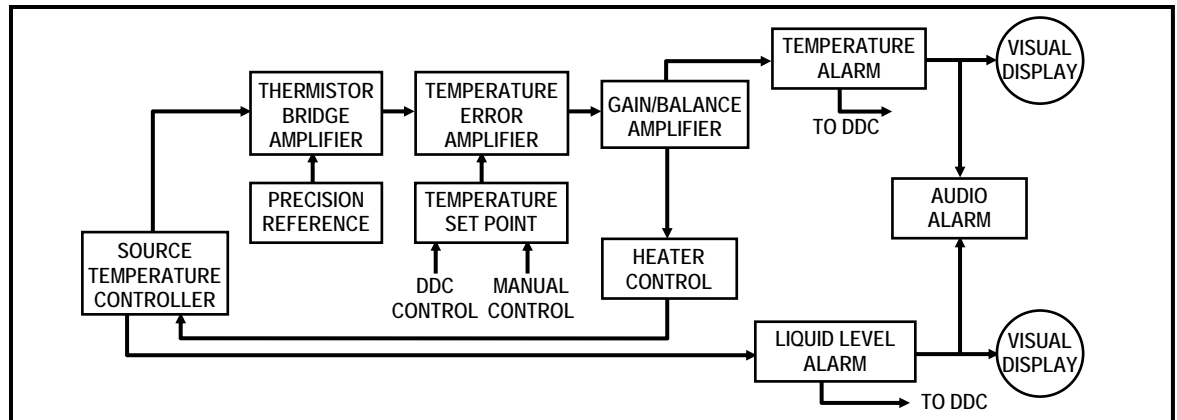

DDC OUTPUTS

- Analog Temperature Output
- Analog Level Output
- Temperature Alarm
- Liquid Level Alarm
- Any Alarm

CABLE LENGTH

- DDC Cable 20 Conductor Shielded: 6.10 meters (20ft) 20-conductor shielded
- ABSOLUTE Interconnect Cable: 456.85mm (18in) standard
 - Cable lengths up to 6.10 meters (20ft) are available upon request.

SOURCE CONTAINERS

The ABSOLUTE is fully compatible with Schumacher 1500cc quartz and 1.2 liter stainless steel containers.

1.2 Liter stainless steel container:*

Standard Configuration (BK1200SS Series)

- Manual inlet/outlet valves
- VCR inlet/outlet connectors
- Level Sense Probe

Integral Lid Heater Configuration (BK1200SSV)

- Pneumatic outlet valve
- 1/2" male VCR outlet connector
- Level sense probe

TransFill Host Container (BK1200SSR)

- Designed for automatic refill
- Pneumatic valves, VCR connectors
- Continuous and discrete level sense probes included

1500cc Quartz Containers:

D-Series Quartz Container (BK3D1)

- Teflon inlet/outlet valves
- 1/4" inlet and 3/8" outlet connectors (for teflon tubing)

R-Series Quartz Container (BK3R1)

- Designed for Automatic Refill
- Pneumatic Teflon Control Valves
- Continuous and discrete level sense probes included

S-Series Quartz Container (BK3S1, BK3S2)

- SS VCR adaptors

* Refer to 1.2 liter Stainless Steel Product Data Sheet for additional information on specific configurations.

ABSOLUTE™

PRODUCT DESCRIPTION	PART NUMBER	TEMPERATURE RANGE	SOURCE CONTAINER
ABSOLUTE Std Temp Quartz	ATCS15	10 to 60°C	1500cc Quartz (BK3D1, BK3S1/2)
ABSOLUTE Std Temp SS System	ATCS15-SS	10 to 60°C	1.2 liter SS (BK1200SS Series)
ABSOLUTE High Temp Quartz System	ATCS15HT	40 to 90°C	1500cc Quartz (BK3D1, BK3S1/2)
ABSOLUTE High Temp SS System	ATCS15HT-SS	40 to 90°C	1.2 liter SS (BK1200SSV Series)
ABSOLUTE Trans-LC Quartz System	ATCS15TLC	10 to 22°C	1500cc Quartz (BK3D1)

APPLICATION SUPPORT

Schumacher maintains an active research program aimed at developing improved source chemicals, processes and delivery equipment. Our technical staff is available to assist you with process problems and safety concerns. For more information please call 1-760-931-9555 or 1-800-545-9242.

ORDERING INFORMATION

Please contact your Schumacher sales representative for ordering information or call Schumacher at 1-760-931-9555 or 1-800-545-9242.



For More Information

If you would like additional information or technical assistance in preparing specific formulations, write or call Air Products and Chemicals, Inc. at the following location.

Schumacher
1969 Palomar Oaks Way
Carlsbad, CA 92011
Tel: (800) 545-9241
www.airproducts.com/electronics

tell me more
<http://www.airproducts.com/electronics>