

# **General Standards Corporation**

**High Performance Bus Interface Solutions**

## ***PMC-16A04MF***

### **Four-Channel 16-Bit High-Speed Analog Output PMC Board** *With 400,000 Samples per Second per Channel, and Independent Clocking*

*(Photo not available)*

#### ***Features:***

- Four Precision 3-Wire Balanced Differential High-Speed Analog Output Channels;
- 16-Bit Resolution; D/A Converter per Channel
- Data Rates to 400 K-Samples per Second per Channel; 800 KSPS Aggregate Rate
- Output Ranges of  $\pm 12V$ ,  $\pm 10V$  or  $\pm 5V$
- Four Independent 32 K-Sample Analog Output FIFO Buffers
- Output Data Buffer Sizes Adjustable from Four Samples to up to 32 K-Samples
- High Stability Timebase; 20PPM
- Continuous and Burst Clocking Modes
- Seamless Waveform Sequencing
- Data Rates Controlled by Independent Internal Clocks, or by an External Clock
- Supports Multiboard Synchronization;
- Software-Selectable TTL or Differential External Clock I/O
- Internal Autocalibration of All Channels
- High Accuracy; 0.023% FSR max error on  $\pm 10V$  Range, INL = 0.007%
- Fast Settling; 5  $\mu s$  to 0.1%; 8  $\mu s$  to 0.01%; with No-filter Option
- Bidirectional Byte-Wide Digital Port

#### ***Applications:***

- |                            |                       |                      |
|----------------------------|-----------------------|----------------------|
| ✓ Precision Voltage Source | ✓ Acoustic Research   | ✓ Waveform Synthesis |
| ✓ Industrial Robotics      | ✓ Process Monitoring  | ✓ Acoustic Research  |
| ✓ Audio Synthesis          | ✓ Arbitrary Functions | ✓ Environmental Test |

### ***Preliminary***

REV- 051804

---

## **General Standards Corporation**

8302A Whitesburg Drive · Huntsville, AL 35802  
Phone: (256) 880-8787 or (800) 653-9970 FAX: (256) 880-8788

# General Standards Corporation

## High Performance Bus Interface Solutions

### Functional Description:

The PMC-16AO4MF board provides four independent 3-wire balanced differential 16-bit D/A converter channels, and all supporting functions necessary for adding precision high-speed analog output capability to a PMC host. The board is functionally compatible with the IEEE PCI local bus specification Revision 2.2, and supports the "plug-n-play" initialization concept. Unique FIFO buffer controls support the seamless sequencing of successive waveforms. In less demanding applications, the outputs can be updated individually. Both TTL and differential I/O ports support multiboard synchronization.

A PCI interface adapter provides the interface between the controlling PCI bus and the internal local controller through a 16-bit local bus (Figure 1). Four analog output channels are controlled through independent analog output FIFO buffers, and can be updated either simultaneously or sequentially. The clocking rate for each output channel can be controlled either by a dedicated internal rate generator, or by an external clock. The local controller manages all local configuration and data manipulation functions, including autocalibration. Analog output levels are initialized to zero (midrange).

Internal autocalibration networks permit calibration to be performed without removing the board or host from the system. This feature produces the optimum calibration situation, in which the board is calibrated in its actual operating environment,

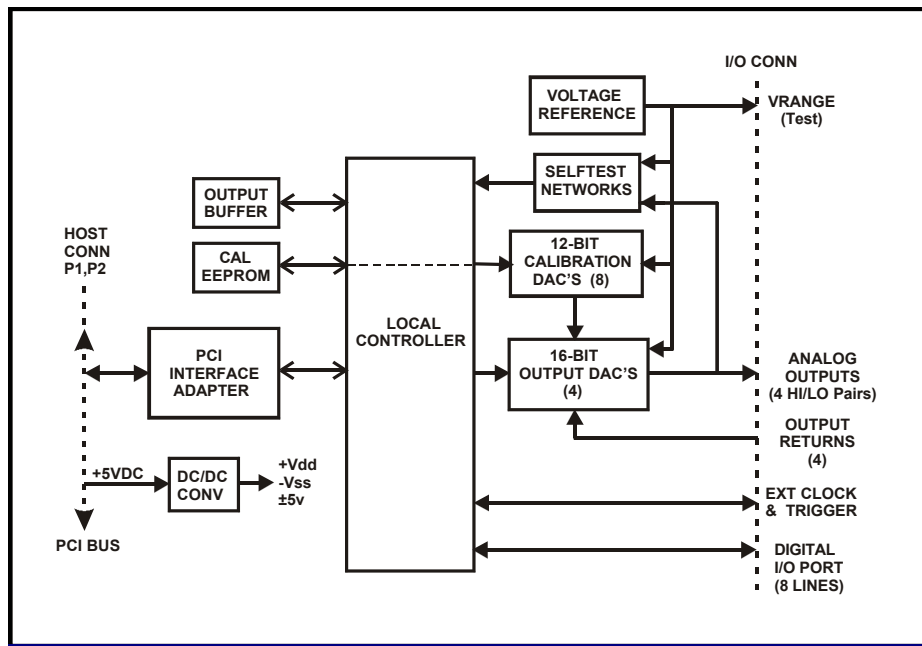

Figure 1. PMC-16AO4MF Board; Functional Organization

The board is designed for minimum off-line maintenance, and includes internal monitoring features that eliminate the need for disconnecting or removing the module from the system for calibration. All input and output system connections are made through a single I/O connector. Power requirements consist of +5 VDC in compliance with the PCI specification, and operation over the specified temperature range is achieved with conventional convection cooling.

# General Standards Corporation

## High Performance Bus Interface Solutions

<b>ELECTRICAL SPECIFICATIONS</b>
----------------------------------

At +25 °C, with specified operating voltages

**❑ Output Characteristics:**

Configuration:	Four balanced differential 3-wire (true/complement) analog output channels, with a dedicated 16-Bit DAC per channel
Voltage Ranges:	Factory configured as ±12 Volts, ±10 Volts or ±5 Volts
Output Resistance:	Output: 1.0 Ohm maximum
Output protection:	Withstands sustained short-circuiting to ground without damage
Load Current:	Zero to ±5 milliamps
Load Capacitance:	Stable with zero to 2000 pF shunt capacitance
Settling Time:	No Filter :        5 us to 0.1%,     8 us to 0.01%
	10 kHz Filter:    130 us to 0.1%,   160 us to 0.01%
Noise:	No Filter:         4 mVRMS, 10 Hz - 100 KHz
	10 kHz Filter:    2 mVRMS, 10 Hz - 100 KHz
Glitch Impulse:	±5V Range:                5 nV-Sec
	±10V, ±12V Ranges:    8 nV-Sec

**❑ Transfer Characteristics:**

Resolution:	16 Bits (0.0015 percent of FSR)		
Sample Clocking Rate:	Master Rate Clock:	460 to 400,000 samples per second per channel	
	Adjustable-Rate Clock:	460 to 375,000 samples per second per channel	
	External Rate Clock:	Zero to 375,000 samples per second per channel.	
DC Accuracy: (Max error, no-load)	<u>Range</u>	<u>Midscale Accuracy</u>	<u>±Fullscale Accuracy</u>
	±12V	±2.5mv	±5.2mv
	±10V	±2.0mv	±4.6mv
	±5V	±1.5mv	±2.9mv
Bandwidth, -3dB:	No output filter option:	300 kHz typical	
	10 kHz filter option:	10 kHz typical (Single-pole lowpass)	
Crosstalk Rejection:	80 dB, DC-10 kHz		
Common Mode Offset:	±10mV from output return.		
Integral Nonlinearity:	±0.007 percent of FSR, maximum		
Differential Nonlinearity:	±0.003 percent of FSR, maximum		

# General Standards Corporation

## High Performance Bus Interface Solutions

### ❑ Operating Modes and Controls

Sample Clock Source: Internal rate generators, external hardware clock input, or software clock. The external clock output can be used for synchronization of multiple PMC-16AO4MF boards.

Each output channel can be clocked from an independent internal rate generator, or all channels can be clocked synchronously. Rate generator frequencies are independently adjustable from 16MHz to 32MHz with 0.2 percent resolution and 0.08 percent accuracy, and are derived from the local crystal-controlled master clock. Rate generator outputs are divided by independent 16-bit counters to provide the output channel clocks.

External sync I/O is software-selectable as either TTL-compatible, or as 2-wire LVDS differential pairs. The Sync I/O signals can be operated either as output clocks, or as burst triggers.

In addition to the basic rate generator frequencies that are adjustable with 0.2 percent resolution, up to eight custom fixed frequencies can be specified in the 16-32 MHz range as a factory option. Clock stability is 20PPM.

Burst Trigger: Software control bit, or external sync input.

Clocking Modes: Continuous or burst

Active Buffer Size: From 4 output values to 32K-values in 2:1 steps; each buffer.

Buffer Modes: Circular (closed) for periodic waveforms, or Open for continuous functions

Data Format: Software selected as offset binary or as Two's complement

### AUTOCALIBRATION

During autocalibration, each analog channel is calibrated to a single precision internal voltage reference that is adjustable with a single trimmer. Auto calibration has a typical duration of 3 seconds, and can be invoked at any time after initialization.

### PCI INTERFACE

### ❑ Analog Output Buffers

Analog output data is written to the board through four registers that serve as FIFO buffer ports. Each buffer is 17 bits wide, has a software-controlled capacity of from four output values to 32K values, and is right justified to the LSB in the D32 PCI data path. Output data is a 16-bit field that is software-configurable in either Two's complement or offset binary format. The 17th bit is used as an end-of-frame (EOF) flag for tracking functions through the buffer.

# General Standards Corporation

## High Performance Bus Interface Solutions

- Compatibility:** Conforms to PCI Specification 2.3, with 33MHz, 5V/3.3V, D32 transactions.  
 Supports "plug-n-play" initialization.  
 Single multifunction interrupt.  
 Supports block-mode DMA transfers to the output buffers as bus master.

### MECHANICAL AND ENVIRONMENTAL SPECIFICATIONS

**Power Requirements**

+5VDC ±0.2 VDC at 1.4 Amps maximum, 1.0 Amp typical. Outputs fully loaded.  
 Maximum Power Dissipation:           Side-1: 5.5 Watts maximum, 4.0 Watts typical  
   Side-2: 1.4 Watt maximum, 1.0 Watt typical.

**Physical Characteristics**

Height:        13.5 mm (0.53 in)  
 Depth:        149.0 mm (5.87 in)  
 Width:        74.0 mm (2.91 in)

**Environmental Specifications**

Ambient Temperature Range: Operating:  
   Commercial: 0 to +65 degrees Celsius inlet air  
   Ruggedized: \* 0 to +80 degrees Celsius inlet air  
   \* Industrial-temp components; conformally coated.

Storage:       -40 to +85 degrees Celsius

Relative Humidity:                            Operating: 0 to 80%, non-condensing  
   Storage: 0 to 95%, non-condensing

Altitude:        Operation to 10,000 ft.

Cooling:         Conventional convection cooling.

### ORDERING INFORMATION

Specify the basic product model number (PMC-16AO4MF), followed by an option suffix "A-B-C-D" as indicated in the table below. For example, model number PMC-16AO4MFIC-12V-NF-4CF describes an ruggedized board with a ±12 Volt output range, no output filters, and four custom frequencies.

Optional Parameter	Value	Specify Option As:
Operating Environment	Commercial Grade	A = (Blank)
	Ruggedized	A = IC
Output Range:	±5 Volts	B = 5V
	±10 Volts	B = 10V
	±12 Volts	B = 12V
Output Lowpass Filter:	No output Filter	C = NF
	10 kHz Output Filter	C = F
Custom Rate-Generator Frequencies: * (8 Maximum)	No custom frequencies	D = NCF
	Custom frequencies	D = (1-8)CF

\* Specify required frequencies and accuracies (±0.01 percent). Contact factory for availability.

# General Standards Corporation

## High Performance Bus Interface Solutions

### SYSTEM I/O CONNECTIONS

**Table 1. System Connector Pin Functions**

P5A		P5B	
PIN	SIGNAL	PIN	SIGNAL
1	ANA OUTPUT 00 LO	1	DIGITAL RTN
2	ANA OUTPUT 00 HI	2	DIGIO 00
3	OUTPUT RETURN	3	DIGITAL RTN
4	OUTPUT RETURN	4	DIGIO 01
5	ANA OUTPUT 01 LO	5	DIGITAL RTN
6	ANA OUTPUT 01 HI	6	DIGIO 02
7	OUTPUT RETURN	7	DIGITAL RTN
8	OUTPUT RETURN	8	DIGIO 03
9	VRANGE RETURN	9	DIGITAL RTN
10	VRANGE OUTPUT	10	DIGIO 04
11	VRANGE RETURN	11	DIGITAL RTN
12	OUTPUT RETURN	12	DIGIO 05
13	ANA OUTPUT 02 LO	13	DIGITAL RTN
14	ANA OUTPUT 02 HI	14	DIGIO 06
15	OUTPUT RETURN	15	DIGITAL RTN
16	OUTPUT RETURN	16	DIGIO 07
17	ANA OUTPUT 03 LO	17	DIGITAL RTN
18	ANA OUTPUT 03 HI	18	DIGITAL RTN
19	OUTPUT RETURN	19	DIGITAL RTN
20	OUTPUT RETURN	20	DIGITAL RTN
21	DIGITAL RTN	21	DIGITAL RTN
22	TTL SYNC INP L	22	TTL SYNC OUT L
23	DIGITAL RTN	23	DIGITAL RTN
24	TTL CLK INP L	24	TTL CLK OUT L
25	DIGITAL RTN	25	DIGITAL RTN
26	DIGITAL RTN	26	DIGITAL RTN
27	DIFF SYNC INP LO	27	DIFF SYNC OUT LO
28	DIFF SYNC INP HI	28	DIFF SYNC OUT HI
29	DIGITAL RTN	29	DIGITAL RTN
30	DIGITAL RTN	30	DIGITAL RTN
31	DIFF CLK INP LO	31	DIFF CLK OUT LO
32	DIFF CLK INP HI	32	DIFF CLK OUT HI
33	DIGITAL RTN	33	DIGITAL RTN
34	DIGITAL RTN	34	DIGITAL RTN

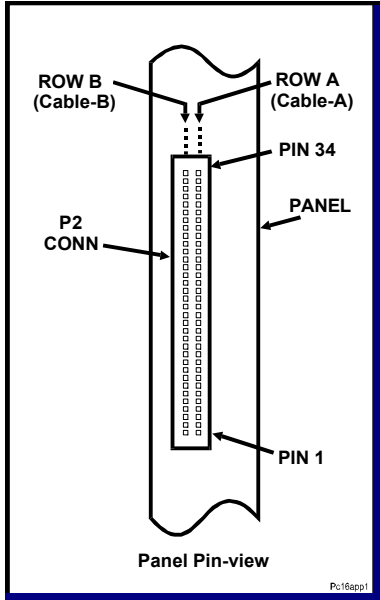

**Figure 2. System Input/Output Connector**

**System Mating Connector:**  
 68-Pin 2-row 0.050" dual-ribbon cable  
 socket connector: Metal Shell  
 KEL P/N 8840-068-174AD

Contact factory for availability of the 68-pin AMP SCSI-3 connector.

General Standards Corporation assumes no responsibility for the use of any circuits in this product. No circuit patent licenses are implied. Information included herein supersedes previously published specifications on this product and is subject to change without notice.