

Rosemount Manifolds

- *Factory assembled, leak-tested, and calibrated*
- *Full breadth of offering including integral, conventional, and inline designs*
- *Integral design enables “flangeless” valve integration*
- *2, 3, and 5 valve configurations*
- *Compact, lightweight design*
- *Easy in-process calibration*
- *Direct-mount capability*



Contents

Rosemount Manifolds Selection Guide	page 3
Valve Configuration	page 4
Specifications	page 6
Dimensional Drawings.	page 12
Ordering Information	page 22

Rosemount Manifolds

Factory assembled, leak-tested, and calibrated

Rosemount manifolds and transmitters can be pre-assembled at the factory, resulting in an integrated assembly that is easier to order, install, operate, and maintain.

Full breadth of offering

The Rosemount manifold product offering has a variety of process connections, platforms, and styles for use in any application.

Integral manifold design enables “flangeless” valve integration

Rosemount integral manifolds are assembled directly to the transmitter sensor body, eliminating the need for the transmitter flange. This results in a compact design that has 50% fewer leak points, requires less hardware, and is lighter and more streamlined compared to a traditional transmitter / flange / manifold interface.

Rosemount quality

Rosemount manifolds are designed and built to the same exceptional quality standards as Rosemount transmitters. From basic to demanding applications, Rosemount manifolds provide industry leading reliability at an exceptional value.

Rosemount Pressure Solutions

Rosemount 3051S Series of Instrumentation

Highest performing scalable pressure, flow and level measurement solutions drive better plant efficiency and more productivity. Innovative features include wireless, advanced diagnostics, and multivariable technologies.

Rosemount 3095 Mass Flow Transmitter

Accurately measures differential pressure, static pressure and process temperature to dynamically calculate fully compensated mass flow.

Rosemount 3051 Pressure Transmitter

Proven industry standard performance and reliability to increase plant profitability. Includes the most comprehensive offering to meet all application needs.

Rosemount 2051 Pressure Transmitter

Foundation for reliable measurement improves installation and maintenance practices. Common product family with a wide range of output protocols built on the flexible Coplanar™ platform.

Rosemount 304, 305 and 306 Manifolds

Factory-assembled, calibrated and seal-tested transmitter-to-manifold assemblies reduce installation costs.

Rosemount 1199 Diaphragm Seals

Provides reliable, remote measurements of process pressure and protects the transmitter from hot, corrosive, or viscous fluids.

Orifice Plate Primary Element Systems: Rosemount 1495 and 1595 Orifice Plates, 1496 Flange Unions and 1497 Meter Sections

A comprehensive offering of orifice plates, flange unions and meter sections that are easy to specify and order. The 1595 Conditioning Orifice provides superior performance in tight fit applications.

Annubar® Flowmeter Series: Rosemount 3051SFA ProBar®, 3095MFA Mass ProBar®, and 485

The state-of-the-art, fifth generation Rosemount 485 Annubar combined with the 3051S or 3095 MultiVariable transmitter creates an accurate, repeatable and dependable insertion-type flowmeter.

Compact Orifice Flowmeter Series: Rosemount 3051SFC, 3095MFC, and 405

Compact Orifice Flowmeters can be installed between existing flanges, up to a Class 600 (PN100) rating. In tight fit applications, a conditioning orifice plate version is available, requiring only two diameters of straight run upstream and two downstream.

ProPlate® Flowmeter Series: Rosemount 3051SFP ProPlate, 3095MFP Mass ProPlate, and 1195

These integral orifice flowmeters eliminate the inaccuracies that become more pronounced in small orifice line installations. The completely assembled, ready to install flowmeters reduce cost and simplify installation.

Rosemount Manifolds Selection Guide

ROSEMOUNT 304 CONVENTIONAL MANIFOLD

See "Ordering Information" on page 22.

- Attaches to transmitter flange
- 2, 3, and 5-valve configurations
- Traditional (Flange x Flange, Flange x NPT) & Wafer styles
- Factory assembled, seal-tested and calibrated

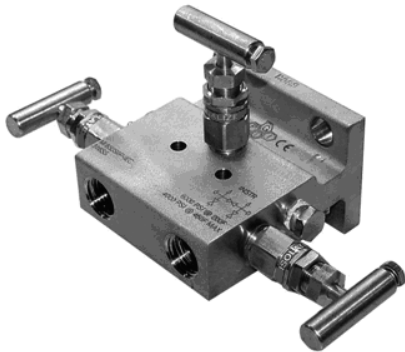

Rosemount 304 Conventional Manifold-Traditional Style



Rosemount 304 Conventional Manifold-Wafer Style

ROSEMOUNT 305 INTEGRAL MANIFOLD

See "Ordering Information" on page 22.

- Assembles directly to transmitter, eliminating need for flange
- 2, 3, and 5-valve configuration
- Available in Coplanar™ and traditional styles
- Compact, lightweight assembly
- Factory assembled, seal-tested and calibrated
- 50% fewer leak points than conventional transmitter / flange / manifold interface

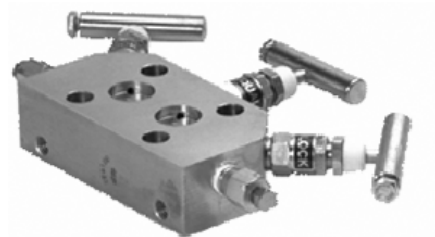

Rosemount 305 Integral Manifold Coplanar Style

ROSEMOUNT 306 INLINE MANIFOLD

See "Ordering Information" on page 22.

- Assembled directly to inline pressure transmitters
- Block-and-Bleed and 2-valve configurations
- Male or Female threaded NPT process connection



Rosemount 306 Inline Manifold

Rosemount Manifolds

Valve Configuration

BLOCK-AND-BLEED

The block-and-bleed configuration is available on the Rosemount 306 Manifold for use with inline gage and absolute pressure transmitters. A single block valve provides instrument isolation, and a plug provides drain/vent capabilities.

306 Manifold

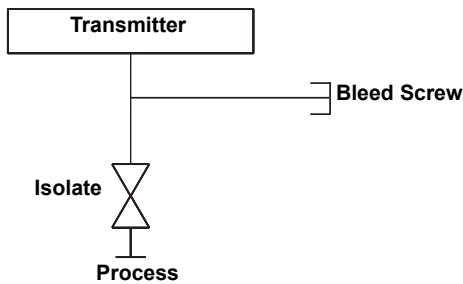

TWO-VALVE

The two-valve configuration is available on Rosemount 304, 305, and 306 Manifolds for use with absolute and gage pressure transmitters. A block valve provides instrument isolation, and a drain/vent valve allows venting, draining, or calibration.

304 Manifold

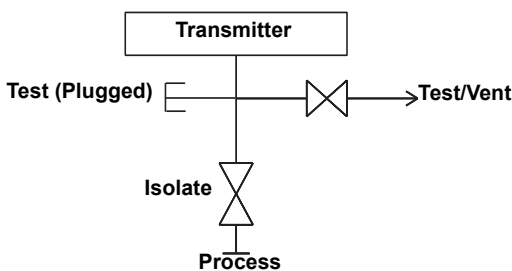

305 & 306 Manifolds

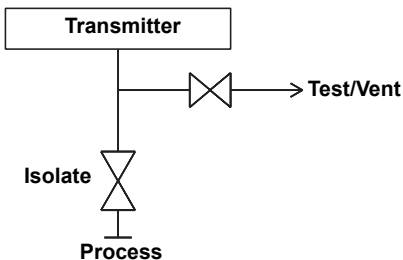

THREE-VALVE

The three-valve configuration is available on Rosemount 304 and 305 Manifolds for use with differential pressure and multivariable transmitters. Two block valves provide instrument isolation, and one equalize valve is positioned between the high and low transmitter process connections.

304 (Traditional) Manifold

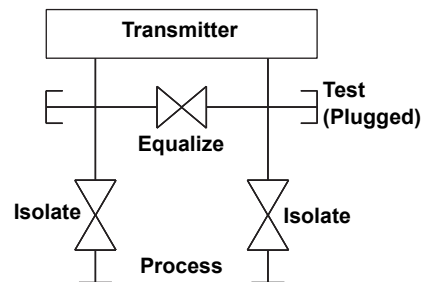

304 (Wafer) Manifold

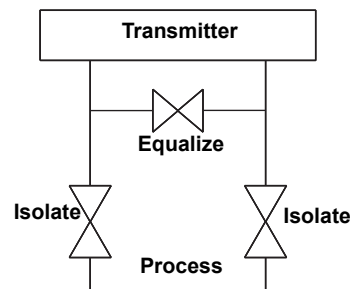

305 Manifold

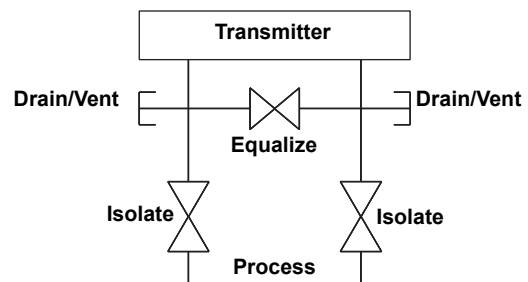

NOTE

Test/Vents receive plastic caps to protect threaded connections unless otherwise noted.

NOTE

Test (Plugged) connections receive 1/4-in. NPT plugs unless otherwise noted.

FIVE-VALVE

The five-valve configuration is available on Rosemount 304 and 305 Manifolds for use with differential pressure and multivariable transmitters. Two block valves provide instrument isolation, and one equalize valve is positioned between the high and low transmitter process connections. In addition, two drain/vent valves allow for controlled venting, 100% capture of vented or drained process, and simplified in-process calibration capability.

304 (Wafer) & 305 Manifolds

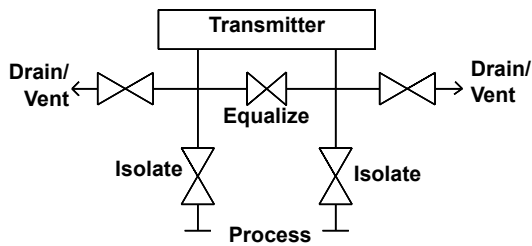

FIVE-VALVE NATURAL GAS

The five-valve natural gas configuration is available on the Rosemount 304 and 305 Manifolds for use with differential pressure and multivariable transmitters. Two block valves provide instrument isolation, and a single drain/vent valve allows for controlled venting, 100% capture of vented or drained process, and simplified in-process calibration capability. In addition, two equalize valves provide extra protection from leaking to ensure DP signal integrity.

304 (Traditional) & 305 Manifolds

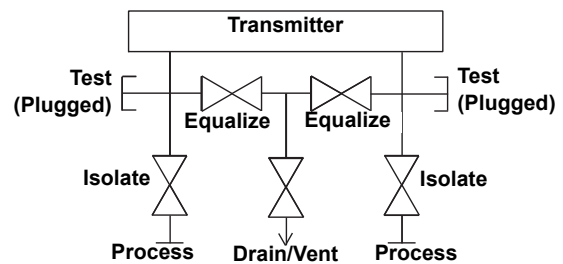

NOTE

Test/Vents receive plastic caps to protect threaded connections unless otherwise noted.

NOTE

Test (Plugged) connections receive 1/4-in. NPT plugs unless otherwise noted.

Specifications

Pressure and Temperature Ratings

FIGURE 1. 304 Conventional Manifolds - Pressure vs. Temperature

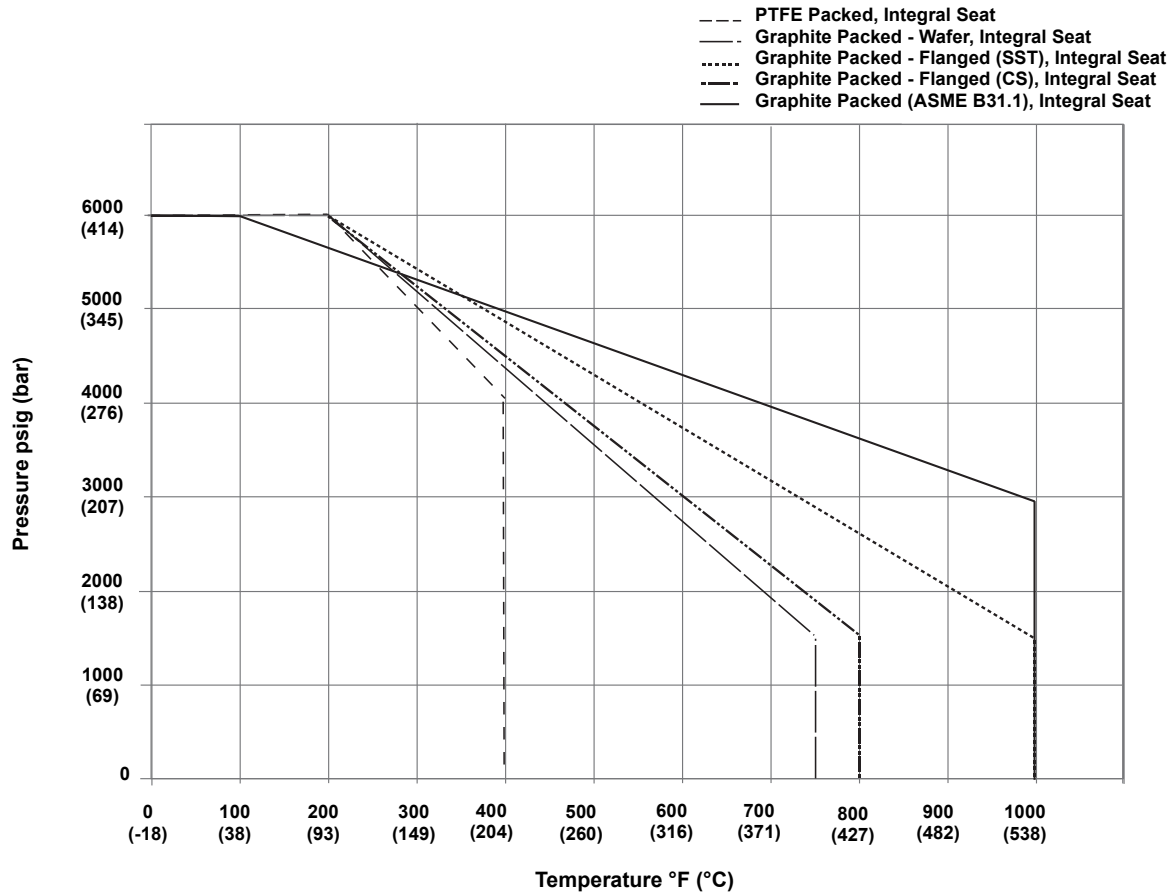

TABLE 1. 304 Conventional Manifolds - Pressure and Temperature Ratings

Packing	Seat	Pressure and Temperature Ratings
PTFE	Integral	6000 psi @ 200°F (414 bar @ 93°C) 4000 psi @ 400°F (276 bar @ 204°C)
Graphite - Wafer	Integral	6000 psi @ 200°F (414 bar @ 93°C) 1500 psi @ 750°F (103 bar @ 399°C)
Graphite - Flanged (SST)	Integral	6000 psi @ 200°F (414 bar @ 93°C) 1500 psi @ 1000°F (103 bar @ 538°C)
Graphite - Flanged (CS)	Integral	6000 psi @ 200°F (414 bar @ 93°C) 1500 psi @ 800°F (103 bar @ 427°C)
Graphite (ASME B31.1)	Integral	6000 psi @ 100°F (414 bar @ 38°C) 2915 psi @ 1000°F (201 bar @ 538°C)

FIGURE 2. 305 Integral Manifolds - Pressure vs. Temperature

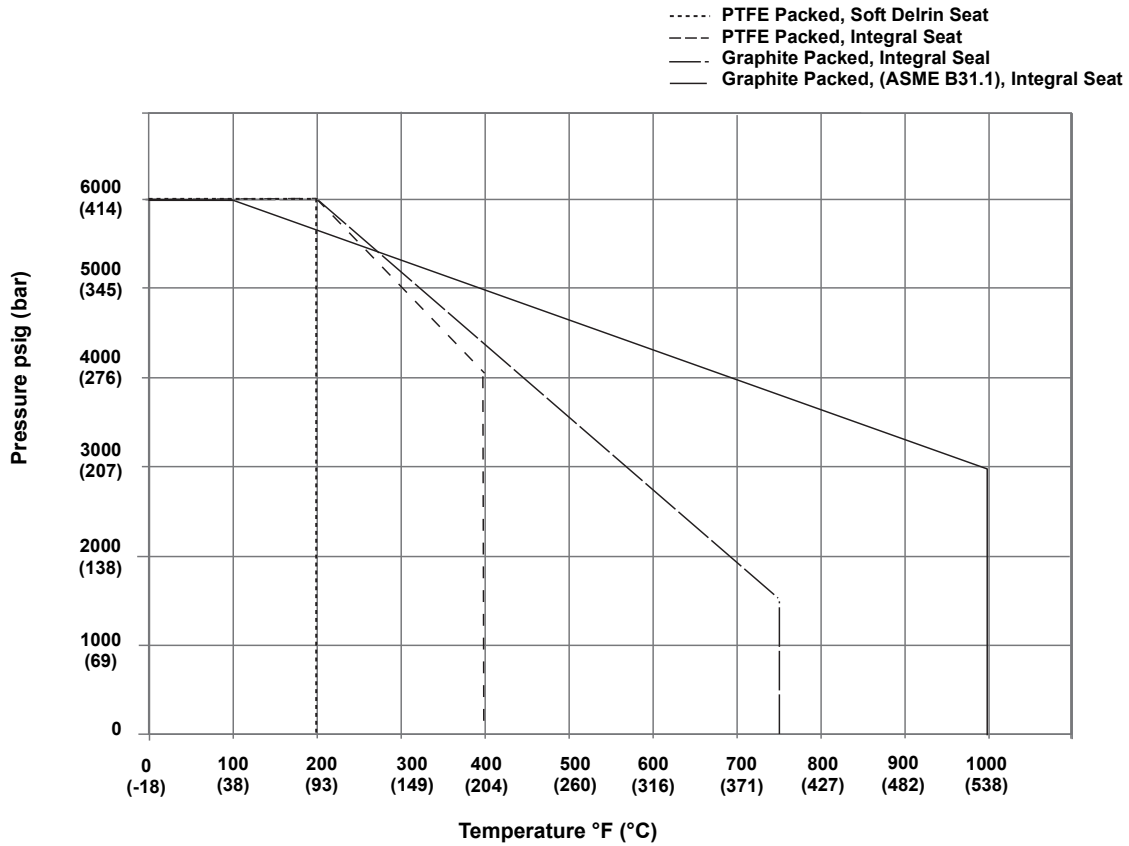

TABLE 2. 305 Integral Manifolds - Pressure and Temperature Ratings⁽¹⁾

Packing ⁽¹⁾	Seat	Pressure and Temperature Ratings
PTFE	Integral	6092 psi @ 200°F (420 bar @ 93°C) 4000 psi @ 400°F (276 bar @ 204°C)
PTFE	Soft Delrin	6092 psi @ 200°F (420 bar @ 93°C)
Graphite	Integral	6092 psi @ 200°F (420 bar @ 93°C) 1500 psi @ 750°F (103 bar @ 399°C)
Graphite (ASME B31.1)	Integral	6092 psi @ 100°F (420 bar @ 38°C) 2915 psi @ 1000°F (201 bar @ 538°C)

⁽¹⁾ Except option HK:
 PTFE, Integral seat: 2324 psi @ 200 °F (160 bar @ 93 °C), 1680 psi @ 400 °F (116 bar @ 204 °C)
 Graphite, Integral seat: 2324 psi @ 200 °F (160 bar @ 93 °C), 1125 psi @ 750 °F (78 bar @ 399 °C)

FIGURE 3. 306 integral Manifolds - Pressure vs. Temperature

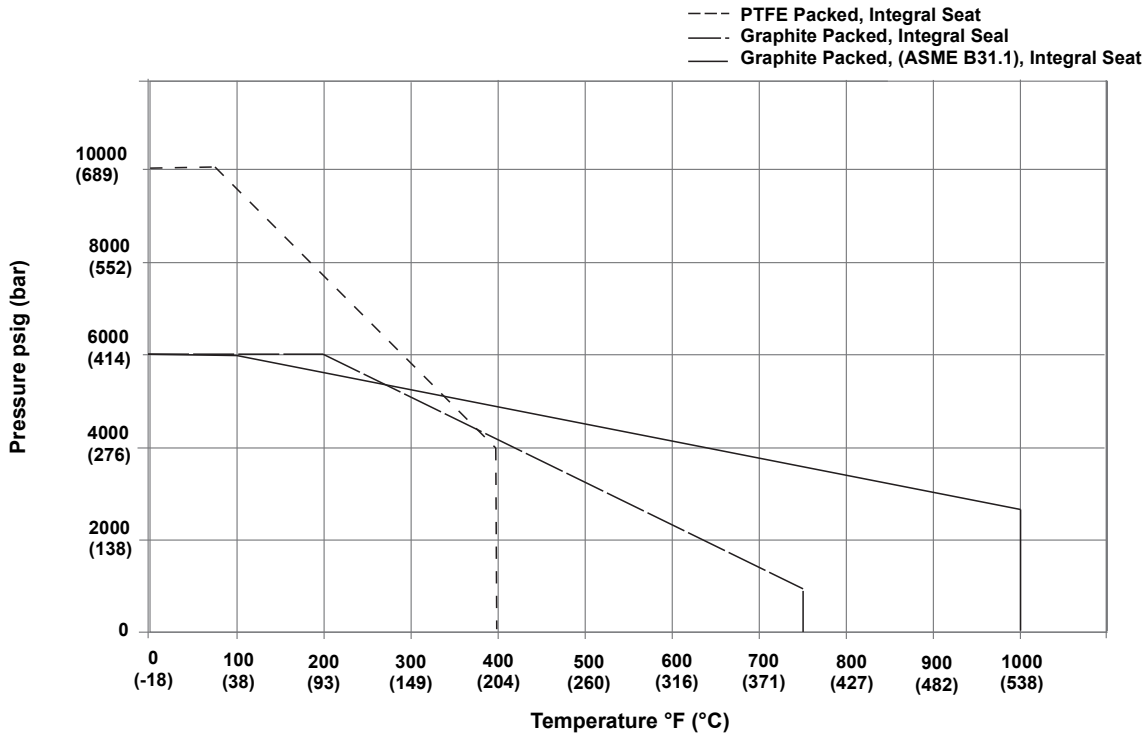

TABLE 3. 306 Integral manifolds - Pressure and Temperature Ratings

Packing	Seat	Pressure and Temperature Ratings
PTFE	Integral	10000 psi @ 85°F (689 bar @ 29°C) 4000 psi @ 400°F (276 bar @ 204°C)
Graphite	Integral	6000 psi @ 200°F (414 bar @ 93°C) 1500 psi @ 750°F (103 bar @ 399°C)
Graphite (ASME B31.1)	Integral	6000 psi @ 100°F (414 bar @ 38°C) 2915 psi @ 1000°F (201 bar @ 538°C)

Product Data Sheet

00813-0100-4733, Rev NA
April 2010

Rosemount Manifolds

Process Connections

TABLE 4. Process Connections

Model and Style	Connection
304 Flange by Pipe Flange by Flange Wafer	1/2 - 14 Female NPT 2 1/8-in. (54 mm) center-to-center connection (Process Adapters required) 1/2 - 14 Female NPT <u>Process Adapters</u> 1/2 - 14 Female NPT Flange Adapter 1/2-in. Ferrule Flange Adapter 12-mm Ferrule Flange Adapter
305 Coplanar Traditional	1/2 - 14 Female NPT 1/4 - 18 Female NPT (Process Adapters optional) <u>Optional Process Adapters</u> 1/2 - 14 Female NPT Flange Adapter 12 mm Ferrule Flange Adapter
306 Block-and-Bleed 2-Valve	1/2 - 14 Male NPT 1/2 - 14 NPT (Male or Female)

Instrument Connections

TABLE 5. Manifold - Transmitter Interface

Model	Connection
304	Mounted to traditional transmitter flange, 2 1/8-in. (54 mm) center-to-center connection per IEC 61518, Type B shut-off device (without SPIGOT)
305	Mounted directly to Coplanar sensor module of transmitter, 1.3-in. (287 mm) center-to-center process isolators
306	1/2 - 14 Male NPT

Test / Vent Connections

1/4-18 Female NPT

Manifold Bolts

Standard material is plated carbon steel per ASTM A449, Type 1

Alternative bolt materials offered through Option Codes

- L4 Austenitic 316 Stainless Steel Bolts
- L5 ASTM-A-193, Grade B7M Bolts
- L8 ASTM-A-193, Class 2, Grade B8M Bolts

Rosemount Manifolds

O-Rings

FIGURE 4. 304 Manifold O-Rings

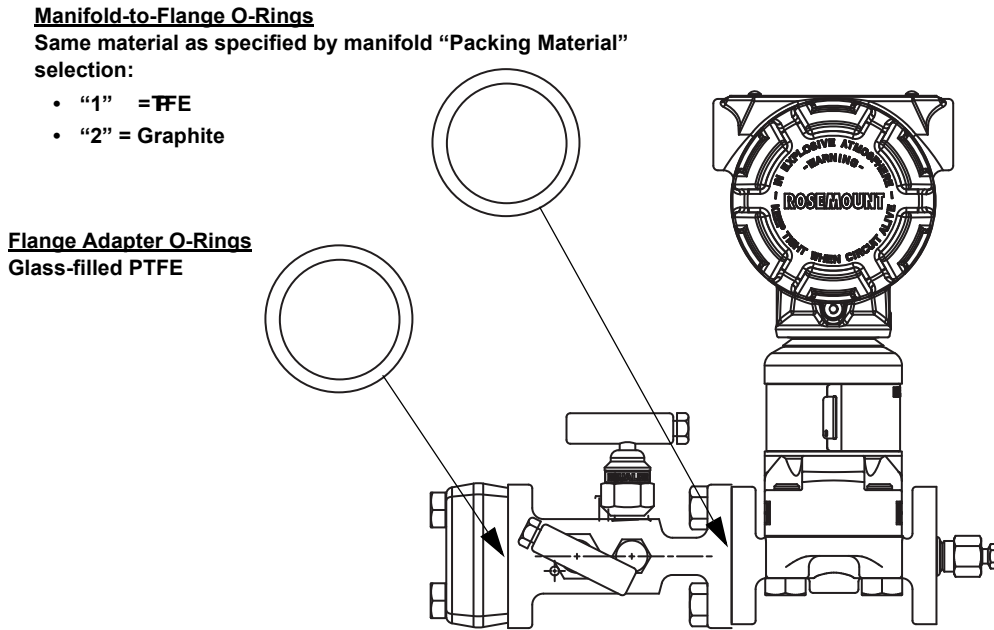
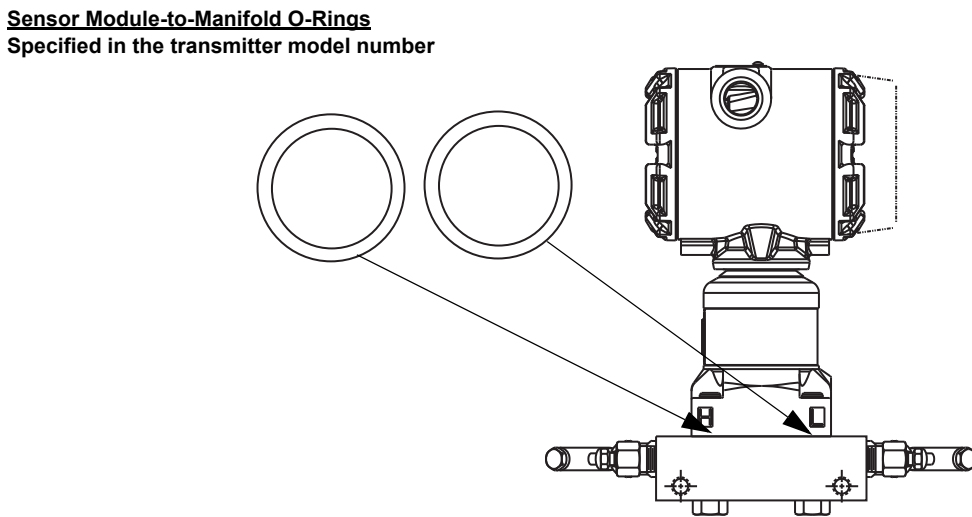

FIGURE 5. 305 Manifold O-Rings



Product Data Sheet

00813-0100-4733, Rev NA
 April 2010

Rosemount Manifolds

TABLE 6. 304 Conventional Manifolds - Process Wetted Materials of Construction

Component	SST	CS	SST with SG Option
Body	316 SST	CS	316 SST
Ball / Tip	316 SST /316Ti SST	316 SST	Alloy C-276
Stem	316 SST	316 SST	Alloy C-276
Packing	PTFE / Graphite	PTFE	PTFE / Graphite
Bonnet	316 SST	316 SST	316 SST
Pipe Plug	316 SST	CS	316 SST

TABLE 7. 305 Integral Manifolds - Process Wetted Materials of Construction

Component	SST	Alloy C-276	316 SST with SG option
Body	316 SST	Alloy C-276	316 SST
Ball / Tip	316 SST /316Ti SST	Alloy C-276	Alloy C-276
Stem	316 SST	Alloy C-276	Alloy C-276
Packing	PTFE / Graphite	PTFE / Graphite	PTFE / Graphite
Bonnet	316 SST	Alloy C-276	316 SST
Pipe Plug	316 SST	Alloy C-276	316 SST
Drain / Vent Valve	316 SST	Alloy C-276	Alloy C-276

TABLE 8. 306 Inline Manifolds - Process Wetted Materials of Construction

Component	SST	Alloy C-276	316 SST with SG option
Body	316 SST	Alloy C-276	316 SST
Ball / Tip	316 SST /316Ti SST	Alloy C-276	Alloy C-276
Stem	316 SST	Alloy C-276	Alloy C-276
Packing	PTFE / Graphite	PTFE / Graphite	PTFE / Graphite
Bonnet	316 SST	Alloy C-276	316 SST
Pipe Plug	316 SST	Alloy C-276	316 SST
Bleed Screw	316 SST / 316Ti SST	Alloy C-276	Alloy C-276

Materials of Construction - Typical

FIGURE 6. Typical Rosemount Manifold Valve

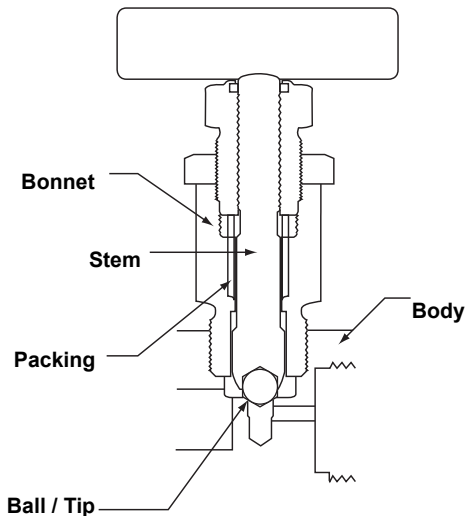

Estimated Weight

Model and Description	Weight
304	
2-valve traditional flange x NPT	5.0 lbs (2.3 kg)
2-valve traditional flange-x flange	5.5 lbs (2.5 kg)
3-valve traditional flange x NPT	5.2 lbs (2.4 kg)
3-valve traditional flange x flange	5.7 lbs (2.6 kg)
3-valve wafer flange x NPT	4.0 lbs (1.8 kg)
5-valve wafer flange x NPT	5.7 lbs (2.6 kg)
5-valve traditional flange x NPT	5.7 lbs (2.6 kg)
5-valve traditional flange x flange	5.7 lbs (2.6 kg)
305	
2-valve Coplanar	4.5 lbs (2.0 kg)
2-valve traditional	6.0 lbs (2.7 kg)
3-valve Coplanar	4.7 lbs (2.1 kg)
3-valve traditional	6.0 lbs (2.7 kg)
5-valve Coplanar	6.5 lbs (3.0 kg)
306	
Block-and-Bleed	1.1 lbs (0.5 kg)
2-valve	2.5 lbs (1.1 kg)

Dimensional Drawings

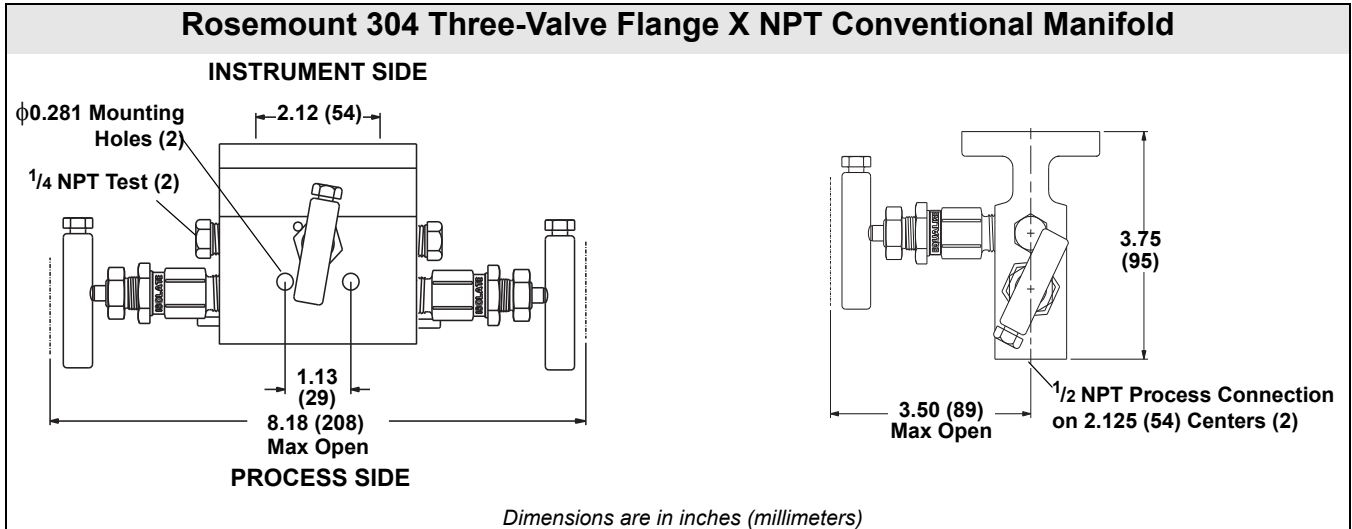
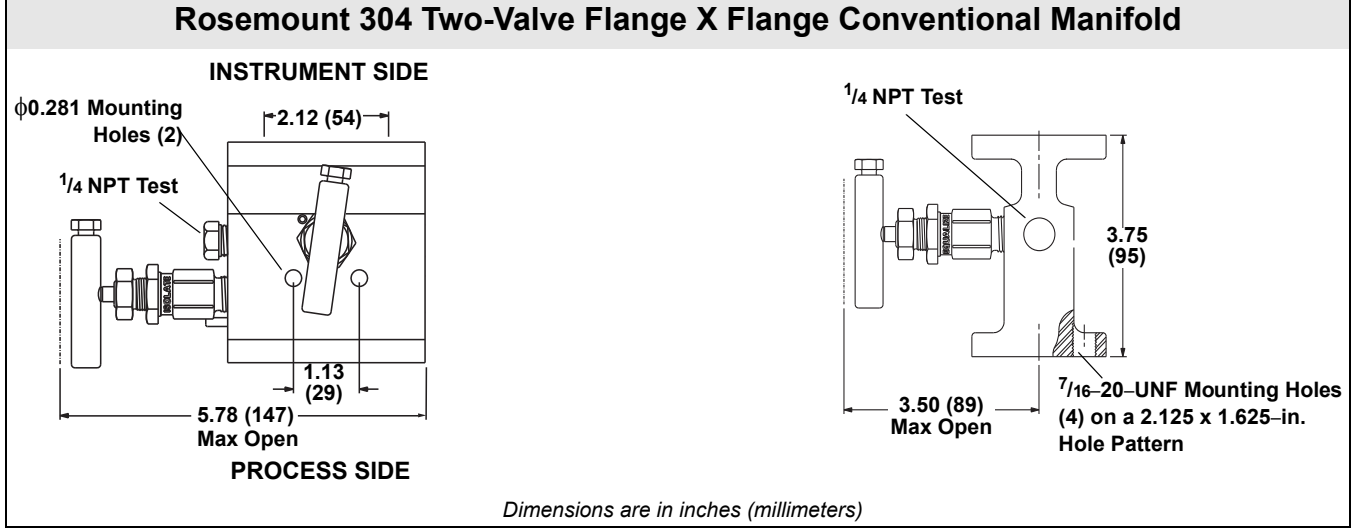
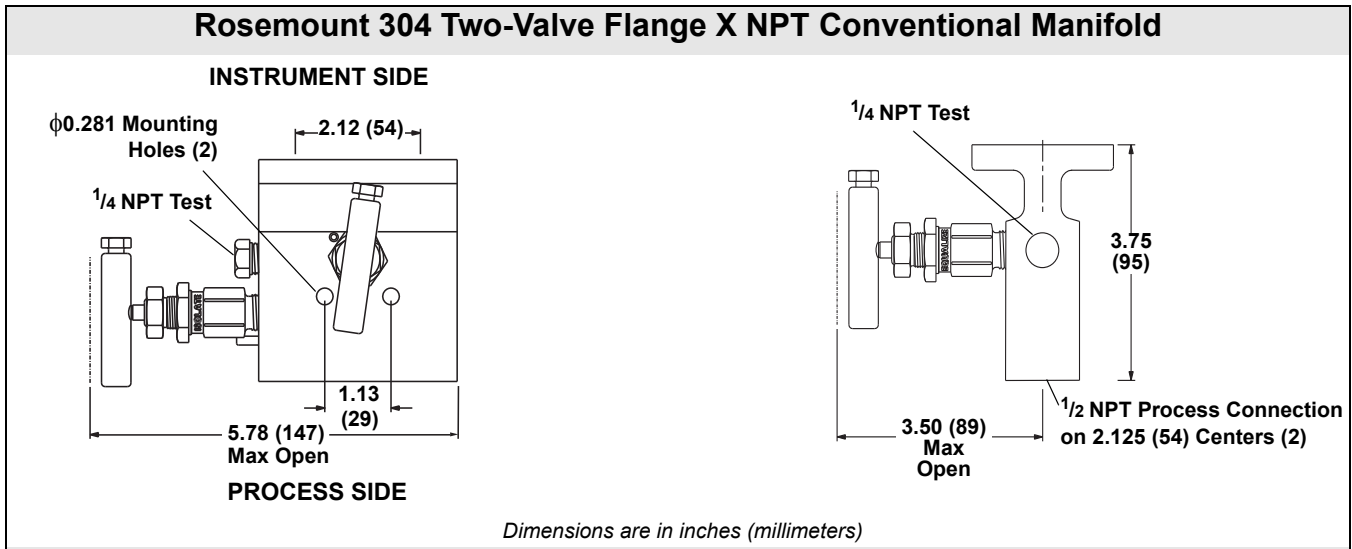

Rosemount 304 Three-Valve Flange X Flange Conventional Manifold

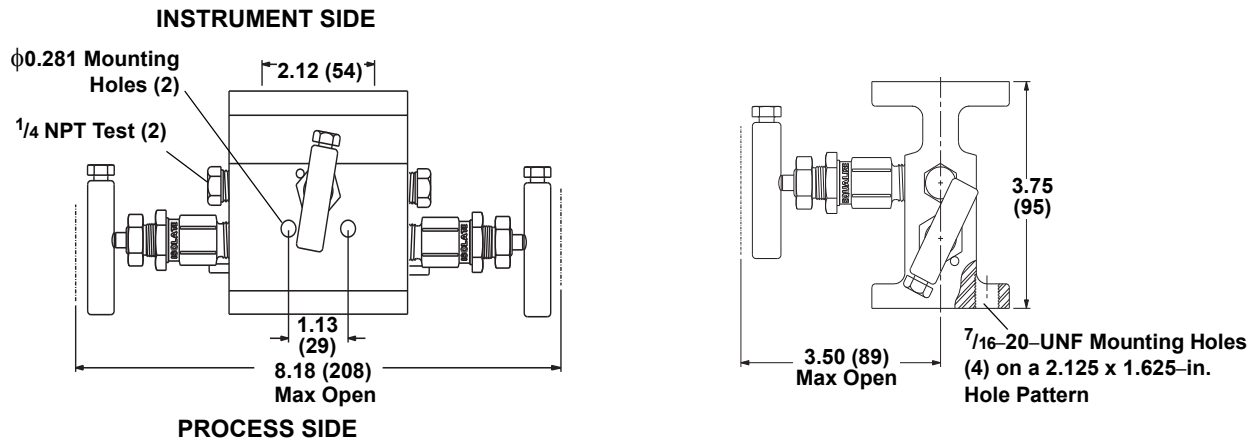

Dimensions are in inches (millimeters)

Rosemount 304 Natural Gas Five-Valve Flange X NPT Conventional Manifold

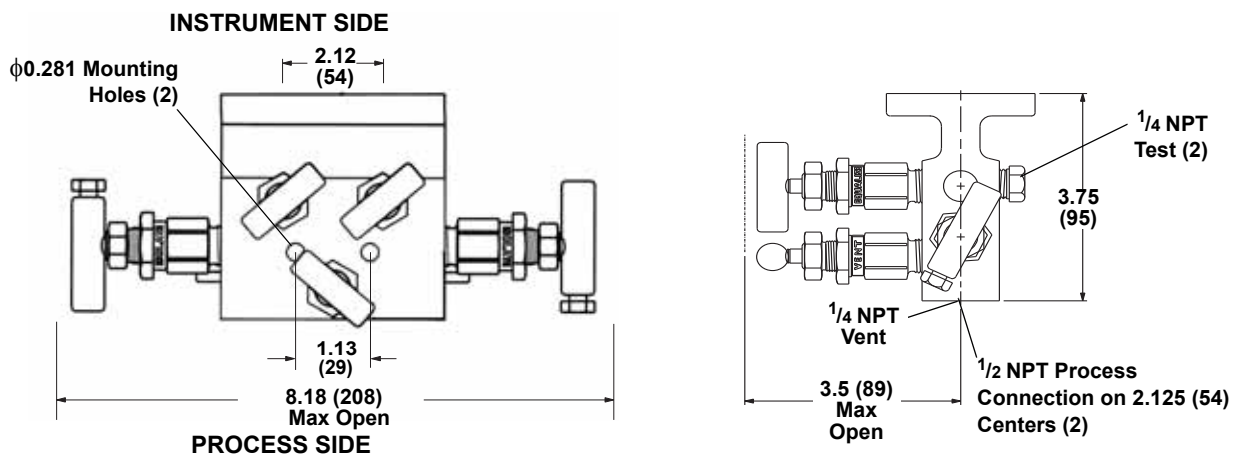

Dimensions are in inches (millimeters)

Rosemount 304 Natural Gas Five-Valve Flange X Flange Conventional Manifold

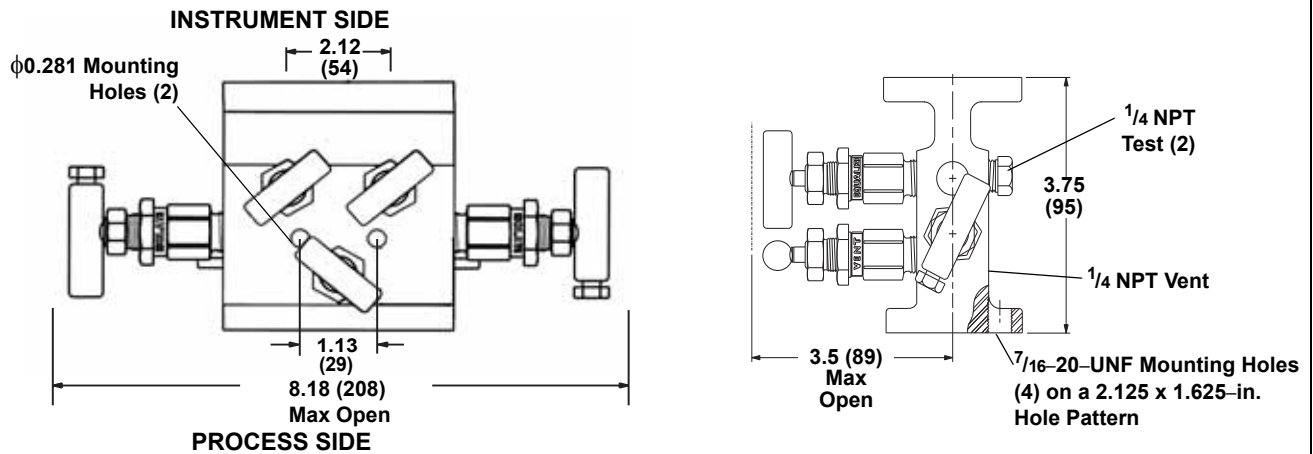

Dimensions are in inches (millimeters)

Rosemount Manifolds

Rosemount 304 Three-Valve Wafer Manifold

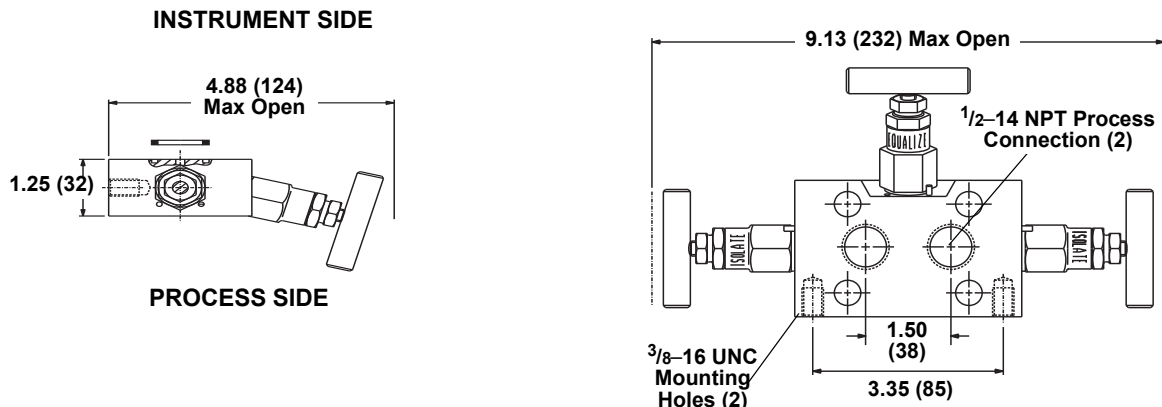

Dimensions are in inches (millimeters)

Rosemount 304 Five-Valve Wafer Manifold

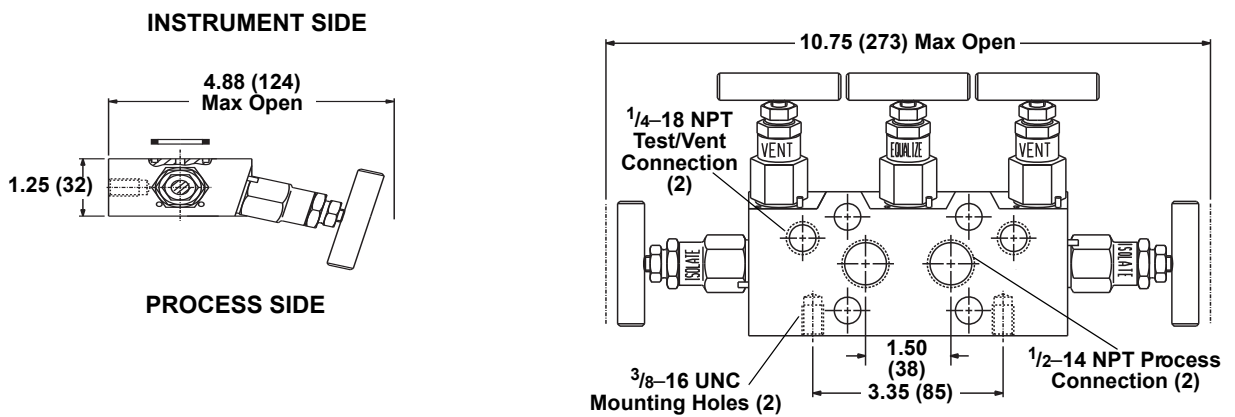

Dimensions are in inches (millimeters)

Rosemount 305R Two-Valve Coplanar Style Manifold

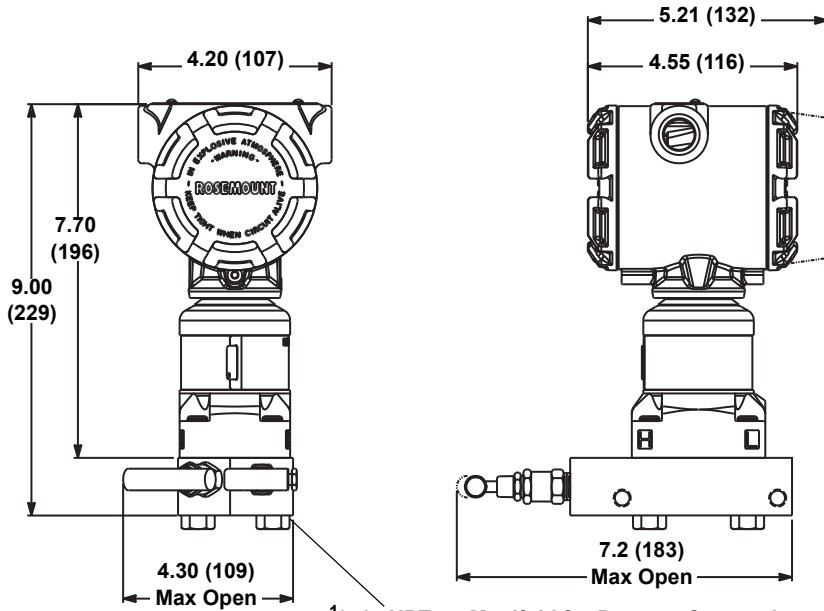

¹/₂-14 NPT on Manifold for Process Connection
¹/₄-18 NPT for test/vent connection.

Dimensions are in inches (millimeters)

Rosemount 305R Three-Valve Coplanar Style Manifolds

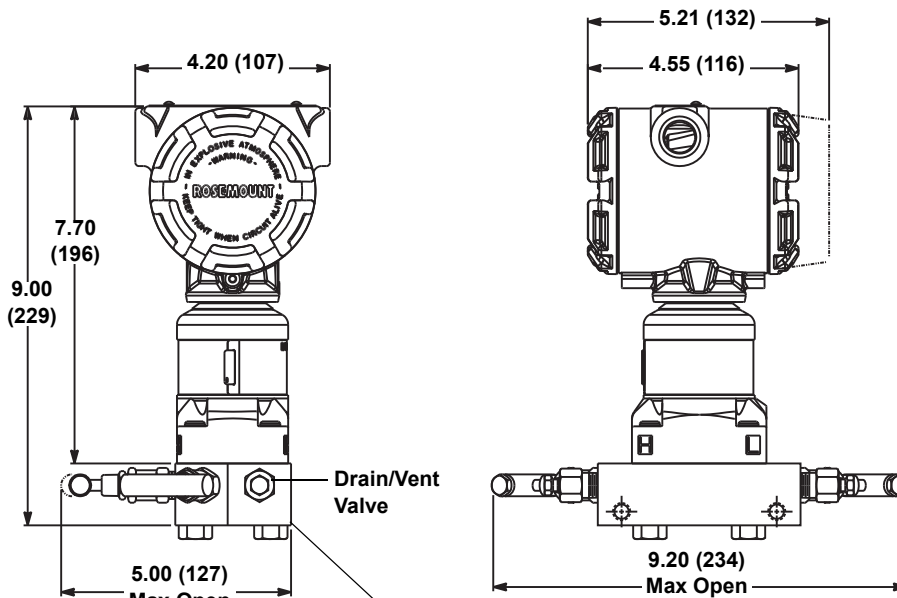

¹/₂-14 NPT on Manifold for Process Connections, 2.125 inch center-to-center

Dimensions are in inches (millimeters)

Rosemount 305R Five-Valve Coplanar Style Manifold

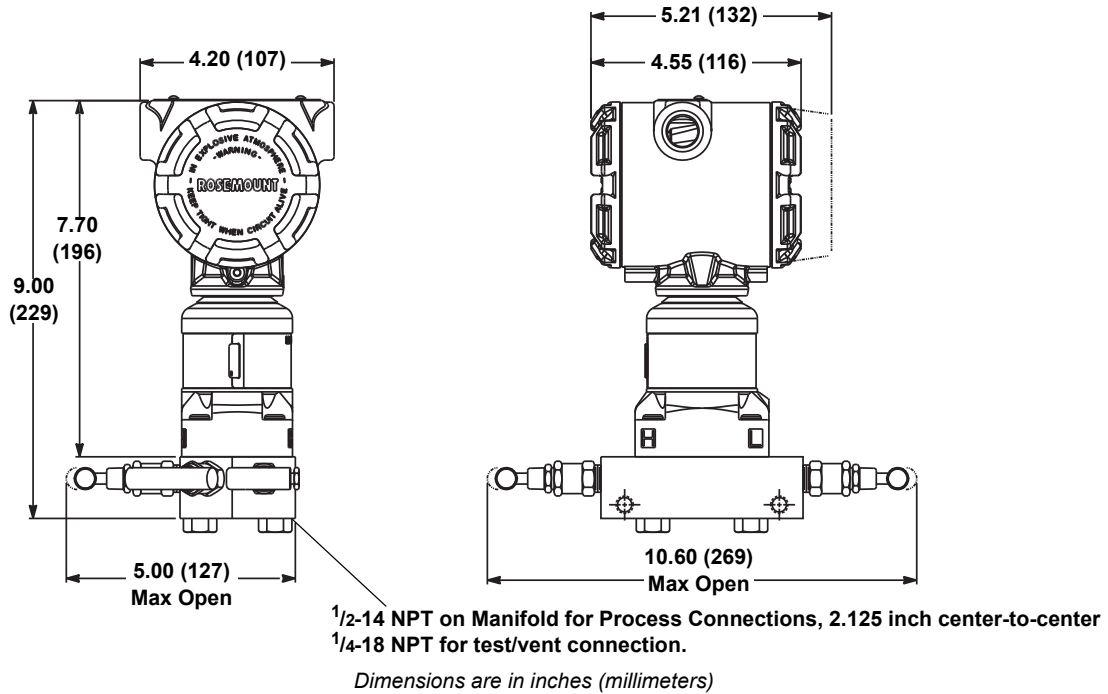

Rosemount 305RT Two-Valve Traditional Style Manifold

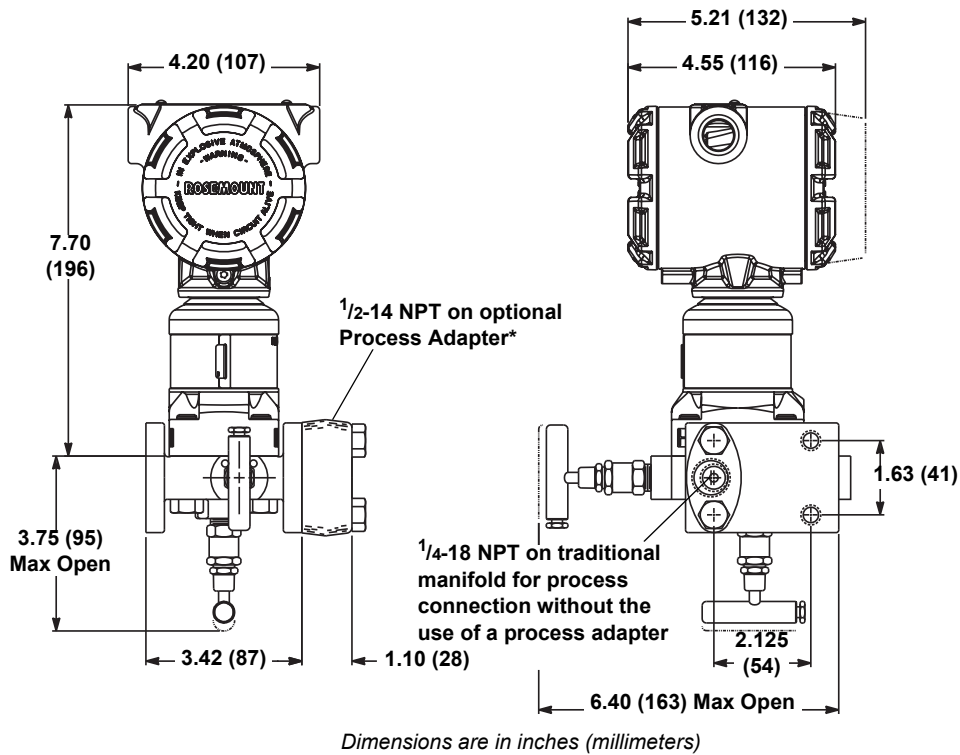

Rosemount 305RT Three-Valve Traditional Style Manifold

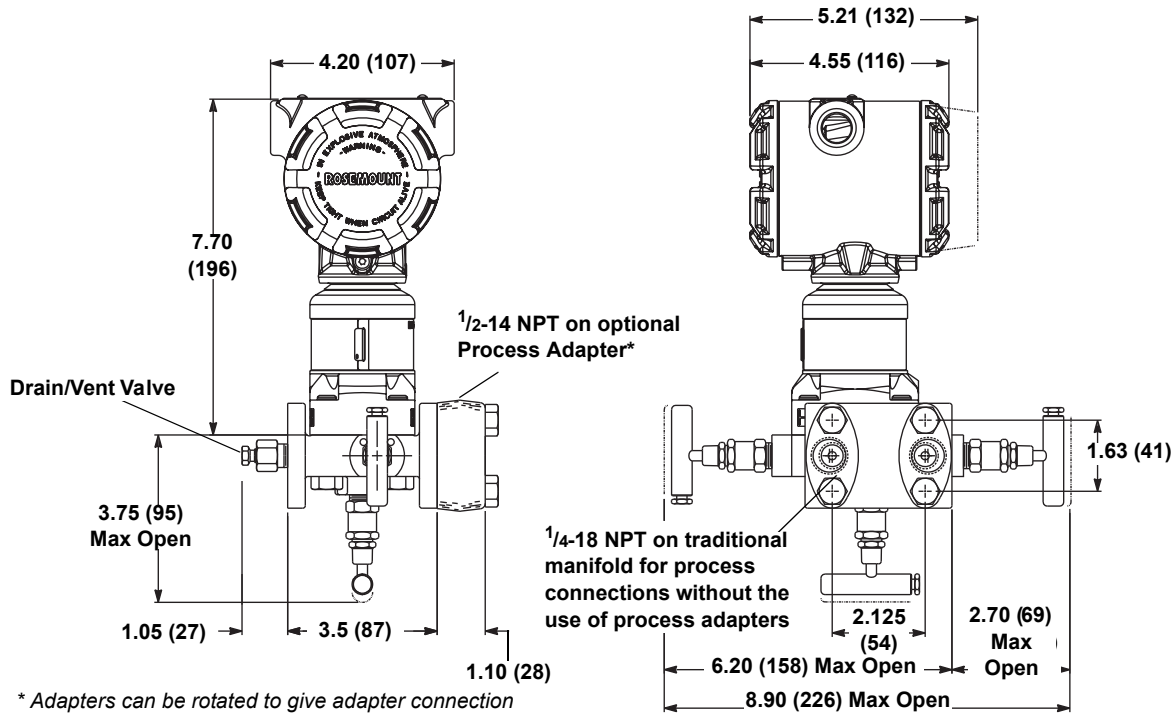

* Adapters can be rotated to give adapter connection centers of 2.0 (51), 2.125 (54), or 2.25 (57).

Dimensions are in inches (millimeters)

Rosemount 305RM Two-Valve Traditional Style Manifold

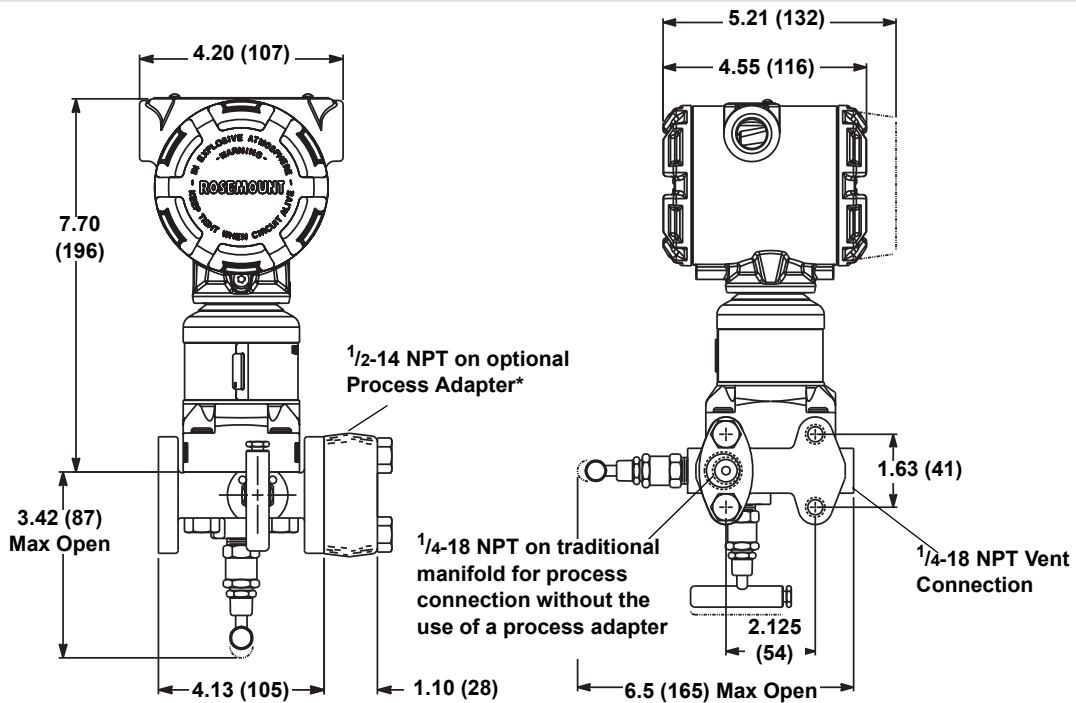

Dimensions are in inches (millimeters)

Rosemount 305RM Three-Valve Traditional Style Manifold

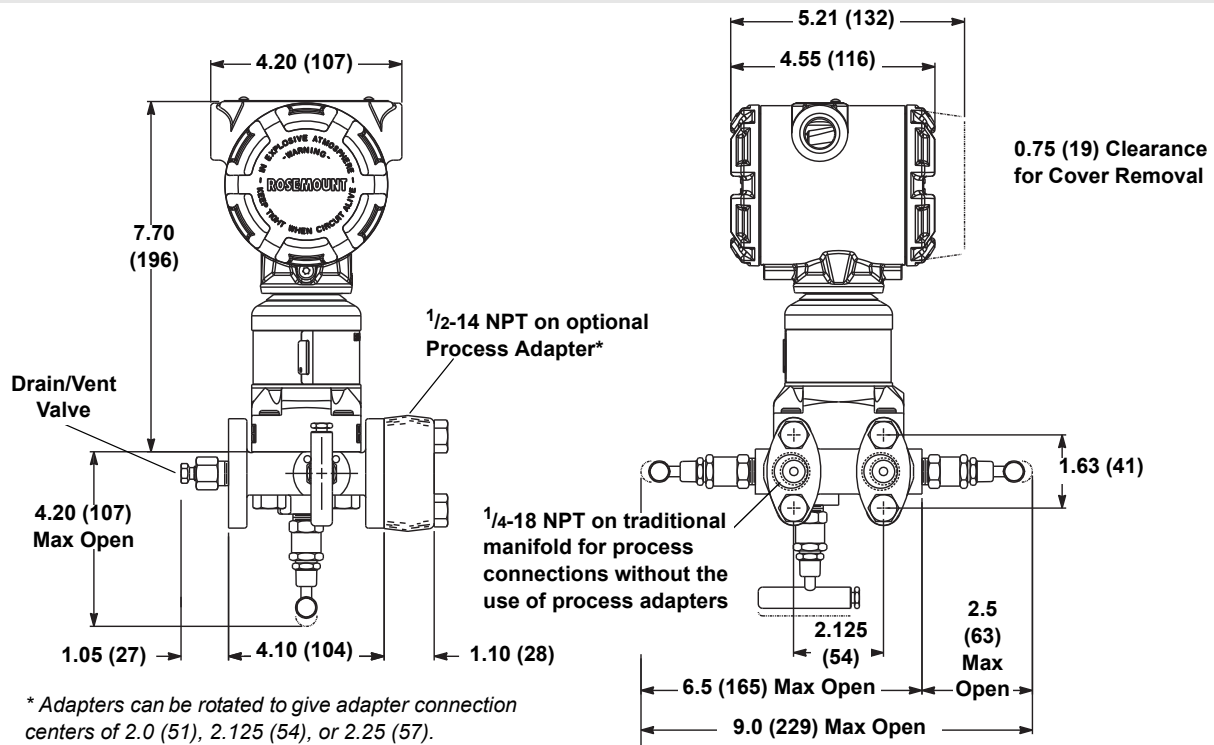

* Adapters can be rotated to give adapter connection centers of 2.0 (51), 2.125 (54), or 2.25 (57).

Dimensions are in inches (millimeters)

Rosemount 305RM Five-Valve Traditional Style Manifold

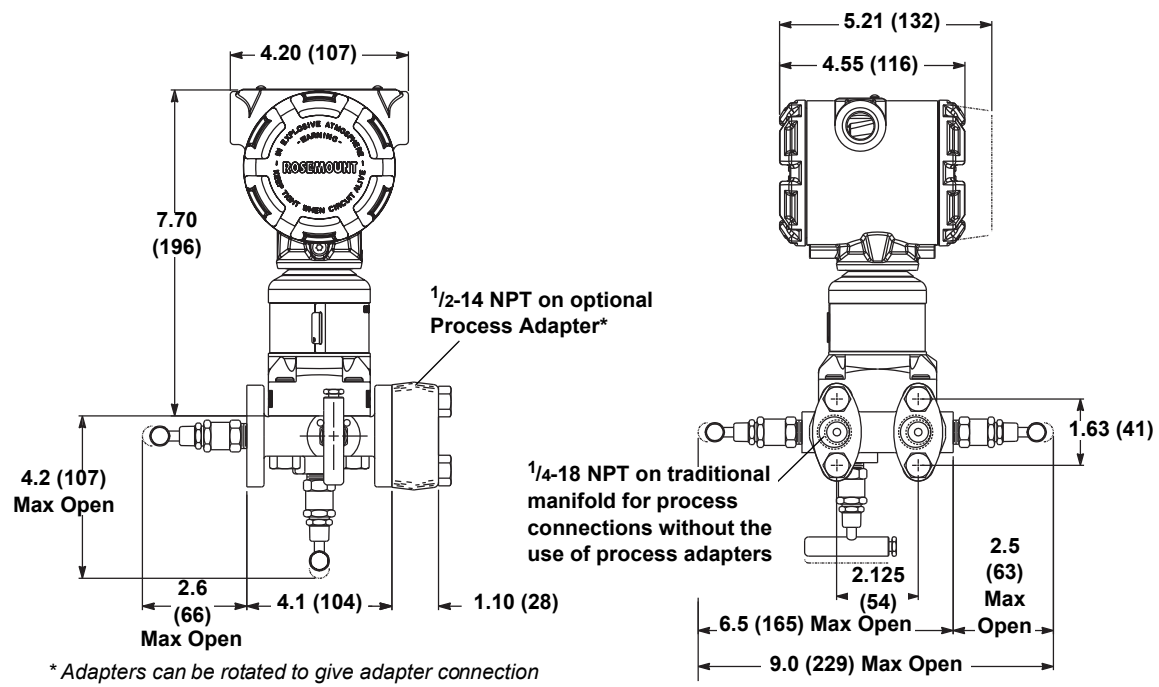

* Adapters can be rotated to give adapter connection centers of 2.0 (51), 2.125 (54), or 2.25 (57).

Dimensions are in inches (millimeters)

Rosemount 306R Pressure Style Manifold (3051S_T Shown)

BLOCK AND BLEED STYLE

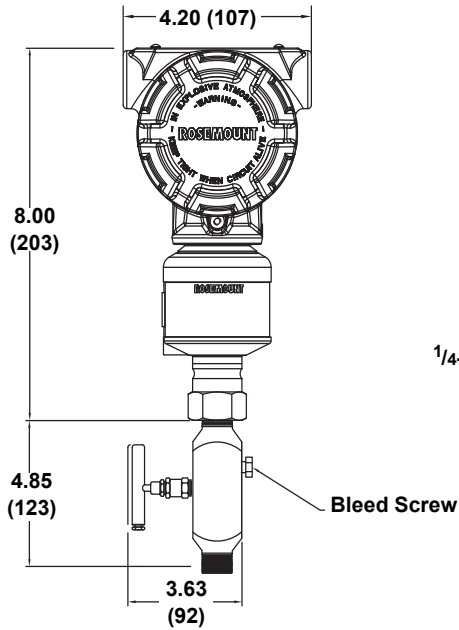

TWO-VALVE STYLE

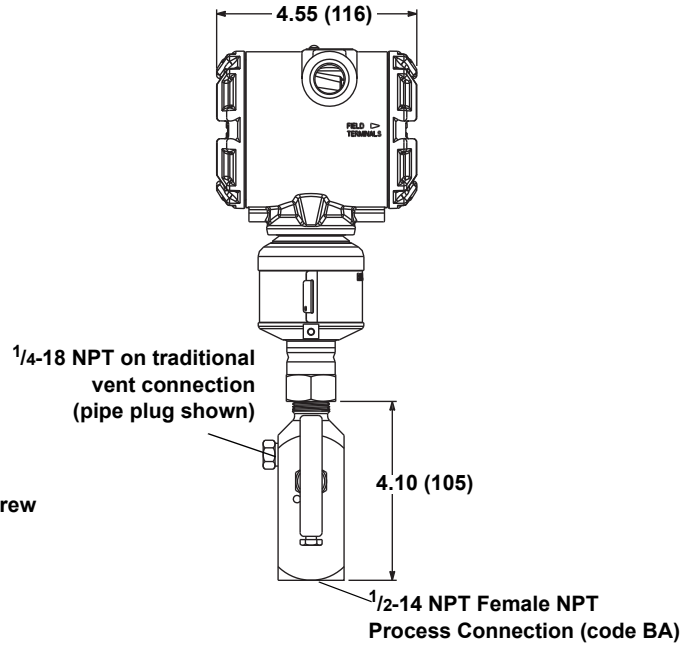

Manifold valve orientation may vary with respect to transmitter mounting holes.

Dimensions are in inches (millimeters)

Rosemount Manifolds

Installations for Rosemount 3051T and 3051S_T Transmitters for 2-in. Pipe Mounting

ROSEMOUNT 3051T

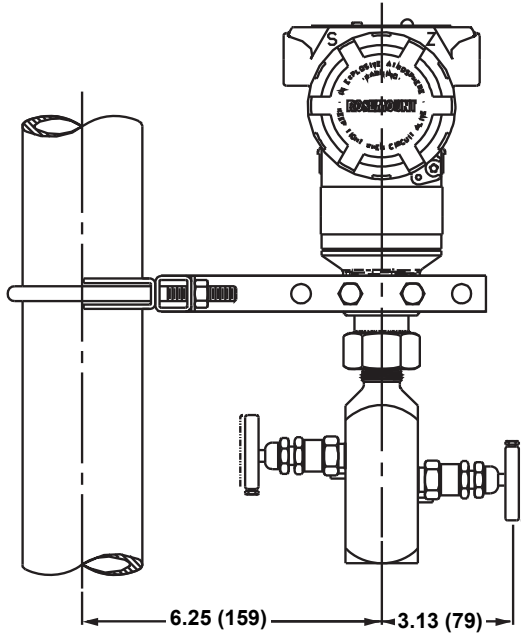

ROSEMOUNT 3051S_T

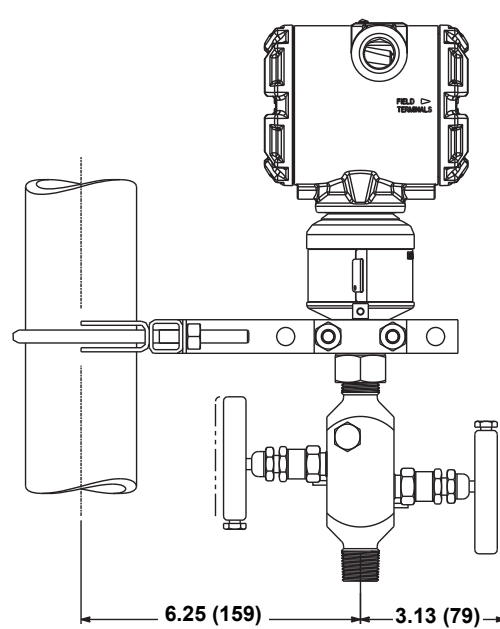

NOTE: Dimensions are in inches (millimeters).

Manifold valve orientation may vary with respect to transmitter mounting holes.

Dimensions are in inches (millimeters)

Coplanar Manifold with Optional Bracket for 2-in. Pipe Mounting

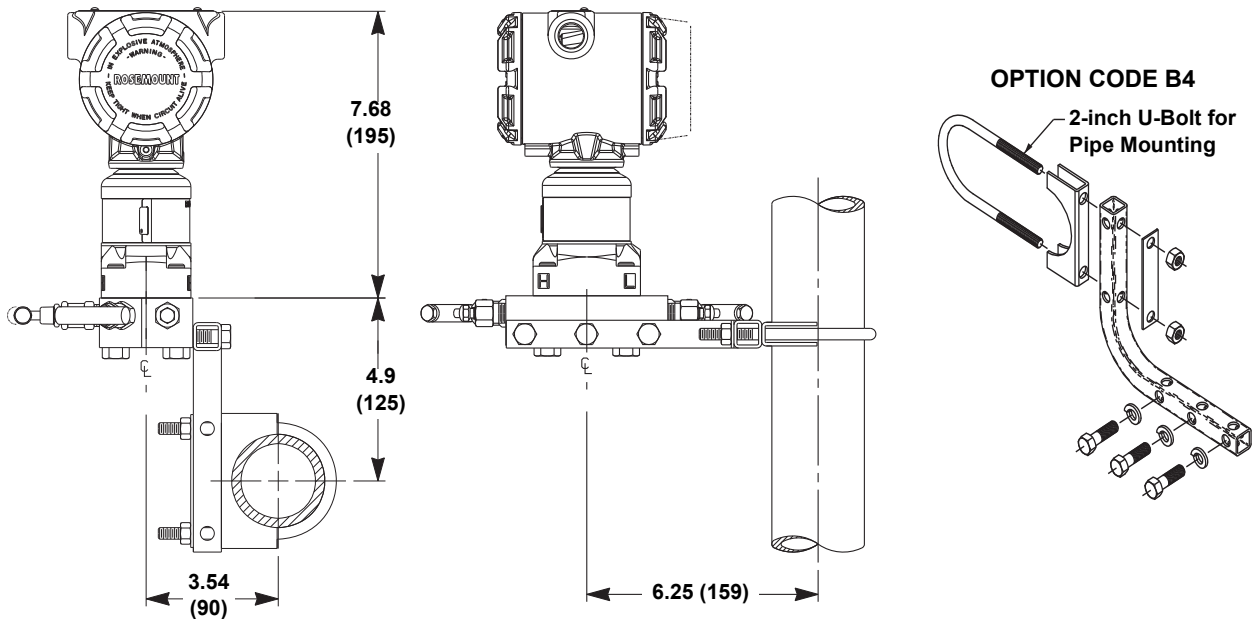

Dimensions are in inches (millimeters)

Traditional Manifold with Optional Brackets for 2-in. Pipe Mounting

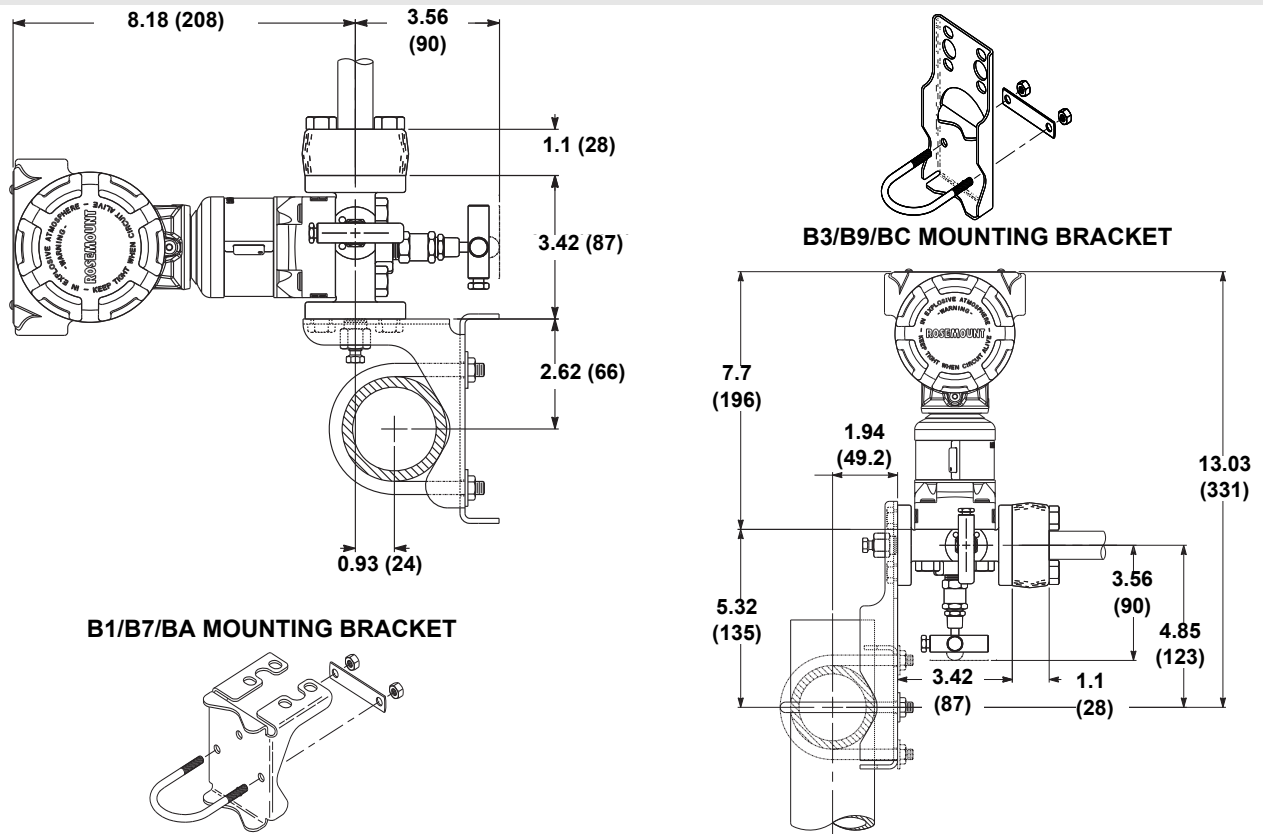

Dimensions are in inches (millimeters)

VS/VC Heavy Duty Manifold Mounting Bracket

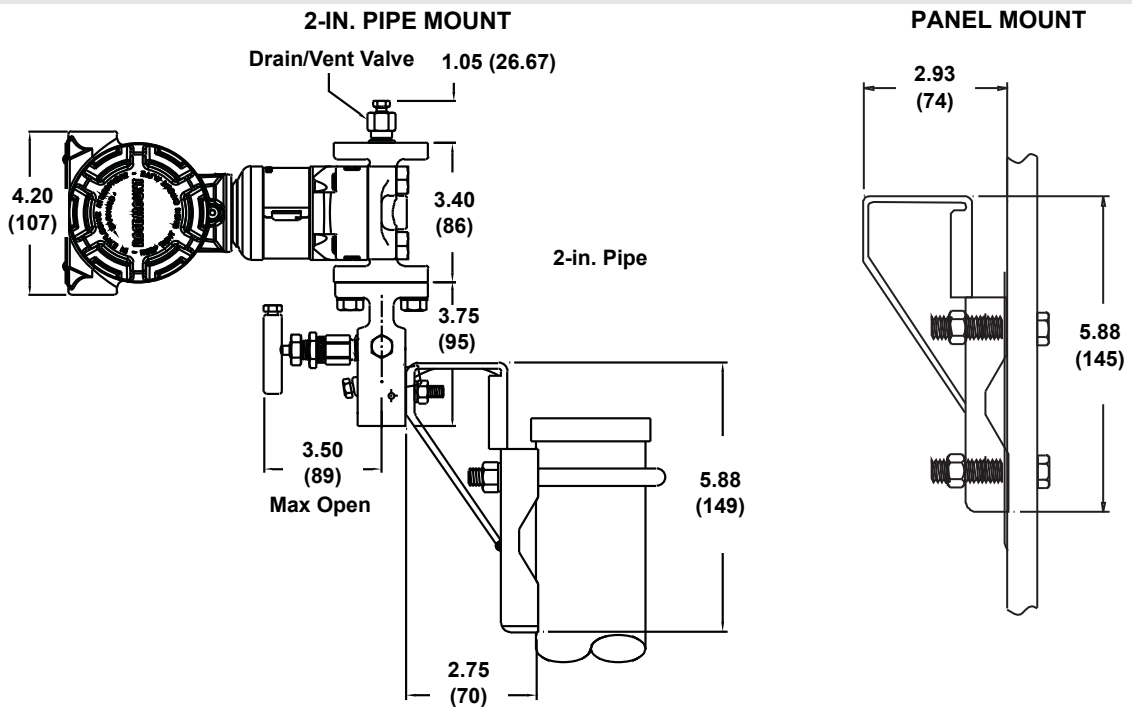

Dimensions are in inches (millimeters)

Rosemount Manifolds

Ordering Information

Rosemount Manifolds can be ordered as a stand-alone product or as an integrated assembly that is attached to a transmitter.

Stand-Alone Manifold:

1. Reference the “Rosemount Manifolds Selection Guide” (see page 3) for assistance on choosing the type of manifold needed.
2. Specify a completed model number by referencing the applicable ordering table for the selected manifold type:
 - a. Rosemount 304 Conventional Manifold, see page 23.
 - b. Rosemount 305 Integral Manifold, see page 25.
 - c. Rosemount 306 Inline Manifold, see page 27.

Transmitter / Manifold Assembly:

1. Specify a completed Rosemount transmitter model number by referencing the applicable product data sheet.
2. Specify a completed manifold model number by referencing the applicable ordering table for the selected manifold type:
 - a. Rosemount 304 Conventional Manifold, see page 23.
 - b. Rosemount 305 Integral Manifold, see page 25.
 - c. Rosemount 306 Inline Manifold, see page 27.
3. Verify the transmitter model number contains the correct “Process Connection” code or “Manifold Option” code for the desired transmitter manifold assembly (see Table 9).

TABLE 9. Ordering Codes for a Transmitter / Manifold Assembly

Transmitter	Manifold	Process Connection Code	“Manifold” Option Code
3051S	304	A12	–
	305	A11	–
	306	A11	–
3051/2051/3095	304	–	S6
	305	–	S5
	306	–	S5
1151	304	S6	–
	305	–	–
	306	–	–
2088	304	–	–
	305	–	–
	306	–	S5

Rosemount 304 Conventional Manifolds

TABLE 10. Rosemount 304 Conventional Manifold Ordering Information

★ The Standard offering represents the most common options. The starred options (★) should be selected for best delivery.
The Expanded offering is subject to additional delivery lead time.

Model	Product Description				
0304	Conventional Manifold				
Manufacturer					
Standard					Standard
R	Rosemount Inc.				★
Manifold Style					
Standard					Standard
T	Traditional (Flange x Flange or Flange x NPT)				★
Expanded					
W ⁽¹⁾	Wafer				
Manifold Type					
Standard					Standard
2 ⁽²⁾	2-valve				★
3	3-valve				★
5 ⁽³⁾	5-valve				★
6 ⁽²⁾	5-valve Natural Gas Metering Pattern				★
Expanded					
7 ⁽²⁾⁽⁴⁾	2-valve (per ASME B31.1 [ANSI] Power and Piping Code)				
8 ⁽²⁾⁽⁴⁾	3-valve (per ASME B31.1 [ANSI] Power and Piping Code)				
	Body	Bonnet	Stem	Tip	
Standard					Standard
2	316 SST	316 SST	316 SST	316 SST	★
5	CS	316 SST	316 SST	316 SST	★
Process Connection Style					
Standard					Standard
B	¹ / ₂ -14 NPT				★
F ⁽²⁾	Flanged				★
Packing Material					
Standard					Standard
1	PTFE				★
Expanded					
2 ⁽¹⁾	Graphite-based				
Transmitter Type					
Standard					Standard
1	For assembly to 2051/3051 Traditional Flange				★
2	For assembly to 2051/3051/3095 DIN Compliant Traditional Flange				★
3	For assembly to 2051/3051/3095 Coplanar Flange				★
OPTIONS					
Mounting Brackets					
Standard					Standard
VC ⁽²⁾	Manifold Heavy Duty Mounting Bracket, CS for Traditional Style				★
VS ⁽²⁾	Manifold Heavy Duty Mounting Bracket, SST for Traditional Style				★
B4	Manifold SST Mounting Bracket for 2-in. pipe mount with series 300 SST bolts for wafer style				★
Adapters					
Standard					Standard
DF ⁽⁵⁾	¹ / ₂ -14 NPT Female Flange Adapter				★
DT ⁽⁵⁾	¹ / ₂ -in. ferrule flange adapter				★
DQ ⁽⁵⁾	12 mm ferrule flange adapter				★

Rosemount Manifolds

TABLE 10. Rosemount 304 Conventional Manifold Ordering Information

★ The Standard offering represents the most common options. The starred options (★) should be selected for best delivery. The Expanded offering is subject to additional delivery lead time.

Bolts		
Standard		Standard
L4 ⁽⁶⁾	Austenitic 316 SST Bolts	★
L5	ASTM A 193, Grade B7M Bolts	★
L8	ASTM A 193, Class 2, Grade B8M Bolts	★
Material Recommendations for NACE		
Standard		Standard
SG ⁽¹⁾⁽⁷⁾	Sour Gas (Meets NACE MR 0175 / ISO 15156, MR 0103)	★
Cleanings		
Expanded		
P2 ⁽⁸⁾	Cleaning for special service	
Heater Block Kits		
Standard		Standard
SB	Steam block kit, ¼-in. NPT connection	★
Typical Model Number: _ 0304_R_T_3_2_B_1_1_VS		

(1) Only allowed with Material of Construction code 2.

(2) Not available with Wafer Manifold Style code W.

(3) Not available with Traditional Manifold Style code T.

(4) Only available with 316 SST materials of construction code 2 and graphite based packing code 2.

(5) Only allowed with both Manifold Style code T and Process Connection code F. Not allowed with Graphite-based Packing Code 2.

(6) Not available with Manifold Type codes 7, 8.

(7) Materials of construction comply with recommendations per NACE MR 0175 / ISO 1516 for sour oil field production environments. Environmental limits apply to certain materials. Consult latest standard for details. Selected materials also conform to NACE MR 0103 for sour refining environments.

(8) Not available with Graphite-Based Packing Material code 2.

Rosemount 305 Integral Manifolds

TABLE 11. Rosemount 305 Integral Manifold Ordering Information

★ The Standard offering represents the most common options. The starred options (★) should be selected for best delivery.
The Expanded offering is subject to additional delivery lead time.

Model		Product Description			
0305		Integral Manifold			
Manufacturer					
Standard					Standard
R	Rosemount				★
Manifold Style					
Standard					Standard
C	Coplanar				★
T	Traditional				★
M	Traditional (Rosemount 3095-compatible; DIN-compliant flange)				★
Manifold Type					
Standard					Standard
2	2-valve				★
3	3-valve				★
5 ⁽¹⁾	5-valve				★
6 ⁽²⁾	5-valve Natural Gas Metering Pattern				★
Expanded					
7 ⁽²⁾⁽³⁾	2-valve (per ASME B31.1 [ANSI] Power and Piping Code)				
8 ⁽²⁾⁽³⁾	3-valve (per ASME B31.1 [ANSI] Power and Piping Code)				
9 ⁽²⁾⁽³⁾	5-valve (per ASME B31.1 [ANSI] Power and Piping Code)				
	Body	Bonnet	Stem and Tip / Ball		
Standard					Standard
2	316 SST	316 SST	316 SST		★
Expanded					
3 ⁽⁴⁾⁽⁵⁾	Alloy C-276	Alloy C-276	Alloy C-276		
4	Alloy 400	Alloy 400	Alloy 400 / K-500		
Process Connection Style					
Standard					Standard
A	1/4–18 NPT female				★
B	1/2–14 NPT female				★
Packing Material					
Standard					Standard
1	PTFE				★
Expanded					
2 ⁽⁶⁾	Graphite-based				
Valve Seat					
Standard					Standard
1	Integral				★
5	Soft delrin (only available with natural gas metering pattern)				★
OPTIONS					
Mounting Brackets					
Standard					Standard
B1	Bracket for 2-in. pipe mounting, CS bolts				★
B3 ⁽⁷⁾	Flat bracket for 2-in. pipe mounting, CS bolts				★
B4	SST Mounting Bracket for 2-in. pipe mounting, CS bolts				★
B7	B1 bracket with series 300 SST bolts				★
B9 ⁽⁷⁾	B3 bracket with series 300 SST bolts				★
BA	SST B1 bracket with series 300 SST bolts				★
BC ⁽⁷⁾	SST B3 bracket with series 300 SST bolts				★

Rosemount Manifolds

TABLE 11. Rosemount 305 Integral Manifold Ordering Information

★ The Standard offering represents the most common options. The starred options (★) should be selected for best delivery.
The Expanded offering is subject to additional delivery lead time.

Bolts		
Standard		Standard
L4 ⁽⁸⁾	Austenitic 316 SST bolts	★
L5	ASTM-A-193-B7M bolts	★
L8	ASTM-A-193, Class 2, Grade B8M bolts	★
Cleanings		
Standard		Standard
P2 ⁽⁹⁾	Cleaning for special services	★
Material Recommendations for NACE		
Standard		Standard
SG ⁽⁵⁾⁽¹⁰⁾	Sour Gas (Meets NACE MR 0175 / ISO 15156, MR 0103)	★
Adapters		
Standard		Standard
DF ⁽¹¹⁾	¹ / ₂ -14 NPT female flange adapter	★
Expanded		
DQ ⁽¹¹⁾	12 mm ferrule flange adapter	
Process Flange Bolting Connection		
Standard		Standard
HK ⁽¹²⁾	10mm (M10) process flange bolting connection	★
HL ⁽¹²⁾	12mm (M12) process flange bolting connection	★
Typical Coplanar Integral Manifold Model Number: 305RC32B11B4		
Typical Transmitter Model Number: 3051CD2A02A1AS5		

(1) Not available with traditional manifold style T.

(2) Only available with Coplanar manifold style code C.

(3) Only available with 316 SST materials of construction code 2 and graphite based backing code 2.

(4) Not available with traditional manifold Style code M.

(5) Materials of Construction comply with recommendations per NACE MR 0175/ISO 15156 for sour oil field production environments. Environmental limits apply to certain materials. Consult latest standard for details. Selected materials also conform to NACE MR0103 for sour refining environments.

(6) Includes graphite tape on drain/vent valves and plugs.

(7) Not compatible with the Rosemount 3095 transmitter.

(8) Not available with ASME B31.1 manifold type codes 7, 8, and 9.

(9) Not available with Graphite-Based Packing Material code 2.

(10) Only available with 316 SST Materials of Construction Code 2: 316 SST body and bonnets; Alloy C-276 stems, tip/balls, and drain/vents.

(11) Only allowed with Manifold Style code T. Not allowed with Graphite-Based Packing code 2.

(12) Only available with traditional manifold style code M.

Rosemount 306 Inline Manifolds

TABLE 12. Rosemount 306 Inline Pressure Manifold Ordering Information

★ The Standard offering represents the most common options. The starred options (★) should be selected for best delivery.
The Expanded offering is subject to additional delivery lead time.

Model	Product Description			
0306	Pressure Manifold			
Manufacturer				
Standard				Standard
R	Rosemount Inc.			★
Manifold Style				
Standard				Standard
T	Threaded			★
Manifold Type				
Standard				Standard
1	Block and bleed			★
2	2-valve			★
Expanded				
3 ⁽¹⁾	2-valve (per ASME B31.1 Power Piping Code)			
	Body	Bonnet	Stem and Tip / Ball	
Standard				Standard
2	316 SST	316 SST	316 SST	★
Expanded				
3 ⁽²⁾⁽³⁾	Alloy C-276	Alloy C-276	Alloy C-276	
Process Connection				
Standard				Standard
AA	1/2-14 male NPT			★
BA ⁽²⁾	1/2-14 female NPT			★
Packing Material				
Standard				Standard
1	PTFE			★
Expanded				
2 ⁽⁴⁾	Graphite-based			
Valve Seat				
Standard				Standard
1	Integral			★
OPTIONS				
Cleanings				
Expanded				
P2 ⁽⁵⁾	Cleaning for special services			
Material Recommendations for NACE				
Standard				Standard
SG ⁽³⁾⁽⁶⁾	Sour Gas (Meets NACE MR 0175 / ISO 15156, MR 0103)			★
Typical Integral Manifold Model Number: 3 0 6 R T 2 2 B A 1 1				
Typical Transmitter Model Number: 3051TG3A2B21AS5B4				

(1) Only available with 316SST materials of construction and graphite-based packing.

(2) Not available with block-and-bleed manifold type

(3) Materials of Construction comply with recommendations per NACE MR0175/ISO 15156 for sour oil field production environments. Environmental limits apply to certain materials. Consult latest standard for details. Selected materials also conform to NACE MR0103 for sour refining environments.

(4) Includes graphite tape on plugs.

(5) Not available with Graphite-Based Packing Material code 2.

(6) Only available with 316 SST material of construction code 2. Manifolds with SG option are built with 316 SST body and bonnets; Alloy C-276 stems, tips/balls.

Rosemount Manifolds

OPTIONS

Module Guard

A sensor module guard is available to protect the transmitter process isolating diaphragms. This guard should be used whenever the transmitter is removed from the integral manifold to avoid damage to the isolating diaphragms.

- Part number: 00305-1000-0001 (5/pack)

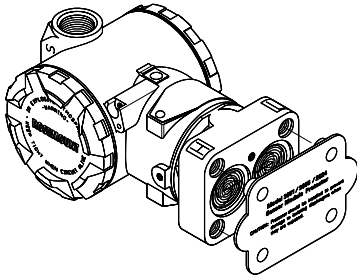

P2 Cleaning for Special Services

Per ASTM G93-96, this option minimizes process contaminants by cleaning wetted surfaces with a suitable detergent.

SG Sour Gas

Materials of Construction comply with recommendations per NACE MR 0175/ISO 15156 for sour oil field production environments. Environmental limits apply to certain materials. Consult latest standard for details. Selected materials also conform to NACE MR0103 for sour refining environments.

Heat Block Kits

Rosemount 304 Manifolds are available with steam heat block kits for cold environments and services. The steam block attaches directly to the manifold to prevent the process from freezing.

ASME B31.1 Power Piping Code

Rosemount Manifolds are available in configurations that meet the requirements of the ASME B31.1 Power Piping Code. This code specifies design criteria for most air, gas, steam, water, and oil systems used in electric generating systems, central and district heating systems, industrial power plants and geothermal plants. ASME B31.1 includes requirements for manifolds, valves, and piping. Transmitters and other measuring devices do not fall within the scope of this code.

Marking

Manifolds are tagged with a part number, schematic drawing, temperature and pressure limits.

Other Publications

For additional information, go to www.rosemount.com.

SPARE PARTS LIST

TABLE 13. Rosemount 304 Conventional Manifold

Part Description	Part Number (Traditional Style)	Part Number (Wafer Style)
Mounting Brackets (qty. 1)		
Manifold Heavy Duty Mounting Bracket, CS	01166-8005-0002	NA
Manifold Heavy Duty Mounting Bracket, SST	01166-8005-0001	NA
Manifold SST Mounting Bracket for 2-in. Pipe Mount	NA	00305-0405-0001
O-Rings (set of 12)		
Manifold-to-Flange O-Ring, Glass-filled PTFE	03031-0019-0003	03031-0019-0003
Manifold-to-Flange O-Ring, Graphite-filled PTFE	03031-1302-0002	03031-1302-0002
Manifold-to-Flange Bolt Kits (set of 4)		
Consult factory for part numbers	Consult Factory	Consult Factory
Heater Block Kits (qty. 1)		
Steam Block Kit	00305-0406-0001	NA

TABLE 14. Rosemount 305 Integral Manifold

Part Description	Part Number (Traditional Style)	Part Number (Coplanar Style)
Mounting Brackets (qty. 1)		
Manifold SST Mounting Bracket for 2-in Pipe Mount	NA	00305-0405-0001
Bolt Kits (set of 4)		
CS Bolt Kit	03031-0312-0001	03031-0311-0001
SST Bolt Kit	03031-0312-0002	03031-0311-0002
ANSI/ASTM-A-193-B7M Bolt Kit	03031-0312-0003	03031-0311-0003
Drain/Vents (qty. 1)		
316 SST Drain/Vent for use with 3-valve 305 Manifold	01151-0028-0012	01151-0028-0012
Alloy C-276 Drain/Vent for use with 3-valve 305 Manifold	01151-0028-0013	01151-0028-0013
Coplanar Flange Kits (qty. 1)		
Differential Flange Kit, SST	NA	00305-1001-0001
Gauge Flange Kit, SST	NA	00305-1001-1001
O-Rings (set of 12)		
Manifold-to-Module O-Ring, Glass-filled PTFE	03031-0234-0001	03031-0234-0001
Manifold-to-Module O-Ring, Graphite-filled PTFE	03031-0234-0002	03031-0234-0002
Sensor Guard (set of 5)		
Coplanar Module Sensor Guard	00305-1000-0001	00305-1000-0001

Rosemount Manifolds

Product Data Sheet
00813-0100-4733, Rev NA
April 2010

*Standard Terms and Conditions of Sale can be found at www.rosemount.com/terms_of_sale
The Emerson logo is a trade mark and service mark of Emerson Electric Co.
Rosemount and the Rosemount logotype are registered trademarks of Rosemount Inc.
Coplanar is a trademark of Rosemount Inc.
© 2009 Rosemount, Inc. All rights reserved.*