

Matrox

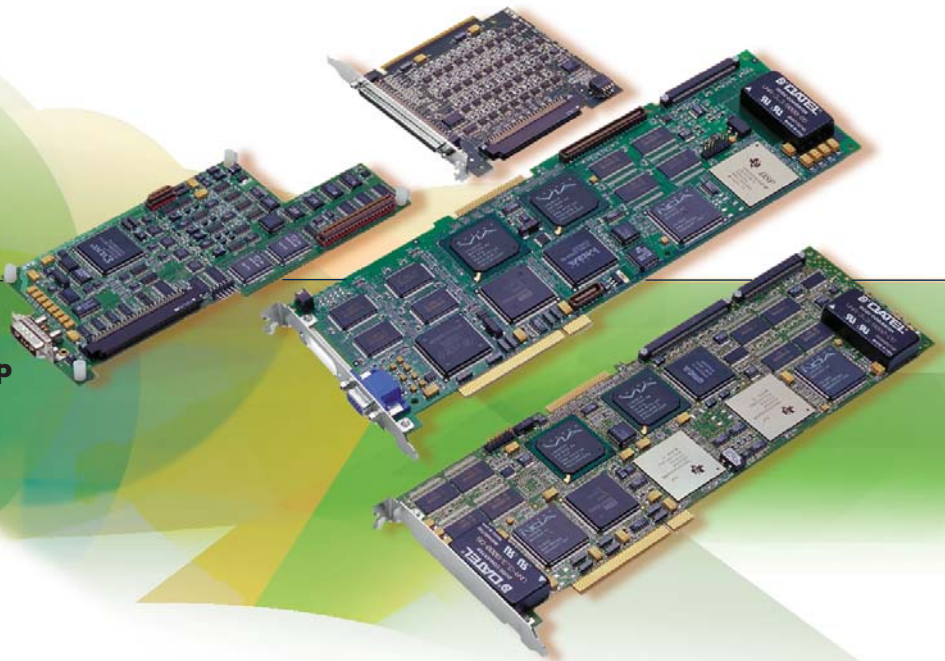

Genesis

**High-performance
imaging with speeds of up
to 100 billion operations
per second (BOPs).**



Main Board

Key features

- long PCI board integrating acquisition, processing and display
- Grab Module acquires from virtually any video device: color/monochrome, analog/digital, frame scan/line scan at up to 140 MHz sampling rate
- incorporates one processing node with:
 - Texas Instruments' TMS320C80 DSP
 - Matrox Neighborhood Operations Accelerator (NOA)
 - 64 MB SDRAM memory
 - 64-bit bus @ 400 MB/s¹
 - Matrox's Video Interface ASIC (VIA)
- display resolutions up to 1600 x 1200 @ 85Hz
- true-color image display with non-destructive pseudo-color overlay

Processor Board

Key features

- long PCI board containing one or two processing nodes
- used with Matrox Genesis Main Board for increased processing performance
- up to six Processor Boards can be used in one system
- interfaces directly to Main Board over the Grab Port Interface, VMChannel™ and the PCI bus
- can also be used as a powerful stand-alone processor board

Software

Key features

- the most comprehensive software available for a vision processor board
- extensive set of pre-built, high-level commands for image processing, pattern matching and blob analysis
- over 300 imaging operations are available, all fully optimized for accelerated processing by the C80/NOA combination
- Matrox Genesis Native Library Developer's Toolkit provides seamless integration of custom C80 code
- Matrox Imaging Library (MIL) has a consistent API across Matrox's line of imaging hardware

Key features

- flexible acquisition, real-time processing and high-resolution display all on one Main Board
- scalable processing - add more power by cascading Processor Boards as required for up to 100 BOPs performance
- user configurable multi-processing (parallel or pipeline or a combination)
- high-throughput I/O between acquisition, processing and display sections; between multiple boards and to external resources; handled by custom video interface ASIC (VIA)
- VIA offloads data management tasks from the vision processors allowing them to be completely dedicated to processing
- available software includes Matrox Imaging Library (MIL)/ActiveMIL, Matrox Genesis Native Library (GNL), Matrox Genesis Developer's Toolkit and Matrox Inspector
- support for Microsoft® Windows® NT 4.0, Windows® 2000, Windows® XP and QNX® (GNL only)



Matrox Genesis

State-of-the-art hardware components

Matrox Genesis vision processor is a unique design based on the PCI platform that uses Texas Instruments' TMS320C80 DSP. Our design exploits the full power of the C80 multi-processor DSP, the PCI bus, SDRAM memory, the MGA 2064W graphics accelerator and WRAM memory. Also onboard Matrox Genesis is a powerful ASIC dedicated to accelerating neighborhood operations. The advanced Grab Module can handle virtually any monochrome or color video stream. A key component in Matrox Genesis' design that links everything together is the Video Interface ASIC.

VIA: at the heart of Matrox Genesis

Custom designed by Matrox, the VIA (Video Interface ASIC) is an intelligent controller that performs optimized transfers between acquisition, display and processing sections in the Matrox Genesis system, as well as to and from external resources. It is also a powerful data formatting engine and is responsible for device synchronization. The Main Board and the Processor Board each have two VIAs

The VIAs let Matrox Genesis sustain high throughput I/O and allow the C80/NOA to be completely dedicated to processing, since the VIA off-loads all data management tasks.

The most comprehensive software available for a C80-based board

Matrox has extensive experience in providing software tools to meet the needs of developers in scientific and industrial imaging. We know what functions are required to solve machine vision, medical imaging and image analysis applications. Matrox Imaging Library (MIL) is a comprehensive image processing library that includes ActiveMIL, a collection of ActiveX controls (OCXs). Access to the board is also provided through the board-specific Matrox Genesis Native Library (GNL). All library functions have been fully optimized to exploit the full processing power and functionality of the hardware.

Main Board

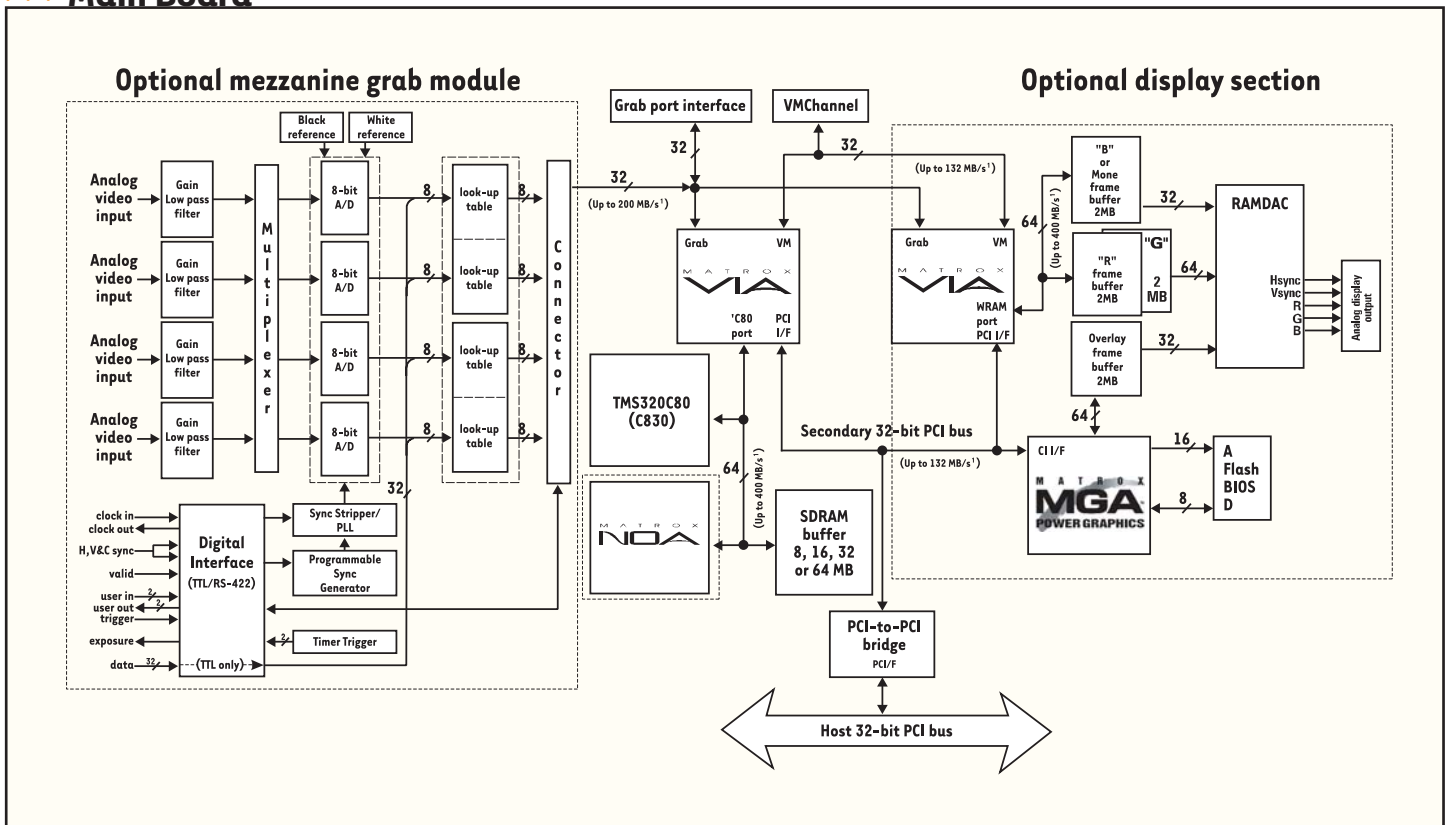

Processor Board

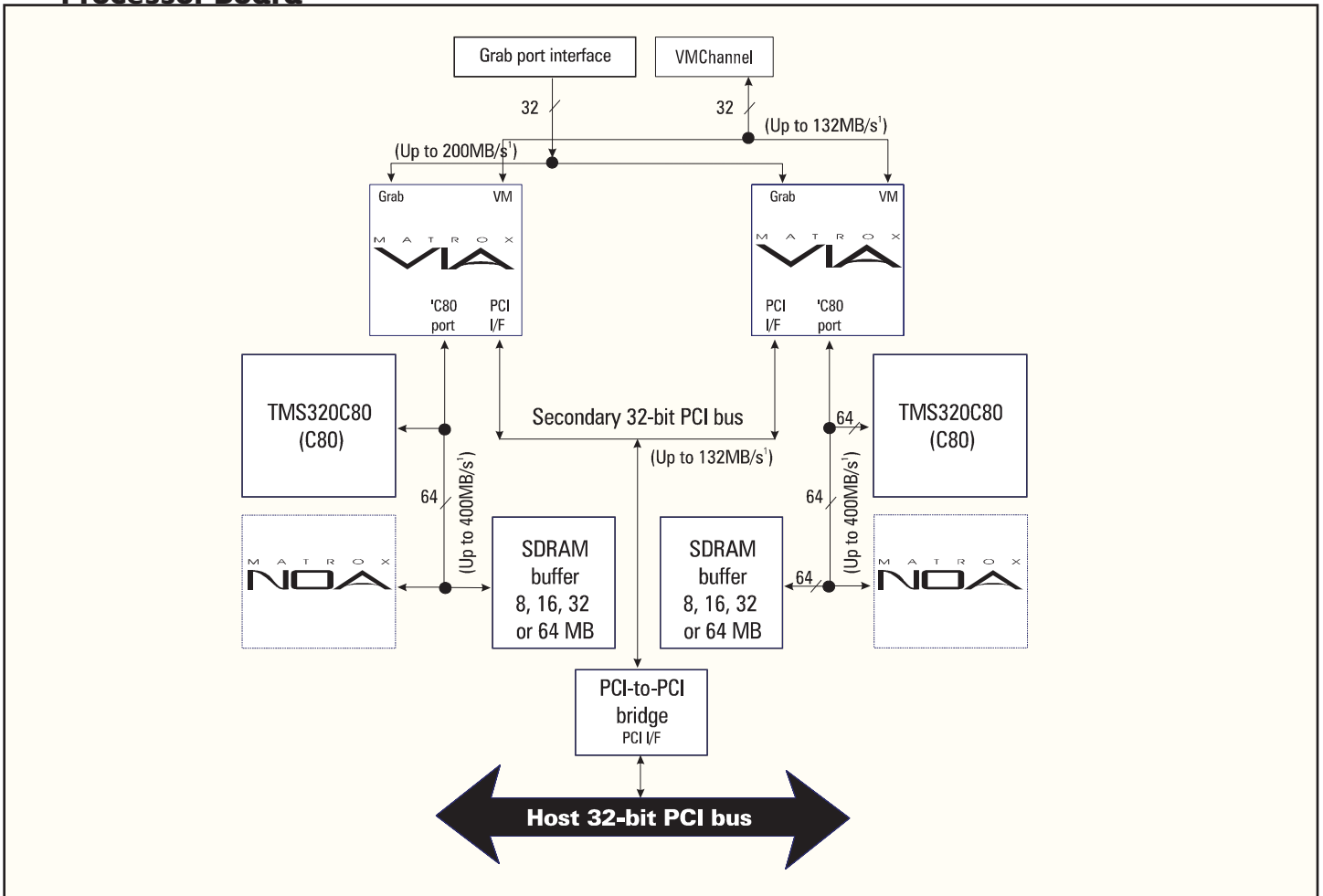

Acquisition

Key features

- analog acquisition at up to 140 MHz
- digital acquisition up to 32-bit wide
- TTL at up to 30 MHz, RS-422 at up to 25 MHz and LVDS at up to 40 MHz
- frame scan/line scan video input up to 64K pixels per line and 64K lines
- grabs color or monochrome video
- simultaneous capture of up to 4 video streams
- grabbed data written simultaneously to display and processing memory
- grabbed data broadcast to multiple processing nodes simultaneously (multi-board configuration)
- programmable acquisition synchronization
- external trigger input (TTL/RS-422/LVDS)
- exposure (timer) outputs (TTL/RS-422/LVDS)

Interfaces to virtually any camera or input device

Matrox Genesis provides exceptional flexibility for interfacing to a wide variety of devices, including

- high-resolution cameras (color or monochrome)
- line scan cameras including TDI (color or monochrome)
- medical scanners (ultrasound, CT, NM, MRI, X ray, etc.)
- slow-scan devices (e.g., SEM)
- frame reset cameras
- single or multi-tap cameras (time multiplexed or parallel streams)
- custom-designed input devices
- standard monochrome (RS-170/CCIR)
- standard component RGB cameras
- future video devices such as faster or higher resolution cameras

Designed specifically for industrial, medical or scientific applications

Matrox Genesis was built to handle high-speed machine vision that requires interfacing to double-speed progressive-scan cameras with single or dual video outputs. It also supports asynchronous reset capture with optional exposure control. For continuous web inspection, such as in the printing, wood, textile and steel industries, Matrox Genesis interfaces to both color and monochrome line scan cameras with very long line lengths (e.g., grab four streams of 64K lines) and can handle variable line rates. For medical imaging, Matrox Genesis acquires high rate analog or digital video at up to 140 MHz (e.g., MRI, CT, NM, etc.). For applications such as semiconductor inspection and biomedical analysis, the board supports interfacing to devices such as scanning electron microscopes.

Camera interface support

The Grab Module interfaces to a variety of standard/non-standard video cameras and devices. For a more extensive list of supported cameras, please refer to the Matrox Imaging web site, www.matrox.com/imaging. Matrox provides digitizer configuration files (DCFs) and detailed application notes for many cameras. For interfacing to other cameras, developers can use Matrox Intellicam camera configuration software to build or modify DCFs.

Analog video monochrome

Matrox Genesis Grab Module has 4 A/D converters and can be configured to capture standard or non-standard monochrome video signals in 3 software-selectable modes:

- 4 channel/8-bit mode at up to 35 MHz
- 2 channel/8-bit mode at up to 70 MHz
- 1 channel/8-bit mode at up to 140 MHz

For all modes, each A/D converter is software programmable for coarse and fine adjustment of level and reference voltages as well as clamping.

color

In the 4 channel/8-bit mode, Matrox Genesis Grab Module can capture standard component RGB or non-standard component RGB color video signals. In addition to an RGB camera, which requires 3 input channels, a separate analog stream for sync input could use the fourth channel or a single-readout monochrome camera may be connected to the fourth input channel. Both the RGB and monochrome cameras, however, must be externally synchronized. The video signals are simultaneously digitized to 8-bits at a sampling rate of up to 35 MHz.

Digital video data

The Grab Module can acquire 32-bit digital video data at a rate of up to 40 MHz in one of several configurations: four 8-bit channels, two 16-bit channels or one 32-bit channel. An optional companion board is required for digital video data acquisition in RS-422/LVDS format.

Processing Key features

- processing is performed by TI's TMS320C80 (C80) and the Matrox-designed Neighborhood Operations Accelerator ASIC (NOA)
- C80 is capable of accelerating the full range of operations used in imaging applications, for example: point-to-point, neighborhood, statistical, geometric, blob analysis and pattern matching operations
- NOA further accelerates neighborhood operations

TI's C80 key features:

- one 32-bit RISC Master Processor (MP) with integral FPU
- four 32-bit integer Advanced DSPs (parallel processors or PPs)
- 32 KBytes of internal RAM shared among processors (50 KBytes total)
- crossbar for optimal internal connectivity
- transfer controller for high performance external I/O
- 50 MHz system clock
- internal FPU capable of 100 MFLOPS
- up to 2 billion RISC-like operations per second
- 2.4 GBytes sustainable on-chip data transfer rate
- 400 MB/s off chip peak transfer rate

Matrox's NOA key features:

- Performs:
 - convolutions
 - gray-scale morphology
 - binary morphology
 - normalized gray-scale correlations
 - lossless JPEG codec
- consists of a MAC (multiplier/accumulator) array capable of performing 32 simultaneous sums of products at 50 MHz
- accelerates operations up to 20 times compared to C80

Processing nodes

Processing nodes are the basic building blocks of Matrox Genesis' processing power. The Main Board has one processing node while the Processor Board has one or two processing nodes. A node contains the following:

- C80 DSP
- Neighborhood Operations Accelerator (NOA) ASIC
- 64 MB SDRAM
- Video Interface ASIC (VIA)

The processing node's local bus transfers data at up to 400 MB/s¹ between the C80/NOA and the local SDRAM memory. The VIA manages these transfers and transfers to/from acquisition, display and other processing nodes.

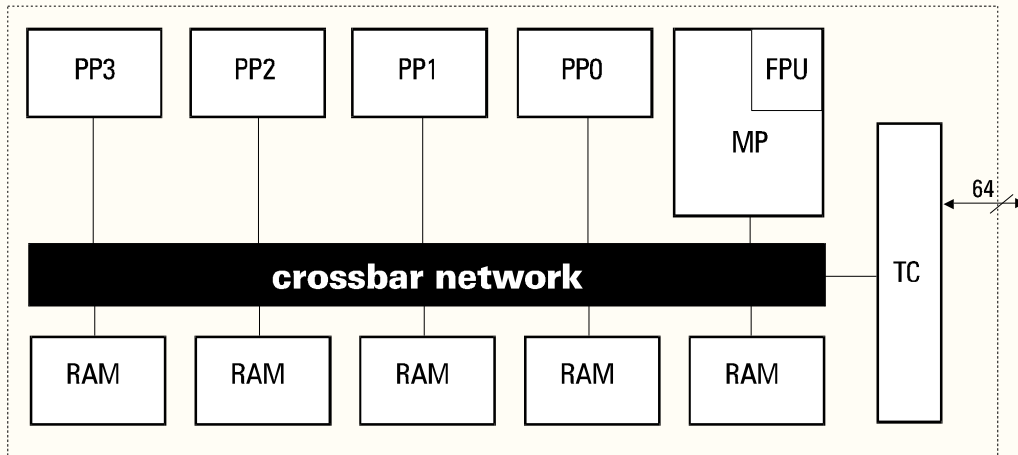

- PP0-3 : Parallel processors 0-3 (advanced DSP, 32-bit integer units)
- MP : Master processor (32-bit RISC processor with an IEEE-754 FPU)
- FPU : Floating-point unit
- TC : Transfer controller (transfers data between external and internal memory)
- RAM : On-chip memory
- Crossbar Network: High-speed bus switching network between processors and RAM

Scalable processing: add multiple processing nodes by adding processor board(s)

- configure a system with a Main Board and a Processor Board for a total of two to three nodes
- up to a maximum of 6 Processor Boards can be added for more power
- incoming images are broadcast to all processing nodes so that each can perform the required operation on a designated part or whole of the image

Transparent multi-processing: processing automatically optimized within a node

- each node has multiple processors - one C80 with 4 PPs, 1 MP and one NOA
- intelligent image processing functions automatically divide up a task among the multiple processors to achieve maximum speed
- the user does not have to optimize the use of processors within a single node
- commands for control are provided to override task distribution

Configurable multi-processing: parallel or pipeline processing

- developer has complete control to optimally configure the processing across multiple nodes
- multiple nodes can be used in parallel, either using the SIMD (single instruction, multiple data) model or the MIMD (multiple instruction, multiple data) model
- there are several different ways to divide an application between nodes, for example:
 - let each node grab a different part of the same input frame and work only on that
 - let each node grab and process a complete frame with each successive frame going to a different node
 - dedicate one node to grabbing and let it do the first part of the processing before passing the partial results on to the next node in the pipeline
- Matrox Genesis supports parallel or pipeline topologies or any combination
- multi-processing designed to be completely configurable since the best approach depends on the individual application

Processing Nodes

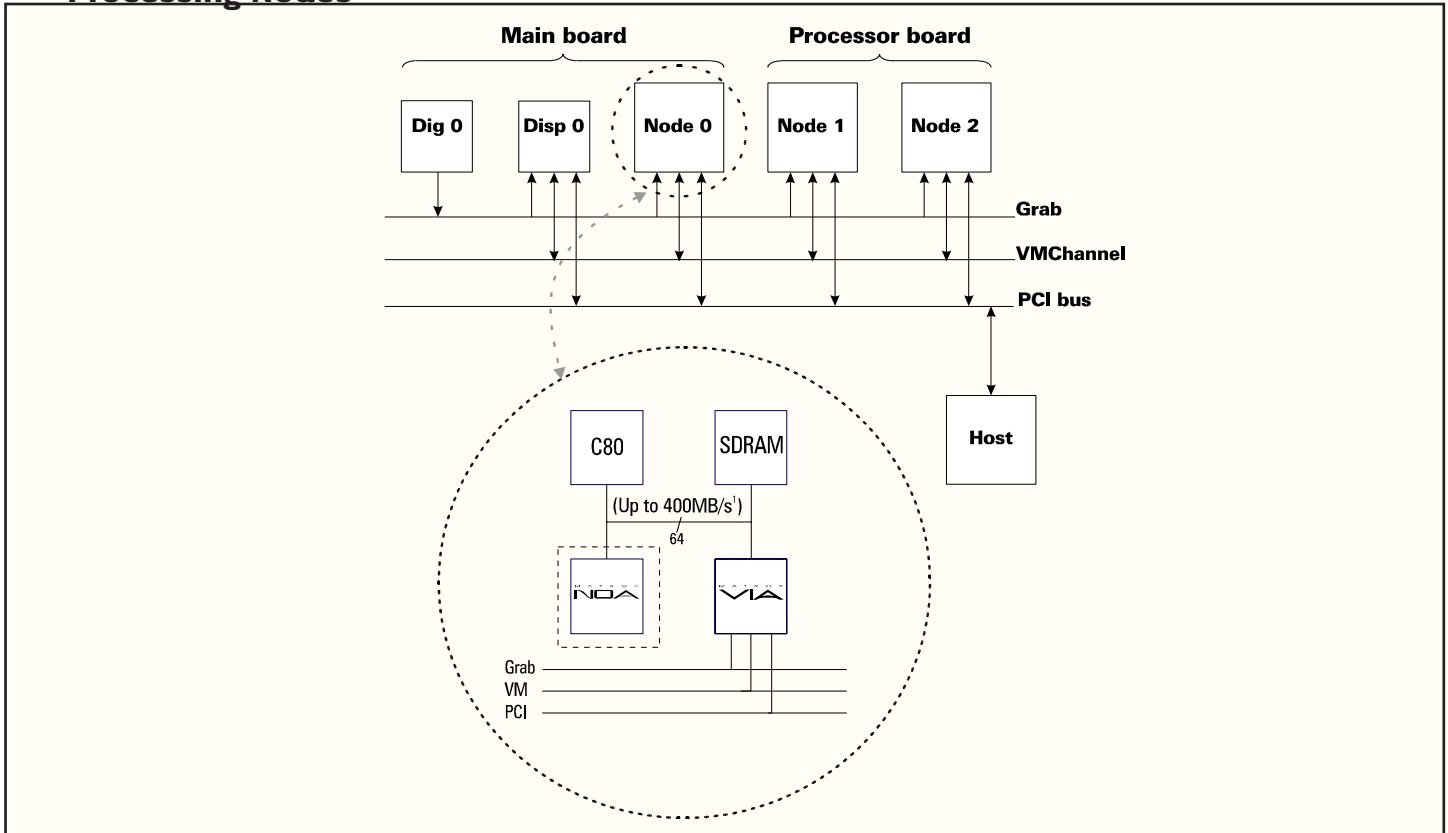

Data Management

To achieve real-time performance, an imaging subsystem must be able to handle the demanding interface requirements for simultaneous acquisition, processing and display of high-speed video. Matrox Genesis was specifically designed to sustain high throughput I/O. Dedicated high-speed buses transfer data between devices on the board, as well as between boards (i.e., Main Board and Processor Board) and to and from external resources (e.g., host PC). The video interface ASIC (VIA) manages all data interface and performs efficient transfers. It also performs real-time data formatting.

Dedicated high-speed data buses

- 200 MB/s (32-bit) grab port interface for acquiring high-rate video and, in a multi-board configuration, simultaneously broadcasting the image to all processing nodes
- 132 MB/s (32-bit) VMChannel™ for transferring images between processing and display sections and, in a multi-board configuration, between processing nodes (the VMChannel™ supports connection of up to 13 devices, e.g., one Main Board and six Processor Boards)
- 400 MB/s (64-bit) local memory bus between processors (C80/NOA) and memory (SDRAM)
- 400 MB/s (64-bit) local memory bus between display controllers (MGA/VIA) and memory (WRAM)
- 132 MB/s (32-bit) PCI bus for transferring data (e.g., synchronization information) between boards

Video interface ASIC (VIA)

key features

- integrates the following interfaces:
 - 32-bit/50 MHz grab port
 - 32-bit/33 MHz PCI bus Master/Slave interface
 - 32-bit/33 MHz Controller/Master/Slave VESA Media Channel
 - 64-bit/50 MHz glue-less SDRAM or WRAM memory port
- manages up to two concurrent data streams:
 - grabs to onboard memory with concurrent transfer between onboard memory and VMChannel™ or PCI
 - PCI data transfers can be concurrent with host processor access to onboard memory
- implements memory bus arbitration
- with the VIA's grab port, grabbed data is queued in the on-chip FIFO and then burst to SDRAM so the processing is not slaved to the speed of the acquisition
- takes non-consecutive pixel data and reconstructs it in memory in real time (e.g., from time multiplexed or multitap cameras, etc.)
- writes to WRAM, performing sub-sampling, zooming and tagging
- enables efficient inter-processor communication: one C80 has access to all of the host memory and the memory bank of all other C80s that are present in a multi-board system
- offloads data management tasks from the C80 so the DSP is completely dedicated to processing
- PCI bus master interface with support for scatter-gather DMA

Display

Key features

- supports high-resolution monochrome or color display
- separate image buffer and overlay buffer for non-destructive overlay
- up to 1600 x 1200 x 8-bit or 24-bit image display
- up to 1600 x 1200 x 8-bit pseudo-color overlay display
- display memory completely independent of processing memory
- supports live display of processed images

Software

Matrox offers the most comprehensive image processing software available for a vision processor board.

Programming levels

By providing three different programming levels, Matrox meets the needs of a range of developers.

1. MIL/ActiveMIL

- complete programming library for image capture, transfer, processing, analysis and display
- fully exploits Intel MMX™ technology or Matrox vision processors
- applications easily ported to new hardware platforms
- processing performed to sub-pixel accuracy
- multi-processing and multi-threading support
- available as DLL for Microsoft® Windows® NT 4.0, Windows® 2000 and Windows® XP
- includes Matrox Intellicam camera configuration utility

2. Matrox GNL

- board-specific 'C' library
- available as DLL for Microsoft® Windows® NT 4.0, Windows® 2000, Windows® XP and LIB for QNX®
- works with Matrox Genesis only
- accelerates MIL functions
- fully optimized for accelerated processing by the C80/NOA combination
- automatically divides up tasks between parallel processors and the NOA (override control commands provided, if required)
- suits the needs of developers who do not require a portable application
- Native Library commands can also be used within a MIL application
- does not require extensive knowledge of the C80 or DSP programming

3. GNL Developer's Toolkit (DTK)

- used in conjunction with Texas Instruments' C8x software development tools
- programs the C80 directly (MP or PPs)
- suits the needs of developers who must integrate native C80 code
- provides a model for developing custom functions that behave as existing GNL functions

Protects your investment in software development

Matrox developed MIL specifically for leading-edge developers facing increasing competitive pressures to reduce costs and decrease time to market. With MIL, original software development takes less time and provides long-term benefits. Matrox pioneered the concept of portable software tools that allow a smooth upgrade to new hardware platforms. The investment you make in development today will pay off long into the future.

For most MIL functions there is a corresponding Native Library function. However, some functions are only available through MIL (e.g., gauging, OCR, bar and matrix code reading, calibration, and video-in-a-window management). Also, Native Library offers some board-specific functions. When used with Matrox Genesis, MIL functions make calls to GNL, which executes operations on the processing node(s). The objective in developing mainly with MIL functions is that most of the application will be portable. Moving the application later to a different platform will require changing only the board-dependent portion of the code.

MIL

Common API across hardware

Hardware-independent MIL is compatible with any VGA card and Matrox's line of PCI imaging hardware, from low-cost frame grabbers to Matrox Genesis vision processor. It not only works with Matrox's current line of hardware, but with future imaging boards as well. The applications you write with MIL today can be reused on the PC or Matrox platforms of tomorrow.

Optimum use of hardware resources

When used with Matrox Genesis, MIL commands make calls to GNL commands with little overhead. Performance will be virtually the same using equivalent MIL or GNL commands.

Transparent hardware management

MIL automatically executes operations using whatever hardware is available in the system, host CPU or onboard processors.

Multi-processing and multi-threading

MIL supports multi-process and multi-tasking programming models. Multiple MIL applications not sharing MIL data or a single MIL application with multiple threads sharing MIL data can run under Windows® NT 4.0/2000/XP.

MIL provides synchronization mechanisms to access shared MIL data and ensure that multiple threads using the same MIL resources do not interfere with each other. These capabilities, coupled with Windows® NT 4.0/ 2000/ XP, enable the creation of applications that distribute workload across several CPUs in a multi-processor PC or multi-node Matrox Genesis platform.

Comprehensive set of imaging functions

MIL has a modular architecture, with modules for application and board control, as well as:

- Image Processing
- Blob Analysis
- Compression/decompression
- Measurement
- Geometric Model Finder
- Pattern Matching
- OCR
- Bar & Matrix Code Module
- Camera Auto-focus Tool
- Calibration Module

Matrox Genesis Native Library

Like MIL, Native Library has over 300 commands for image processing, blob analysis, pattern matching, etc., along with additional commands that take advantage of the board's specific architecture. If portability is not a requirement, the entire application can be developed with Native Library.

Matrox Genesis Native Library is a set of stub routines, one for each supported opcode. Native Library commands are initiated by the host and make remote procedure calls to the actual processing functions on the C80 (the Native Library "Shell" resides in the onboard SDRAM processing memory). Tasks are automatically divided among the multiple processors (the C80's, PPs and NOA). A set of commands is provided for controlling the use of the processors.

Additional functionality (beyond MIL) includes:

- functions for hardware-specific features of the board (e.g., some hardware formatting features of the VIA)
- compound functions that perform several operations with only one call (e.g., `imIntTriadic()` is a function that takes 3 input arguments and processes them in a single pass)
- functions for finer control of parallelism (e.g., execute one operation on one of the C80 parallel processors (PP) and one operation can be split between the other PPs)
- the ability to develop an application under an environment not supported by MIL

Matrox GNL DTK

The DTK provides the ability to integrate Native C80 code into an application. This is required when porting the control application from the host to the C80's MP (so that the host does not have to be involved in real-time control) or developing custom PP functions. The DTK is used in conjunction with Texas Instruments' C8x development tools.

Programming the MP in 'C' does not require detailed knowledge of the C80 and the user has access to all Native Library functions. For programming the PPs, some knowledge of the internal architecture of the C80 is required, including the workings of the Transfer Controller and the Parallel Processors. It usually also requires programming in assembly language to achieve maximum performance.

The GNL DTK is designed to remove much of the complexity of programming at the lowest level. It presents a model for writing new processing functions that behave exactly as existing Native Library functions. By following this model, developers can concentrate their efforts on the heart of the function - the relatively small amount of PP assembly code that implements the algorithm (the so-called critical loop).

See Matrox Genesis Developers' Toolkit brochure for more information.

Software Architecture

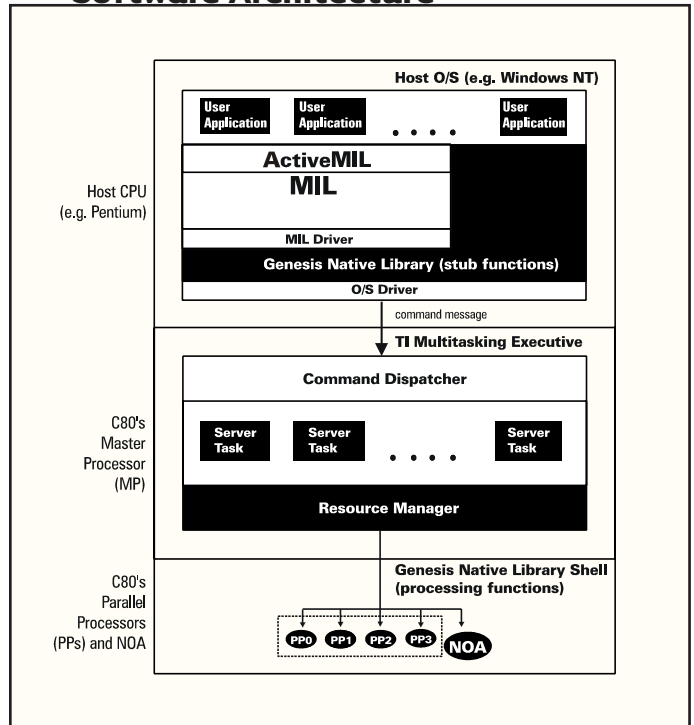

Data types

Supported data types include binary (1-bit per pixel), 1-band and 3-band (color) integer including 8-, 16- or 32-bit (signed or unsigned), floating point and RGB packed; and commands for converting between data types.

Hardware Specifications

Acquisition

- monochrome or color, standard or non-standard, analog or digital
- frame scan or line scan
- up to 64K pixels per line and 64K lines

analog

- 3 software-selectable modes
 - 4 channel/8-bit mode at up to 35 MHz
 - 2 channel/8-bit mode at up to 70 MHz
 - 1 channel/8-bit mode at up to 140 MHz
- PLL range: 5-35 MHz
- programmable clock phase: 0°, 90°, 180° and 270°
- programmable gain, offset and DC restoration

digital

- onboard up to 32-bit wide TTL input at up to 30 MHz
- optional digital input companion board provides up to 32-bit wide RS-422 at up to 25 MHz and LVDS at up to 40 MHz

preprocessing

- 10 MHz low pass filter (can be bypassed)

synchronization and control

- hsync, vsync, composite sync, pixel clock input or output (TTL/RS-422/LVDS)
- external trigger input (TTL/RS-422/LVDS)
- two exposure (timer) outputs (TTL/RS-422/LVDS)
- auxiliary I/Os (TTL/RS-422/LVDS): two in/two out

configurable look-up tables

- four 256 x 8-bit or two 8k x 16-bit

Processing node

- TI's TMS320C80 DSP @ 50 MHz
- Matrox's Neighborhood Operations Accelerator (NOA) @ 50 MHz
- 64 MB SDRAM
- Matrox Video Interface ASIC (VIA)
- up to 13 nodes in a system

Data interface

- custom Matrox Video Interface ASIC (VIA) performs optimized transfers between acquisition, display and processing; between boards, and to external resources (i.e., host)
- VIA offloads C80 from all data management
- up to 400 MB/s¹ processing memory bandwidth (64-bit/50 MHz)
- up to 400 MB/s¹ display memory bandwidth (64-bit/50 MHz)
- up to 132 MB/s¹ VMChannel™ bandwidth (32-bit/33 MHz)
- up to 132 MB/s¹ PCI bus transfer rates (32-bit/33 MHz)
- up to 200 MB/s¹ grab port interface (32-bit/50 MHz)

Display section

- Matrox MGA 2064W graphics engine
- 6 MB WRAM image frame buffer
- 2 MB WRAM overlay frame buffer
- resolutions up to 1600 x 1200 @ 85 Hz refresh rate
- supports 1200 x 1600 portrait display mode
- non-destructive overlay of text and graphics

Connector pinouts

To see connector pinout diagrams for the Matrox Genesis family of boards, please visit the product section of the Matrox Imaging web site: www.matrox.com/imaging/products/genesis/

Dimensions and environmental information

Main board

- 31.4 L x 10.7 H x 1.99 W² cm (12.4" x 4.2" x 0.78")
H: bottom edge of goldfinger to top edge of board
- 34.1 L x 10.7 H x 1.99 W² cm (13.4" x 4.2" x 0.78")
includes retainer
- Power consumption: 4.7A @ 5V or 23.5W; 230mA @ 12V or 2.76W; 145.4mA @ -12V or 1.75W (GEN/F/64/8/STD)

Processor board

- 31.4 L x 10.7 H x 1.73 W cm (12.4" x 4.2" x 0.68")
H: bottom edge of goldfinger to top edge of board
- 34.1 L x 10.7 H x 1.73 W cm (13.4" x 4.2" x 0.68")
includes retainer Power consumption
- 4.13A @ 5V or 20.65W (GPRO/F/64/F/64)
- 2.29A @ 5V or 11.45W (GPRO/F/64)

Main board/processor board

- operating temperature: 0° C to 55° C (32° F to 131° F)
- relative humidity: up to 95% (non-condensing)

Software Environment

- host driver for Microsoft® Windows® NT 4.0, Windows® 2000, Windows® XP and QNX®
- Windows® development done using DLL interface (MIL and GNL) with Microsoft® Visual C++® or ActiveX interface (ActiveMIL) with Microsoft® Visual Basic® or C++®
- QNX® (GNL only) development done using LIB interface with QNX® IDE
- custom code development for the C80 done using GNL DTK with Texas Instruments C80 software development tools

Ordering Information

Part number

Description

Hardware: Main Board

GEN/F/64/8/STD or LVDS	PCI vision processor with C80/NOA/64MB, integrated 8 MB display and standard/non-standard analog color/monochrome line/frame scan acquisition.
GEN-DIG-BRD/X/Y	Digital input companion board. X is R for RS-422 and L for LVDS (requires/LVDS option). Y is P for PCI and I for ISA.
GEN-CBLADT/PCI	Digital cable adapter board for the PCI form factor.

Hardware: Processor Board

GPRO/F/64/F/64	PCI processor board with two C80/NOA/64MB nodes.
GPRO/F/64	PCI processor board with single C80/NOA/64MB node.

PCB back planes

GEN-BUS/2	VMC and GP2 back planes for two boards.
GEN-BUS/3	VMC and GP2 back planes for three boards.
GEN-BUS/4	VMC and GP2 back planes for four boards.

Ordered separately:

Software

GENESIS/SW/CD	Matrox Genesis Native Library and DTK (requires access code included in Genesis/DTK), MIL-Lite/ActiveMIL-Lite, Matrox Intellicam, MGA drivers, and on-line/printed manuals.
GEN-SW/QNX/CD	Matrox Genesis Native Library for QNX and GENESIS/SW/CD.
GENESIS/DTK	Matrox Genesis Developer's kit (includes access code)
MIL 7 DEV P or U	Matrox Imaging Library (MIL) (see MIL brochure for more details).

Maintenance program

Each purchase of GENESIS/SW/CD includes one year of the Genesis Native Library Maintenance Program. The program entitles registered users to one year of technical support and free updates, and may be renewed at the end of the first year.

GEN/MAINTENANCE	One year program extension.
-----------------	-----------------------------

Analog input cables

IMG-7W2-TO-5BNC	2.4 m (8') input cable, one 7W2 to five BNCs.
-----------------	---

Digital input cables

DBHD100-TO-OPEN	3 m (10') input cable, high density DB-100 to an open end (requires customization).
DBHD-68-TO-OPEN	3.6 m (12') DBHD-68 to an open end (for synch and control only).

Custom camera cables are available. Contact Matrox Imaging Sales for more information.

Notes:

1. Bus speeds given are maximum theoretical transfer rates.
2. Includes required space for screws and nylon washers which are non-conductive.

matrox

For more information, please call: **1-800-804-6243 (toll free in North America)**
or **(514) 822-6020** or e-mail: imaging.info@matrox.com or <http://www.matrox.com/imaging>

Corporate headquarters:

Canada and U.S.A.
Matrox Electronic Systems Ltd.
1055 St. Regis Blvd.
Dorval, Quebec H9P 2T4
Canada
Tel: (514) 685-2630
Fax: (514) 822-6273

Offices:

Europe, Middle East & Africa
Matrox VITE Limited
Sefton Park
Stoke Pages
Buckinghamshire
SL2 4JS
U.K.
Tel: 01753 665511
Fax: 01753 665599

France
Matrox France SARL
2, rue de la Couture
Silic 225
94528 Rungis Cedex
Tel: (0) 1 45-60-62-00
Fax: (0) 1 45-60-62-05

Germany
Matrox Electronic Systems GmbH
Inselkammerstr. 8
D-82008 Unterhaching
Germany
Tel: 089/62170-0
Fax: 089/614 9743

All trademarks by their respective owners are hereby acknowledged. Matrox Electronic Systems, Ltd. reserves the right to make changes in specifications at any time and without notice. The information furnished by Matrox Electronic Systems, Ltd. is believed to be accurate and reliable. However, no responsibility license is granted under any patents or patent rights of Matrox Electronic Systems, Ltd. Windows and Microsoft are trademarks of Microsoft Corporation. MMX and the MMX logo are registered trademarks of Intel Corporation. Printed in Canada, 05-12-2003. **51E-4915-B**