

SCREW:	MATERIAL: COPPER, W106804	TOLERANCES-UNLESS OTHERWISE SPECIFIED 2 PL. DEC. ±.010 TRUE C.L. ±.015 3 PL. DEC. ±.005 ANGLES ±1		DWG. NO. F0013	
CAT. NO.:	PLATING: BRIGHT DIP	DRAWN BY: JG	SCALE: 3=1	SHEET 1 OF 1	
MASS: .0095 LBS	MARKING: SEE CHART	DATE: 6/4/2007	SIZE: A		
SURFACE AREA: 1.2800 IN					
STUFFER SHT:	CELL: CPO				

REV.	DESCRIPTION
C	

Cat #: SLU-35
SLU-35-B2

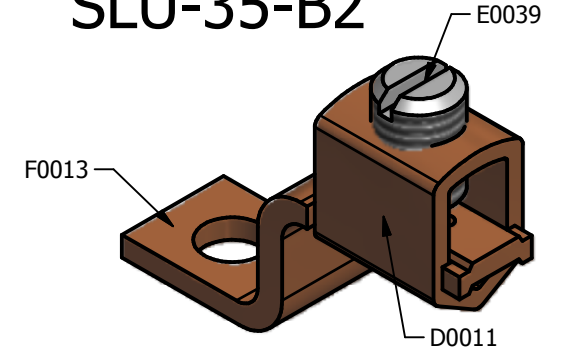
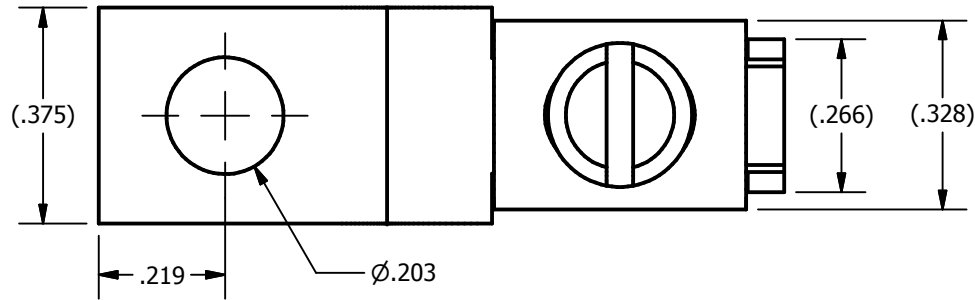

SCALE 2 : 1

