

Screw Terminal Ultra-Slim Signal Conditioners M6N Series

0: Specify voltage (See OUTPUT SPECIFICATIONS)

FREQUENCY TRANSMITTER

Functions & Features

- 7.5-mm wide ultra-slim design
- Low profile allows the M6N module mounted in a 120-mm deep panel
- Converts the output from a pulse-type transducer into a standard process signal
- High-density mounting
- Power indicator LED
- UL approval

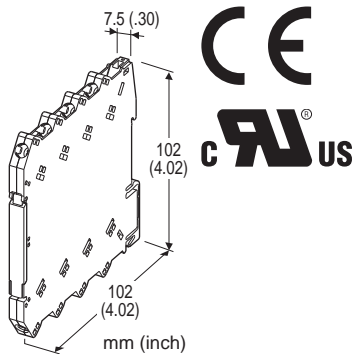

MODEL: M6NPA-[1][2]-R[3]

ORDERING INFORMATION

- Code number: M6NPA-[1][2]-R[3]
Specify a code from below for each [1] through [3].
(e.g. M6NPA-CA-R/UL)
- Frequency range (e.g. 0 - 1 kHz)
- Special output range (For codes Z & 0)

[1] INPUT

- A1: Open collector
- A2: Mechanical contact
- C: 5 V pulse (sensitivity 2 V)
- D: 24 V pulse (sensitivity 10 V)

[2] OUTPUT

Current

- A: 4 - 20 mA DC (Load resistance 550 Ω max.)
- Z: Specify current (See OUTPUT SPECIFICATIONS)

Voltage

- 4: 0 - 10 V DC (Load resistance 10 kΩ min.)
- 5: 0 - 5 V DC (Load resistance 5000 Ω min.)
- 6: 1 - 5 V DC (Load resistance 5000 Ω min.)
- 4W: -10 - +10 V DC (Load resistance 20 kΩ min.)
- 5W: -5 - +5 V DC (Load resistance 10 kΩ min.)

POWER INPUT

DC Power

R: 24 V DC

(Operational voltage range 24 V ±10 %, ripple 10 %p-p max.)

[3] OPTIONS

STANDARDS & APPROVALS

blank: CE marking

/UL: UL approval (CE marking)

GENERAL SPECIFICATIONS

Connection

Input and output: M3 screw terminal (torque 0.5 N·m)

Power input: Via the Installation Base (model: M6NBS) or M3 screw terminal (torque 0.5 N·m)

Recommended solderless terminal: Max. 5.8 mm (0.23") wide; Ones with insulation sleeve do not fit.

Applicable wire size 0.2 - 2.5 mm²

Housing material: Flame-resistant resin (black)

Isolation: Input to output to power

Zero adjustment: -2 to +2 % (front)

(Output code 4W, 5W: Adjustable at 0V.)

Span adjustment: 98 to 102 % (front)

Chattering protection: Filter provided for mechanical contact input

Power LED: Green light turns on when the power is supplied.

■ Recommended solderless terminal

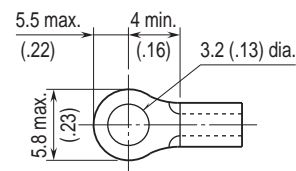

INPUT SPECIFICATIONS

• Open Collector

Frequency range: 0 - 0.01 Hz through 100 kHz

Pulse width time requirement: ≥ 4 μsec. for both H and L levels

Sensing voltage/current: 2.5 V DC @1 mA (approx.)

Detecting levels: ≤ 750 Ω for ON; ≥ 3 kΩ for OFF

• Mechanical Contact

Frequency range: 0 - 0.01 Hz through 30 Hz

Pulse width time requirement: ≥ 10 msec. for both ON and OFF

Sensing voltage/current: 2.5 V DC @1 mA (approx.)

Detecting levels: ≤ 750 Ω for ON; ≥ 3 kΩ for OFF

• Voltage Pulse

Frequency range: 0 - 0.01 Hz through 100 kHz

Pulse width time requirement: $\geq 4 \mu\text{sec.}$ for both H and L levels

Waveform: Square or sine

Input impedance: $\geq 10 \text{ k}\Omega$

Max. voltage between input terminals: $\pm 50 \text{ V}$

Detecting H level

5 V pulse: $\geq 3 \text{ V}$

24 V pulse: $\geq 14 \text{ V}$

Detecting L level

5 V pulse: $\leq 1 \text{ V}$

24 V pulse: $\leq 6 \text{ V}$

OUTPUT SPECIFICATIONS

• **DC Current:** 2 - 20 mA DC (and 0 - 1 mA DC)

Minimum span: 1 mA

Offset: Max. 1.5 times span

Load resistance: Output drive 11 V max.

• **DC Voltage:** 0 - 10 V DC

Minimum span: 1 V

Offset: Max. 1.5 times span

Load resistance: Output drive 1 mA max.; at $\geq 1 \text{ V}$

INSTALLATION

Power consumption: Approx. 0.5 W

Operating temperature: -20 to +55°C (-4 to +131°F)

Operating humidity: 30 to 90 %RH (non-condensing)

Mounting: Installation Base (model: M6NBS) or DIN rail

Weight: 60 g (2.1 oz)

PERFORMANCE in percentage of span

Accuracy: $\pm 0.1 \%$

Temp. coefficient: $\pm 0.015 \%/^{\circ}\text{C}$ ($\pm 0.008 \%/^{\circ}\text{F}$)

Response time: Max. 0.5 sec. + 1 pulse cycle (0 - 90 %)

Line voltage effect: $\pm 0.1 \%$ over voltage range

Insulation resistance: $\geq 100 \text{ M}\Omega$ with 500 V DC

Dielectric strength: 2000 V AC @1 minute (input to output to power to ground)

STANDARDS & APPROVALS

CE conformity:

EMC Directive (2004/108/EC)

EN 61000-6-4 (EMI)

EN 61000-6-2 (EMS)

Approval:

UL/C-UL nonincendive Class I, Division 2,
Groups A, B, C, and D hazardous locations
(ANSI/ISA-12.12.01, CAN/CSA-C22.2 No.213)

UL/C-UL general safety requirements
(UL 61010-1, CAN/CSA-C22.2 No.61010-1)

EXTERNAL VIEW

(With the cover open)

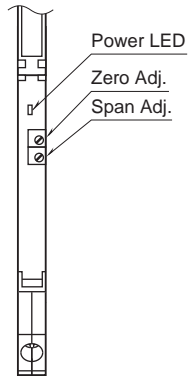

DIMENSIONS unit: mm (inch)

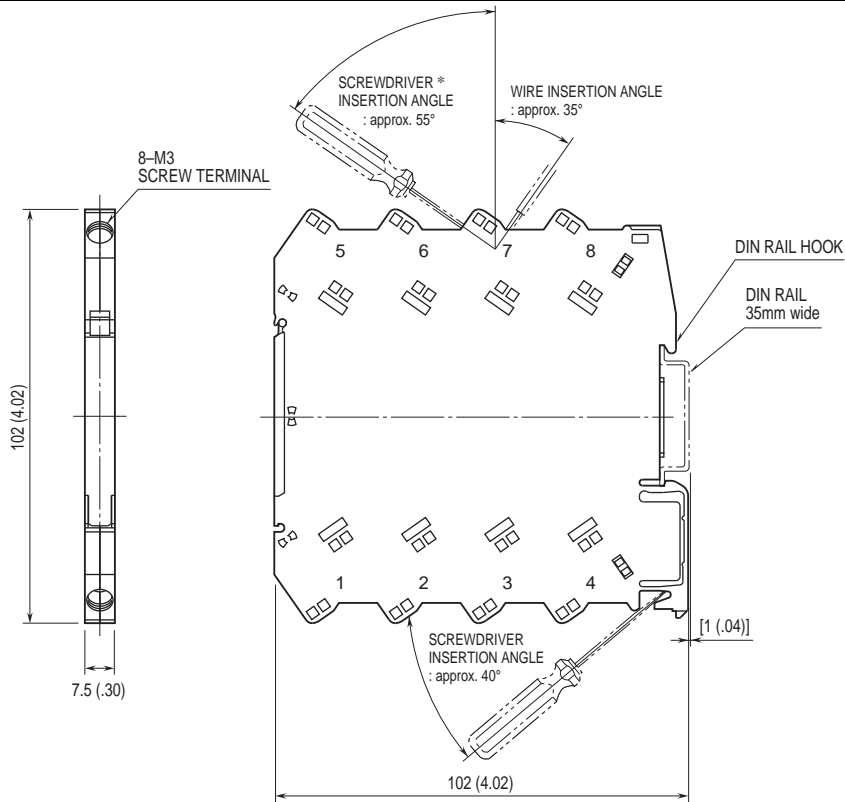

*Screwdriver stem diameter: 6 mm (.24") or less

• When mounting, no extra space is needed between units.

SCHEMATIC CIRCUITRY & CONNECTION DIAGRAM

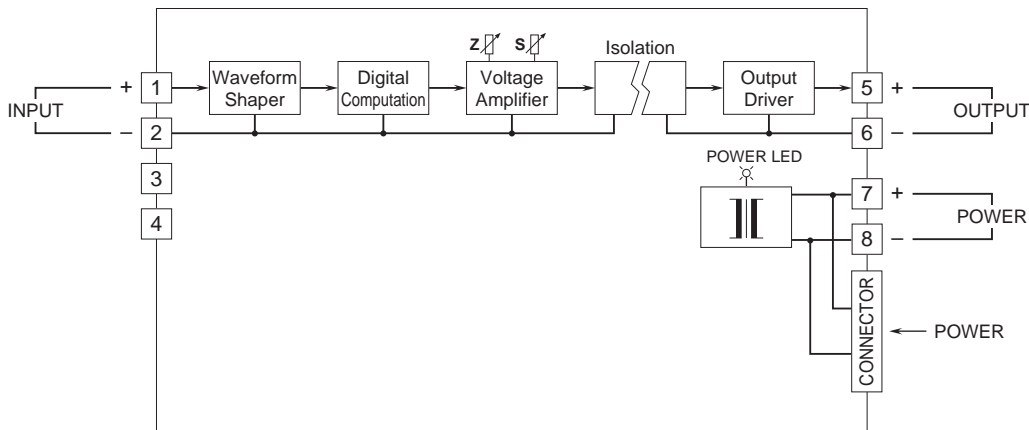

Input Connection Examples

■ Open Collector or Mechanical Contact ■ Voltage Pulse

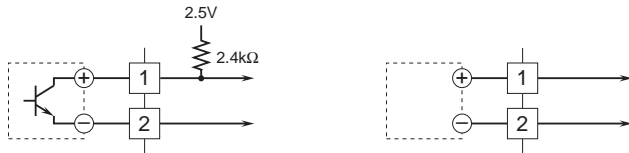

Specifications are subject to change without notice.