



Emergency Battery System

XL243B

Securaplane's Sealed Lead Acid XL243B emergency battery system is designed to provide emergency backup DC power to avionics and lighting systems. The emergency battery with its integral sealed lead batteries also provides battery charge control to insure high reliability, low maintenance, extended battery service life and overall safety. The XL243B also includes integral electronic circuitry to provide status monitoring and diagnostics of the emergency battery system to aid in aircraft maintenance and troubleshooting tasks.

Advantages

- Built-In Test Equipment
- No Deep Cycling
- No "Memory" Characteristics
- Inexpensive Battery Replacement
- Full 3 Year Warranty on Batteries
- Full 5 Year Warranty on Electronics
- **No Need to Remove for Capacity Check**

Applications

- IRS/INS/3rd Standby Attitude Reference System Back-up Power
- Emergency Lighting

Batteries

Sealed Lead Acid Hawker "Cyclon" Batteries (Dry Cells); 18-24 VDC Output at 3.5 amps for 30 minutes* or 5 amps for 20 minutes.

* Discharge rates for new batteries only.

Built-in Battery Charger

Precision charges battery from aircraft 28 VDC power bus to ensure that the batteries are always maintained at full capacity while minimizing temperature fatigue cycles. Operates in bulk, topping, and trickle modes. Battery will reach 80-90% energy capacity in less than one hour. Contains overheat protection, charge monitoring (at unit front panel), and overload protection.

Battery Test

Battery test function places a known load on the battery and measures battery voltage. The front panel LEDs indicate "Battery Low" at energy levels at or below 65%, and "Battery OK" above 65%. **No need to remove from aircraft to perform capacity check**

No need to remove from aircraft for capacity test



Information is subject to change. Please contact Securaplane for current information.



Emergency Battery System

XL243B

Physical Characteristics

Size: 6.30 inches long, 5.60 inches wide (plus 0.85 inch mounting flange on each side), 2.80 inches high.

Connector: MS3126E14-5PW

Qual: (DO160C) 4(F2), 5(B), 6(B), 7, 8(C), 16(Z), 17(A), 20(R), 21(Z), 22(A3C3)

Weight: 7.0 lbs. max.

Transportation: Dry cell classification by DOT.

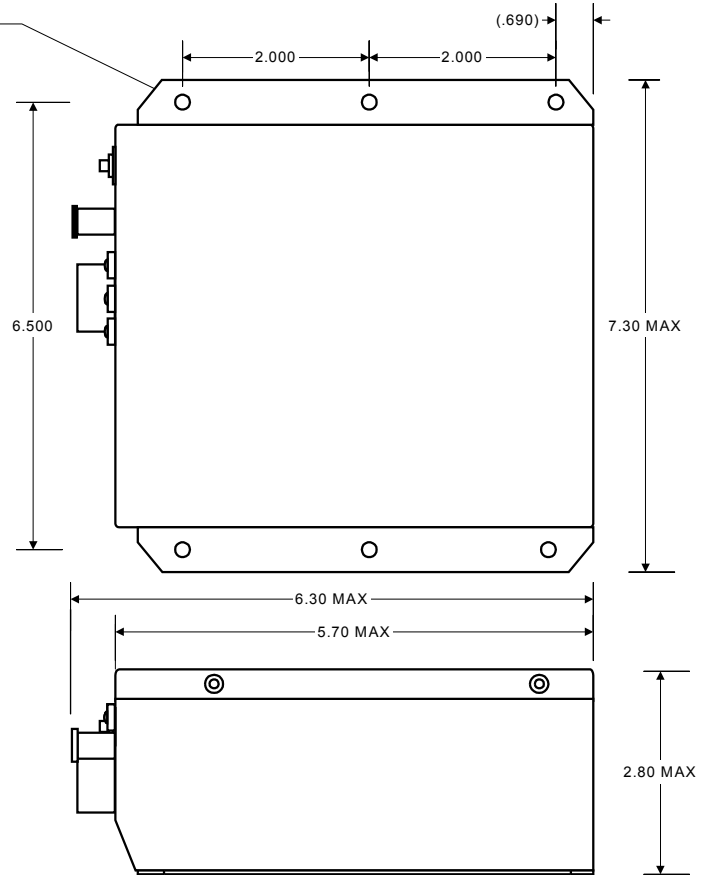
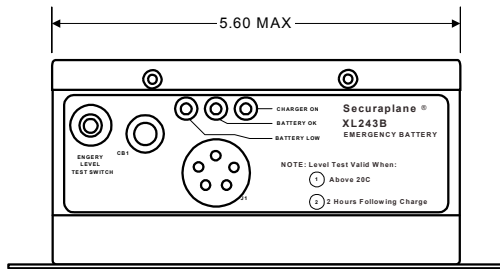

NOTE: DIMENSIONS IN () ARE FOR REFERENCE ONLY.

Functional Characteristics

Input Power: 25-32VDC (28VDC nominal)
5.5A Maximum (No output load)

Output Power: Battery output 18-24VDC
15A Maximum
(2.4A for 45 minutes)

XL243B Battery Discharge Rate

1.7 and 2.4 Amperes discharge rates.

