

Solid State Relays

High Reliability

Vdc Input/Vac Output,
Vac Input/Vac Output

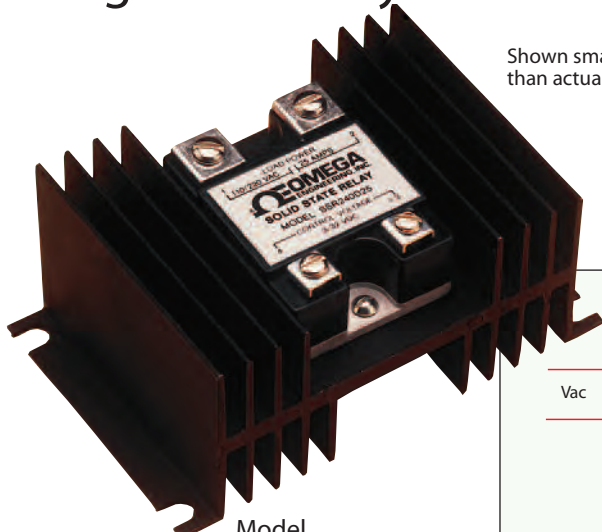

Shown smaller
than actual size

Model
SSR240DC25

Shown with FHS-1

- ✓ Current Ratings to 90 Amps
- ✓ Multi-Million Cycle Life
- ✓ Compatible with Temperature Controllers
- ✓ Solid-State, SCR Design
- ✓ Zero Voltage Switching
- ✓ Control ac Lines to 440 Vac
- ✓ ac and dc Control Signal Models
- ✓ 200% Testing at Rated Current

These SSR's control resistance heaters up to 10 kW using solid state relays in conjunction with lower rated temperature controllers. Solid state relays are SPST, normally open switching devices with no moving parts, capable of millions of cycles of operation. By applying a control signal, an SSR switches "ON" the ac load current, just as the moving contacts do on a mechanical contactor. Three-phase loads can be controlled using 2 or 3 SSR's. Use 3 SSR's for "Y" or "star" 3-phase loads using a neutral line. Two SSR's will control "delta" loads with no neutral line. Three solid state relays are also used when there is no neutral load to provide redundancy and extra assurance of control.

"Switching" takes place at the zero voltage crossover point of the alternating current cycle. Because of this, no appreciable electrical noise is generated, making SSR's ideal for environments where there are apparatuses susceptible to RFI.

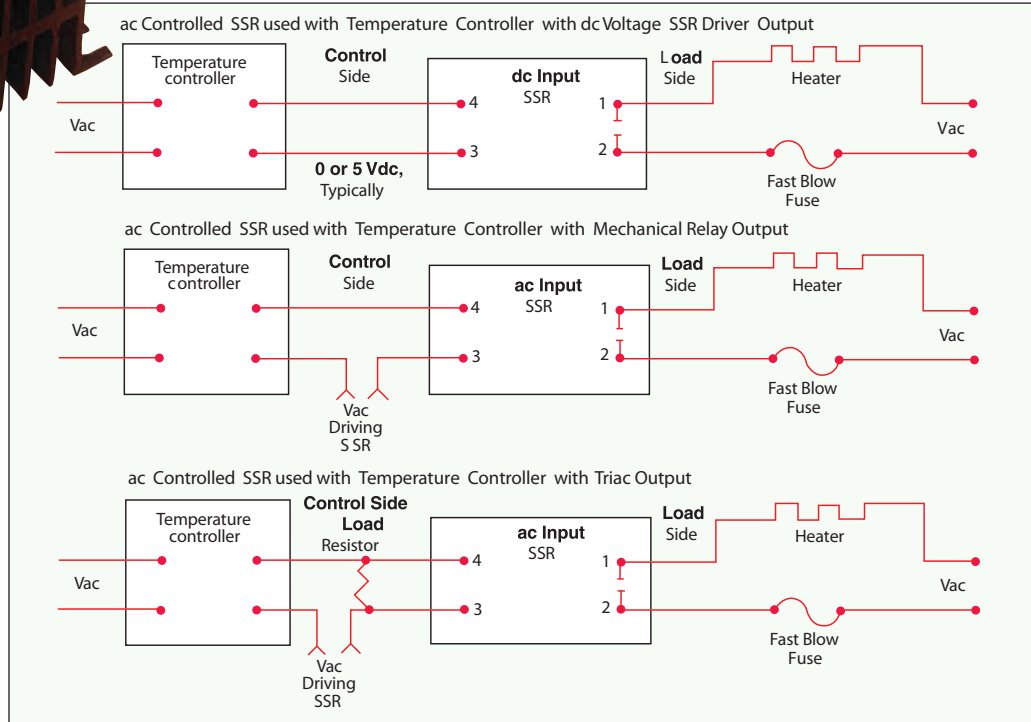

Typical Applications

Common Specifications

Operating Temperature:

-20 to 80°C (-5 to 175°F)

Storage Temperature:

-40 to 80°C (-40 to 175°F)

Isolation: 4000 Vrms, input to output;

2500 Vrms input/output to ground

Capacitance: 8 pF, input to output (max)

Line Frequency Range: 47 to 63 Hz

Turn-On Time: 20 ms, ac; 05 cycle, dc

Turn-Off Time: 30 ms, ac; 05 cycle, dc

Output Specifications for Vac and Vdc Input Models

Specifications	10 Amp	25 Amp	45 Amp	50 Amp	75 Amp	90 Amp
Max On State Current	10 A	25 A	45 A	50 A	75 A	90 A
Min On State Current	100 mA					
Max 1-Cycle Surge	100 A	250 A	450 A	500 A	700 A	1000 A
Max 1 sec Surge	30 A	75 A	135 A	145 A	200 A	280 A
1 ^T (60 Hz), A ² sec	200	260	840	1040	2345	3375

Solid State Relays



These SSR's are of the twin SCR type, inherently more reliable and capable of higher overloads before failure than triacs. Heat is developed in a solid state relay due to the nominal voltage drop across the switching device. To dissipate the heat, an SSR must be mounted on a finned heat sink or aluminum plate. An SSR should be located where the ambient temperature is relatively low, since the current switching rating is lowered as the temperature increases. Another SSR characteristic is a small leakage current across the output when the relay is open. Because of this, a voltage will always exist on the load side of the device.

In comparing SSR's with mechanical contactors, the SSR has a cycle life many times that of a comparably priced contactor. However, SSR's are more prone to failure due to overload and improper initial wiring. Solid state relays can fail, contact closed, on overload circuits.

Finned heat sinks are anodized fabrications that come complete with tapped mounting holes and screws. See thermal rating curves and ordering instructions for proper selection.

SSR baseplate to heat sink thermal resistance is affected by use of a thermally conducting compound. OMEGATHERM[®] OT-201 placed between the heat sink and SSR baseplate will significantly improve the thermal conductivity. It is also suggested that 10-inch-pounds of torque be used on the SSR mounting screws.

FHS Heat Sink Dimensions and Specifications

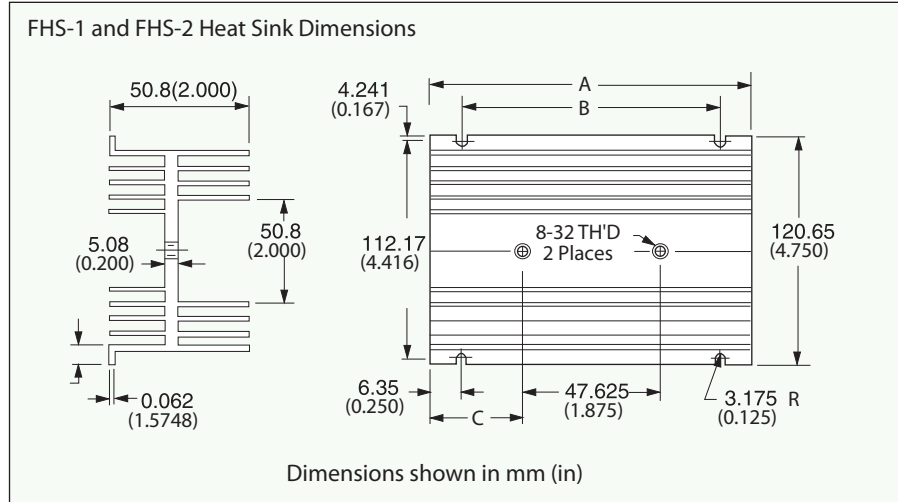

Model No.	A	B	C	Thermal Rating
FHS-1	3.00"	2.50"	0.56"	2 °C/W
FHS-2	5.50"	5.00"	1.81"	1.2 °C/W

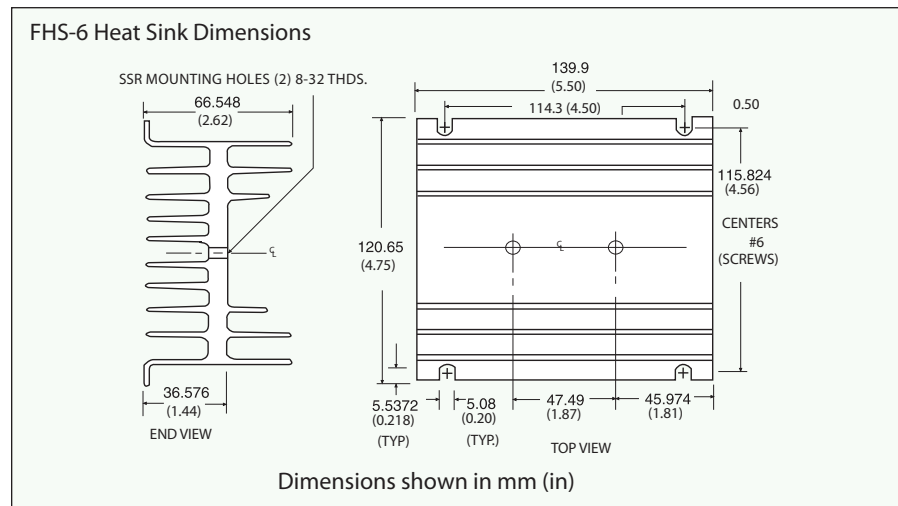

SSR240 Series Electrical Specifications

Model No.	Type	Control Signal Voltage	Input-Control Signal			Input & Output
			Control Signal Turn-On	Control Signal Turn-Off	Signal Input Impedance	Peak Repetitive Voltage Min.
SSR240AC10 SSR240AC25 SSR240AC45 SSR240AC75 SSR240AC90	ac Control Signal	90 to 280 Vac	90 Vac	10 Vac	40 k	500 V
SSR240DC10 SSR240DC25 SSR240DC45 SSR240DC75 SSR240DC90	dc Control Signal	3 to 32 Vdc	3 Vdc	1 Vdc	1 k	500 V
SSR440AC50 SSR440AC75 SSR440AC90	ac Control Signal	90 to 280 Vac	90 Vac	10 Vac	40 k	1200 V
SSR440DC50 SSR440DC75 SSR440DC90	dc Control Signal	3 to 32 Vdc	3 Vdc	1 Vdc	1 k	1200 V

Derate current 20% for horizontal fin mount.
Derate current 50% for 220 Vac

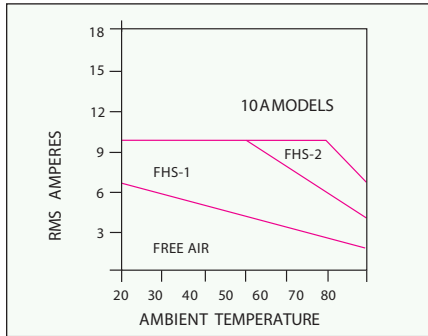

Derate current 20% for horizontal fin mount.
Derate current 50% for 220 Vac

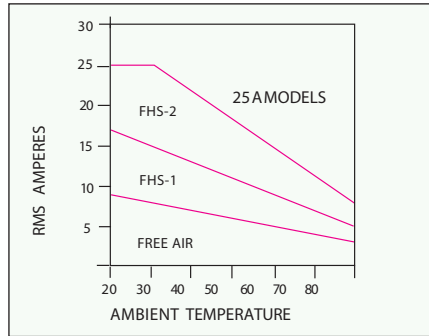

Derate current 20% for horizontal fin mount.
Derate current 50% for 220 Vac

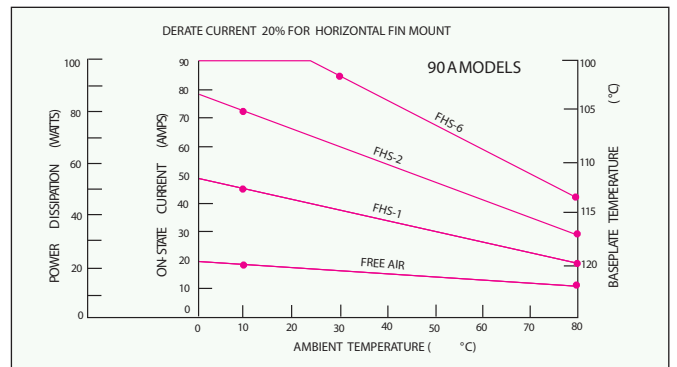
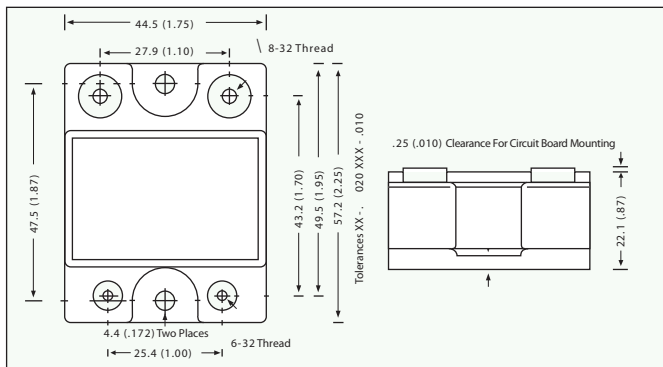
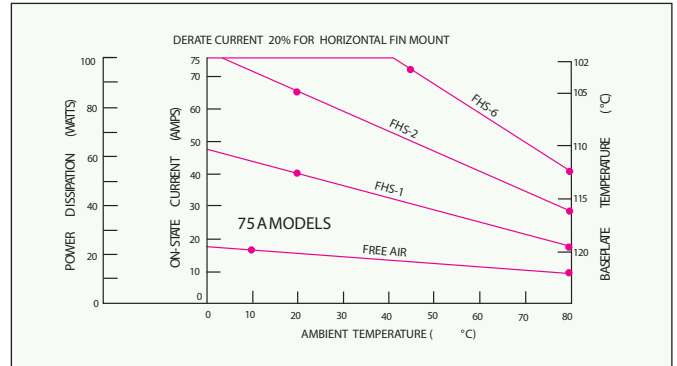
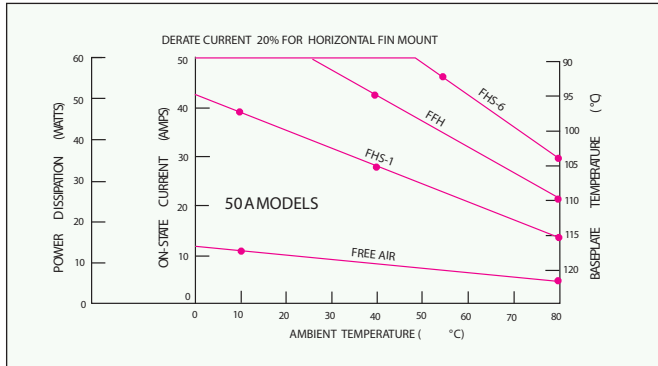
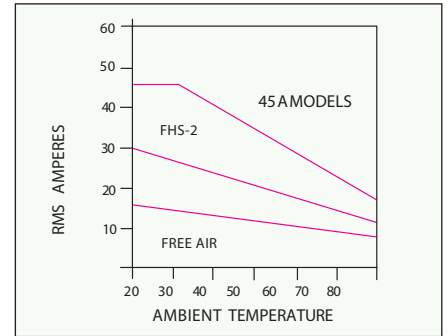

SSR240 Series Output-Vac Load Specifications

Model No.	Nominal ac Line Voltage	Nominal Load Current	Max. Contact Voltage Drop	Max. Off-State Leakage (25°C max. ambient)			Dissipation Watt/Amps
				120 Vac	240 Vac	440 Vac	
SSR240AC10	24 to 280 Vac	10 A	1.6 V	7.5 mA	15 mA	N/A	1.6
SSR240AC25		25 A		7.5 mA	15 mA		1.3
SSR240AC45		45 A		7.5 mA	15 mA		0.9
SSR240AC75		75 A		7.5 mA	15 mA		*
SSR240AC90		90 A		7.5 mA	15 mA		*
SSR240DC10	24 to 280 Vac	10 A	1.6 V	7.5 mA	15 mA	N/A	1.6
SSR240DC25		25 A		7.5 mA	15 mA		1.3
SSR240DC45		45 A		7.5 mA	15 mA		0.9
SSR240DC75		75 A		7.5 mA	15 mA		*
SSR240DC90		90 A		7.5 mA	15 mA		*
SSR440AC50	36 to 480 Vac	50 A	1.6 V	4 mA	8 mA	15 mA	*
SSR440AC75		75 A		4 mA	8 mA	15 mA	*
SSR440AC90		90 A		4 mA	8 mA	15 mA	*
SSR440DC50	36 to 480 Vac	50 A	1.6 V	4 mA	8 mA	15 mA	*
SSR440DC75		75 A		4 mA	8 mA	15 mA	*
SSR440DC90		90 A		4 mA	8 mA	15 mA	*

Transients of 1 min. max duration above table value should be suppressed.

*For base plate temperature and max. power dissipation, see figures above.

Solid State Relays

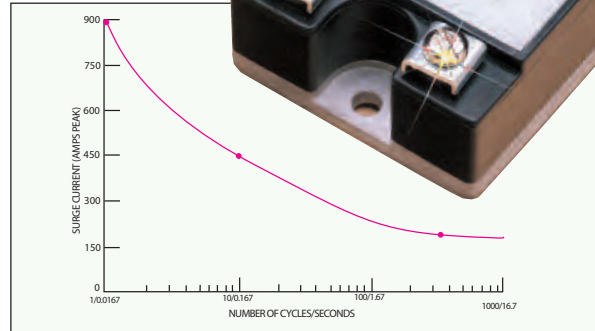
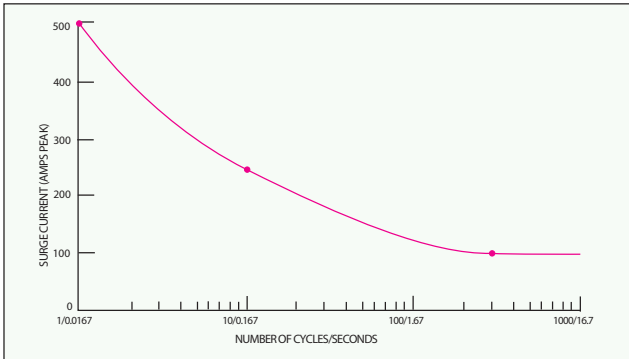
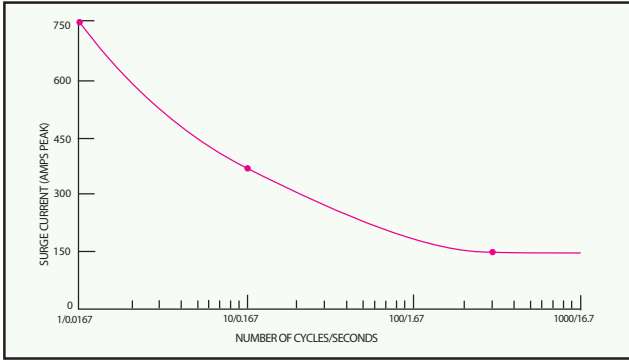

Thermally Conductive Compound for Use Between Heat Sink and SSR

Model No.	e	Description
OT-201-1/2		14 g (1/2 oz) size
OT-201-2		57 g (2 oz) size
OT-201-16		454 g (1 lb) size

IN STOCK FOR FAST DELIVERY!

To Order (Specify Model Number)			
Model No.	e	Description	Nominal Rating
SSR240AC10		ac Control Signal (280 Vac line)	10 A
SSR240AC25			25 A
SSR240AC45			45 A
SSR240AC75			75 A
SSR240AC90			90 A
SSR240DC10		dc Control Signal (280 Vac line)	10 A
SSR240DC25			25 A
SSR240DC45			45 A
SSR240DC75			75 A
SSR240DC90			90 A
SSR440AC50		ac Control Signal (440 Vac line)	50 A
SSR440AC75			75 A
SSR440AC90			90 A
SSR440DC50		dc Control Signal (440 Vac line)	45 A
SSR440DC75			75 A
SSR440DC90			90 A
FHS-1		Finned Heat Sink	2°C/W
FHS-2			1.2°C/W
FHS-6			0.7°C/W

Fuses

To Order (Specify Model No.)		
Model No.	e	Capacity
KAX-10		10 A
KAX-25		25 A
KAX-30		30 A
KAX-45		45 A
KAX-70		70 A
KAX-90		90 A
KBH-50		50 A
KBH-70		70 A
KBH-90B		90 A

Fuse Blocks

To Order (Specify Model No.)		
Model No.	e	Compatible Fuses
FB-1		KAX-10, KAX-25, KAX-30
FB-2		KAX-10, KAX-25, KAX-30
FB-3		KAX-10, KAX-25, KAX-30
BS-101		KAX-45, KAX-75, KAX-90, KBH (all models)

Shunt Resistors

To Order (Specify Model No.)		
Model No.	e	Value
SSRR20-12		2000 ohms, 12 watts
SSRR20-50		2000 ohms, 150 watts
SSRR15-12		1500 ohms, 12 watts
SSRR15-50		1500 ohms, 50 watts

Shunt Resistor Guide for Controllers with Triac or SSR Outputs

Controller Model No.	Model No. Resistor 120 Vac	Model No. Resistor 240 Vac
CN2000, CN2010, CN2040	SSRR20-12	5 SSRR20- 0
CN9131A, CN9231, or CN9231A	SSRR12-12	SSRR15-50

For Additional Controllers and Indicators, See Section M

