

WebView-1070H

10.4" Web-enabled HMI



Features

- Compact design with Die-Casting
- Fanless cooling system
- NEMA4/IP65 compliant front panel
- Supports Microsoft® Windows® XP/2000/CE and WinXPe
- Downward I/O cabling
- Automatic data flow control RS-485
- Dual fast Ethernet supported
- Built-in Windows® CE with Advantech WinCE WebAccess
- Supports Vector-based graphics
- Remote control and monitor by Ordinary IE Browser
- Supports calendar scheduler
- Import BMP, JPEG, GIF, ACAD DXF



Introduction

Advantech's WebView-1070H is a web-based human-machine interface (HMI) and supervisory control and data acquisition (SCADA) platform. All the features are available in an ordinary web browser including Animated Graphics Displays, Real-time Data, Controllers, Trends, Alarms and Logs, Scheduler, Recipes, and more.

Specifications

General

- **BIOS** Award® 4 MB
- **Certifications** BSMI, CCC, CE, FCC, UL
- **Cooling System** Fanless design
- **Dimensions (W x H x D)** 286 x 226 x 58 mm (11.26" x 8.9" x 2.28")
- **Enclosure** Die-Casting Aluminum alloy
- **Mounting** Desktop, Wall or Panel Mount
- **OS Support** Windows XP/2000/CE and WinXPe
- **Power Consumption** 60 W
- **Power Input** 18 ~ 32 V_{DC}
- **Watchdog Timer** 1 sec (system)
- **Weight (Net)** 3.5 kg (7.72 lbs)

System Hardware

- **CPU** Intel Pentium M 1.4 GHz/Celeron M 1 GHz
- **Expansion Slots** 1 x CompactFlash slot
1 x PCI-104 slot
- **Graphics Controller** Intel 855 GME
- **Keyboard/Mouse Ports** 1 x PS/2
- **LAN** 1 x 10/100Base-T, 1 x 10/100/1000Base-T
- **Memory** 512 MB DDR SDRAM
- **Serial Ports** 2 x RS-232 and 1 x RS-232/485/422
- **Storage** 1 x CompactFlash card (optional), or
1 x 2.5" HDD (optional)
- **USB Ports** 2 x USB 2.0

Environment

- **Humidity** 10 ~ 95% RH @ 40° C, non-condensing
- **Ingress Protection** Front panel: NEMA4, IP65
- **Operating Temperature** 0 ~ 50° C (32 ~ 122° F)
- **Storage Temperature** -20 ~ 70° C (-4 ~ 158° F)
- **Vibration Protection** With CompactFlash: 2 grms (5 ~ 500 Hz)
With HDD: 1 grms

LCD Display

- **Backlight Life** 50,000
- **Contrast Ratio** 500:1
- **Display Size** 10.4"
- **Display Type** SVGA TFT LCD
- **Luminance cd/m2** 400
- **Max. Colors** 260 K
- **Max. Resolution** 800 x 600
- **Viewing Angle (H/V)** 140/110

Touchscreen

- **Lifespan** 1 million touches at single point
- **Light Transmission** Above 75%
- **Pixel Pitch (H x V)** 0.3075 x 0.3075 mm
- **Resolution** 1024 x 1024
- **Type** 8-wire, analog resistive

Software Specifications

- **Operating System** Windows CE

Advantech WinCE WebAccess specifications:

- **I/O Tag Number** 150/600
- **Internal Tag Number** 150/600
- **Web Client** 2
- **Alarm Logging** 1000
- **Action Logging** 1000
- **Message Characters** 50

Graphics

- **# of Graphic Pages** 100
- **Macro Key** Yes Local
- **Script** Yes Variable
- **Per Graphic Page** 255

Dimensions

Unit: mm

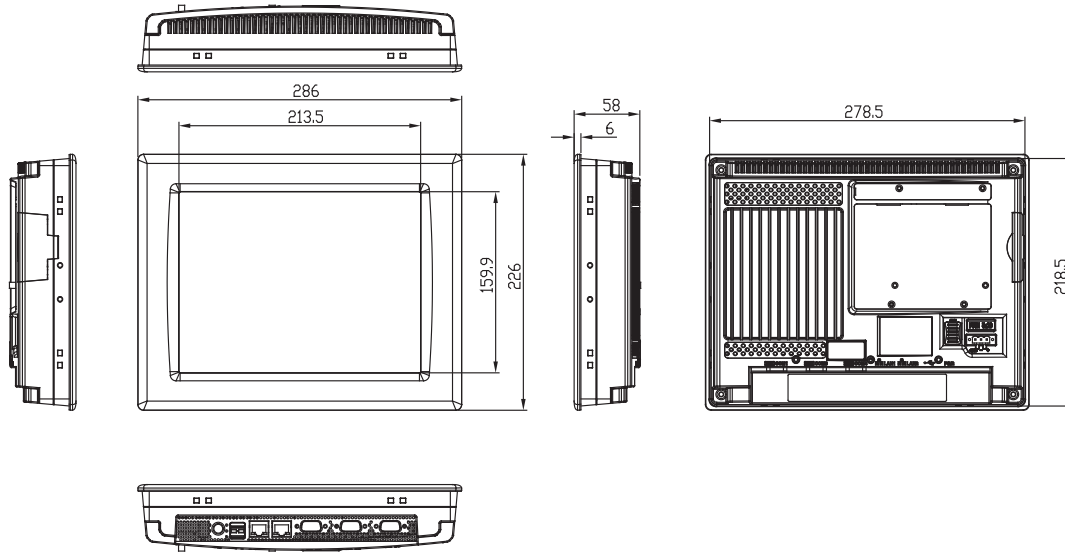

Panel Cut-out Dimensions: 279.5 x 219.5 mm

WebAccess Specifications (cont.)

Data Trend Log

- # of data logging 50 Tags

Recipe

- Recipes per Project 100
- Unit per Recipe 100
- Item per Unit 999

Scheduler

- Holiday Configuration 10 groups
- Time Zone Group 99
- Device Loop Group 99
- Equipment Group 99

Ordering Information

- WView1070-150-C50E** 10.4" Web-enable HMI with 150 tags
- WView1070-600-C50E** 10.4" Web-enable HMI with 600 tags

Rear View

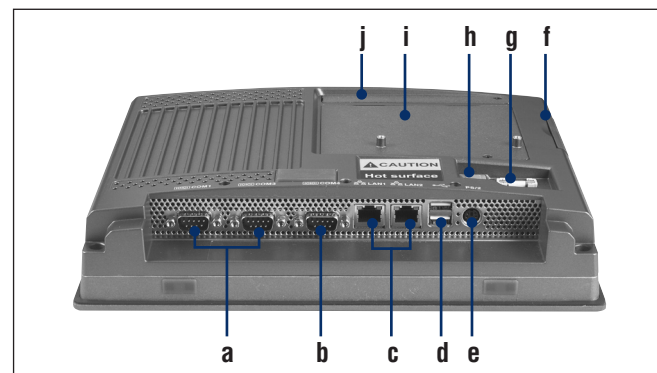

- a. COM (RS-232)
- b. COM (RS-232/422/485)
- c. LAN (10/100,1G)
- d. USB 2.0
- e. PS/2
- f. CompactFlash
- g. Fuse (3.15A)
- h. Power Switch, Power Receptor
- i. HDD Cover
- j. PCI-104