

DSP230

Quad Freescale MPC864xx Multi Fabric 6U VPX Multiprocessor

Features

- Four Freescale 8640D SoC nodes
- Eight banks DDR2 SDRAM
- Eight port Serial RapidIO switch
- Forty-eight lane gen_2 PCIe switch
- One PMC-X / XMC (VITA 42.3) site
- Gigabit Ethernet switch with VLAN
- Central communications resource FPGA
- Eight serial ports
- Rugged 6U VITA 46 & VITA 48/REDI builds

Software

- AXIS Advanced Multiprocessor Integrated Software
- Built-In-Test (BIT) for PowerPC®
- BSPs for LynxOS® 5.0 & VxWorks® 6.6
- Linux Software Development Kit

DSP230 sets the standard for COTS multi-processors aimed at rugged defense and aerospace applications such as deployed radar, sonar, signal intelligence and image processing.

Available in air, spray and conduction cooled builds, the DSP230 quad 8640D 6U VPX multiprocessor supports concurrent, any node to any node, data over PCIe, Serial RapidIO and Gigabit Ethernet via onboard switched fabrics. The onboard gen_2 PCIe switch supports high speed data to all four 8640D nodes, the PMC/XMC and optional P2 connector. Two additional ports to the system back plane can be enabled via the XMCPN526 expansion board.

DSP230 is designed for use with our GE SBC610 MPC864xx single board computer, PEX44x dual slot PMC/XMC carriers and XMCV5, Xilinx Virtex-5 mezzanine coprocessor providing maximum flexibility to system architects.

AXIS Advanced Multiprocessor Integrated Software provides a suite of fully integrated modules for system development, visualization and deployment including example applications such as a distributed corner turn and stress tests providing a quick start for application development and system evaluation.

RuntimeView shows an AXIS Quick Start example application to assist with algorithm development and system characterization.

System integrators can benchmark their application to scope performance, size, weight and power (SwaP) requirements for the deployed platform.

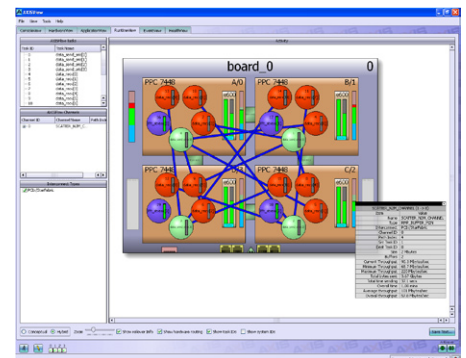

AXISLib VSIPL and RSPL optimized DSP, math and function libraries provide a wide range of optimized functions for the PowerPC e600 / AltiVec platform.

AXISFlow supports high through put, low latency, interprocessor communication (IPC) across all system nodes to maximize system performance, and increase flexibility in the design of the most demanding signal and data processing applications.



DSP230 Quad Freescale MPC864xx Multi Fabric 6U VPX Multiprocessor

Specifications

Form Factor

- 6U VITA 46 or VITA 48/REDI

Processors

- Four MPC8640D dual core processors
- Single core mode is also supported

Memory

- Eight banks DDR2 SDRAM
 - 512 MBytes per bank (standard)
- Two banks of 256 MBytes FLASH

Multi Fabric Architecture

- Serial RapidIO switch
 - Four x4 ports to P1
 - One x4 port to each 864xx
 - Up to 3.125 GHz operation per lane
 - Full featured sRIO driver with dynamic device discovery, and enumeration, broadcast and multi-cast support
- PCIe switch
 - One x8 port to each 8640D node
 - One x8 port to XMC site
 - One x4 port bridged to PCI-X PMC
 - One x4 port to optional P2 connector
- Gigabit Ethernet Switch
 - Two ports to each 864xx
 - One or two ports to backplane
 - One port to Front Panel (air cooled builds only)

Central Communication Resource FPGA

- Inter-node and inter-board
 - Time stamp, synchronization
 - Mail boxes, semaphores

Serial

- 8 ports to P2 connector
 - Four RS232 to front panel (air cooled builds only)
 - Four RS232 or RS422

Ruggedization

- Build levels 1 to 6
- Optional VITA 48/REDI 2LM build

Software

- BIT for PowerPC®
- BSPs for LynxOS 5.0 & VxWorks 6.x with advanced sRIO driver support
- AXIS Advanced Multiprocessor Integrated Software
- Linux Software Development Kit
- AXIS Quick Start Example Applications

Block Diagram

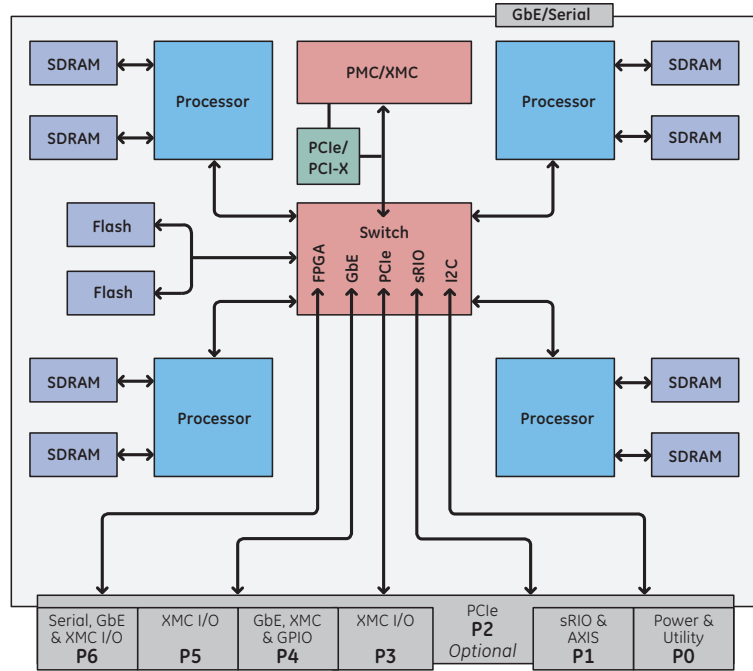

Ordering Information

DSP230-1 0 4 4 4 3 = standard build

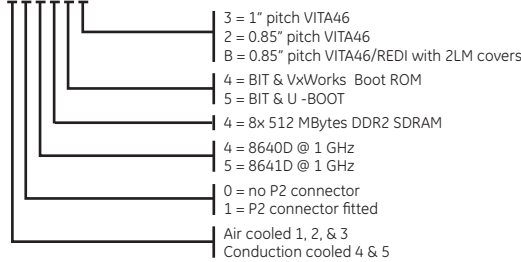

AXIS Multicomputer

Open Architecture, COTS Multiprocessor Solutions

Customer Application
AXIS Advanced Multiprocessor Integrated Software
Universal Interface Layer (UIL)
Board Support Package (BSP)
Built-in-Test (Configurable POST)
I/O, SBCs, Multiprocessors, Fabric Switches

About GE Intelligent Platforms

GE Intelligent Platforms, a General Electric Company (NYSE: GE), is an experienced high-performance technology company and a global provider of hardware, software, services, and expertise in automation and embedded computing. We offer a unique foundation of agile, advanced and ultra-reliable technology that provides customers a sustainable advantage in the industries they serve, including energy, water, consumer packaged goods, government and defense, and telecommunications. GE Intelligent Platforms is a worldwide company headquartered in Charlottesville, VA and is part of GE Enterprise Solutions. For more information, visit www.ge-ip.com.

GE Intelligent Platforms Contact Information

Americas: 1 800 433 2682 or 1 434 978 5100.

Global regional phone numbers are listed by location on our web site at www.ge-ip.com/contact.

www.ge-ip.com

